

# ОСНОВНЫЕ ОРТОГОНАЛЬНЫЕ ФУНКЦИИ И ИХ ПРИЛОЖЕНИЯ

ЧАСТЬ I. ОРТОГОНАЛЬНЫЕ ФУНКЦИИ ЭКСПОНЕНЦИАЛЬНОГО ТИПА

УДК 517.587:519.216

Прохоров С.А., Куликовских И.М. Основные ортогональные функции и их приложения. Часть I. Ортогональные функции экспоненциального типа. – Самара: Издательство Самарского научного центра РАН, 2013. – 200 с.

ISBN 978-5-93424-652-6

В первой части предлагаемой монографии рассматриваются ортогональные функции экспоненциального типа.

Структура монографии разработана с учетом дальнейшего приложения к построению математических моделей через разложение в ряды Фурье и охватывает следующие вопросы: аналитические, фазовые, интегральные представления, основные и расширенные свойства во временной и частотной областях, рекуррентные соотношения, соотношения взаимосвязи базисных функций, обобщенные характеристики ортогональных функций.

Печатается по решению издательского совета Самарского научного центра РАН

ISBN 978-5-93424-652-6

© Прохоров С.А., 2013

© Куликовских И.М., 2013

# Предисловие

Вашему вниманию предлагается первая часть монографии по основным ортогональным функциям и их приложениям. Эта работа по-своему уникальна, потому как ориентирована, в первую очередь, на конкретного читателя - прикладного математика и программиста - для создания адекватных моделей, оптимальных алгоритмов и написания исходного кода с минимальными вычислительными и ресурсными затратами при решении частных задач. Тем не менее математический аппарат, положенный в основу работы, - теория ортогональных многочленов и рядов Фурье - имеет большой теоретический интерес. Поэтому авторы надеются, что данная работа будет интересна более широкой аудитории.

Под основными ортогональными функциями экспоненциального типа, отраженными в названии работы, на данном этапе, понимаются классические обобщенные многочлены Лагерра  $L_k^{(\alpha)}(\tau, \gamma)$ , многочлены Якоби  $P_k^{(\alpha, \beta)}(\tau, \gamma)$ , заданные на интервале  $\tau \in [0, \infty)$  с использованием соответствующей замены экспоненциального типа и введением варьируемого параметра масштаба  $\gamma$ . Математическим аспектам определения функций экспоненциального типа и их свойствам значительно больше внимания уделено в тексте монографии в соответствующих разделах. Главным образом ортогональные функции экспоненциального типа предназначены для приближения функций  $f(\tau)$ , заданной на положительной полуоси  $\tau \in [0, \infty)$ , для которой справедливо

$$\arg(\max(f(\tau))) = 0; \lim_{\tau \rightarrow \infty} f(\tau) \rightarrow 0; \int_0^{\infty} (f(\tau))^2 \mu(\tau, \gamma) d\tau < \infty.$$

Вопросы, касающиеся построения моделей  $f(\tau)$  и их разложения в ряды Фурье, а также разработки соответствующих алгоритмов оптимизации при решении задач приближения, будут рассмотрены в последующих главах.

Структура предлагаемой части монографии разработана с учетом дальнейшего приложения к построению математических моделей через разложение в ряды Фурье. В целом первая часть работы охватывает следующие вопросы:

- аналитическое представление во временной области;
- основные и расширенные свойства во временной области;
- основные и расширенные соотношения ортогональности во временной области;
- фазовое представление ортогональных функций;
- интегральное представление ортогональных функций;
- аналитическое представление в частотной области;

- основные и расширенные свойства в частотной области;
- основные и расширенные соотношения ортогональности в частотной области;
- рекуррентные соотношения;
- соотношения взаимосвязи базисных функций;
- обобщенные характеристики ортогональных функций;
- соотношения неопределенности.

Каждый из приведенных разделов содержит следующие этапы:

- определение;
- последовательность нумерованных формул:
  - частные случаи 0-5 порядков;
  - графическая интерпретация частных случаев при заданных параметрах.

На сегодняшний день насчитывается большое число справочников, посвященных описанию специальных функций и ортогональных многочленов. Среди наиболее распространенных следующие: I.S. Gradshteyn, I.M. Ryzhik «Table of Integrals, Series, and Products» (2007); Y.A. Brychkov «Handbook of Special Functions: Derivatives, Integrals, Series and Other Formulas» (2008); NIST Handbook of mathematical functions (2010); М. Абрамовиц, И. Стиган «Справочник по специальным функциям» (1979); А.П. Прудников, Ю.А. Брычков, О.И. Маричев «Интегралы и ряды» (т. 2,3) (1983).

В свою очередь авторы хотели бы обратить внимание в предлагаемой монографии на класс анализируемых функций и на специфику конечных формул, что несомненно определяет их новизну. Более того, в рамках данной работы введен ряд новых понятий и определений, которые имеют значительный практический интерес и расширяют теорию ортогональных многочленов в целом.

На данный момент неоднократно проводилась апробация предлагаемых в монографии формул для построения математических моделей как для создания масштабных проектов - систем «Data Mining», где требуется одновременная обработка больших потоков данных, так и для создания актуальных на данном этапе развития информационных технологий - мобильных приложений на базе таких платформ как iOS, Android, и т.д., основными требованиями которых являются сниженные ресурсные затраты, высокая скорость выполнения операций и низкие требования к объему используемой памяти.

Структура монографии, способ представления материала, фактический материал и графические интерпретации являются исключительно авторскими.

Авторы выражают большую признательность к.ф.-м.н. Л.П. Усольцеву за ценные замечания и внимательное отношение к работе на различных этапах ее формирования.

С.А. Прохоров  
И.М. Куликовских

# Содержание

Предисловие	3
<b>I ОРТОГОНАЛЬНЫЕ ФУНКЦИИ ЭКСПОНЕНЦИАЛЬНОГО ТИПА</b>	<b>7</b>
<b>1 Аналитические представления во временной области</b>	<b>9</b>
1.1 Аналитические соотношения для ортогональных функций . . . . .	10
1.2 Аналитические соотношения для производных ортогональных функций . .	15
1.3 Аналитические соотношения для неопределенных интегралов от ортогональных функций . . . . .	41
<b>2 Основные и расширенные свойства во временной области</b>	<b>83</b>
<b>3 Основные и расширенные соотношения ортогональности во временной области</b>	<b>85</b>
3.1 Основные соотношения ортогональности . . . . .	85
3.2 Расширенные соотношения ортогональности . . . . .	90
<b>4 Фазовые представления ортогональных функций</b>	<b>105</b>
<b>5 Интегральные представления ортогональных функций</b>	<b>111</b>
<b>6 Аналитические представления в частотной области</b>	<b>115</b>
6.1 Преобразование Фурье ортогональных функций . . . . .	115
6.2 Преобразование Фурье ортогональных фильтров . . . . .	123
6.3 Преобразование Фурье производных ортогональных функций . . . . .	131
6.4 Производные преобразований Фурье ортогональных функций . . . . .	140
6.5 Производные преобразований Фурье ортогональных фильтров . . . . .	150
<b>7 Основные и расширенные свойства в частотной области</b>	<b>163</b>

<b>8</b>	<b>Основные и расширенные соотношения ортогональности в частотной области</b>	<b>165</b>
8.1	Основные соотношения ортогональности . . . . .	165
8.2	Расширенные соотношения ортогональности . . . . .	169
<b>9</b>	<b>Рекуррентные соотношения</b>	<b>175</b>
9.1	Рекуррентные соотношения для ортогональных функций . . . . .	175
9.2	Рекуррентные соотношения для производных ортогональных функций . . . . .	176
9.3	Рекуррентные соотношения для неопределенных интегралов от ортогональных функций . . . . .	177
9.4	Рекуррентные соотношения для преобразований Фурье . . . . .	179
<b>10</b>	<b>Соотношения взаимосвязи базисных функций</b>	<b>181</b>
10.1	Соотношения взаимосвязи ортогональных функций . . . . .	181
10.2	Соотношения взаимосвязи ортогональных функций и производных ортогональных функций . . . . .	182
10.3	Соотношения взаимосвязи ортогональных функций и неопределенных интегралов от ортогональных функций . . . . .	183
10.4	Соотношения взаимосвязи преобразований Фурье . . . . .	183
<b>11</b>	<b>Обобщенные характеристики ортогональных функций</b>	<b>185</b>
11.1	Длительности ортогональных функций во временной области . . . . .	186
11.2	Моментные характеристики ортогональных функций во временной области . . . . .	186
11.3	Длительности ортогональных функций в частотной области . . . . .	189
11.4	Моментные характеристики ортогональных функций в частотной области . . . . .	190
<b>12</b>	<b>Соотношения неопределенности</b>	<b>195</b>
	<b>Список использованных источников</b>	<b>195</b>

Часть I

**ОРТОГОНАЛЬНЫЕ ФУНКЦИИ  
ЭКСПОНЕНЦИАЛЬНОГО ТИПА**





## Глава 1

# Аналитические представления во временной области

### Определение.

Классические ортогональные многочлены  $\psi_k(x)$  являются решением дифференциального уравнения [2, 4, 13, 18]

$$(ax^2 + bx + c)\psi_k''(x) + (dx + e)\psi_k'(x) - k(d + (k - 1)a)\psi_k(x) = 0$$

и при заданных параметрах данного уравнения имеем три основных класса многочленов: Якоби, обобщенные Лагерра и Эрмита. Остановимся на рассмотрении ортогональных многочленов Якоби  $P_k^{(\alpha, \beta)}(x)$  и обобщенных многочленов Лагерра  $L_k^{(\alpha)}(x)$  [2, 4, 13, 16, 17, 19].

Если  $a = -1$ ,  $b = 0$ ,  $c = 1$ ,  $d = -\alpha - \beta - 2$  и  $e = -\alpha + \beta$ , и имеем ортогональные многочлены Якоби [13, 16]

$$P_k^{(\alpha, \beta)}(x) = \frac{(-1)^k}{k!2^k} (1-x)^{-\alpha} (1+x)^{-\beta} \frac{d^k((1-x)^{\alpha+k} (1+x)^{\beta+k})}{dx^k}$$

с весовой функцией  $\mu^{\{P_k^{(\alpha, \beta)}(x)\}}(x) = (1-x)^\alpha (1+x)^\beta$ , удовлетворяющие условию

$$\int_{-1}^1 P_k^{(\alpha, \beta)}(x) P_n^{(\alpha, \beta)}(x) \mu^{\{P_k^{(\alpha, \beta)}(x)\}}(x) dx = \frac{2^{\alpha+\beta+1} \Gamma(\alpha+k+1) \Gamma(\beta+k+1)}{k! (\alpha+\beta+2k+1) \Gamma(\alpha+\beta+k+1)} \delta_{k,n},$$

где  $\delta_{k,n}$  – символ Кронекера. При  $k = n$  последнее соотношение имеет вид  $\|P_k^{(\alpha, \beta)}\|^2$  и называется нормой ортогональных функций Якоби.

Если  $a = 0$ ,  $b = 1$ ,  $c = 0$ ,  $d = -1$  и  $e = \alpha + 1$ , имеем обобщенные ортогональные многочлены Лагерра [13, 16]

$$L_k^{(\alpha)}(x) = (-1)^k x^{-\alpha} e^x \frac{d^k (x^{\alpha+k} e^{-x})}{dx^k}$$

с весовой функцией  $\mu^{\{L_k^{(\alpha)}(x)\}}(x) = x^\alpha e^{-x}$ , удовлетворяющие условию

$$\int_0^\infty L_k^{(\alpha)}(x) L_n^{(\alpha)}(x) \mu^{\{L_k^{(\alpha)}(x)\}}(x) dx = k! \Gamma(\alpha+k+1) \delta_{k,n}.$$

При  $k = n$  вышеприведенное соотношение обозначается  $\|L_k^{(\alpha)}\|^2$  и называется нормой обобщенных ортогональных функций Лагерра.

В последующем ортогональные многочлены  $\psi_k(x)$ , заданные на интервале  $[0, \infty)$  с использованием замены экспоненциального типа, определим как ортогональные функции экспоненциального типа  $\psi_k(\tau, \gamma)$ .

Замены переменных аргумента  $x = f(\tau, \gamma)$ , позволяющие определить функции Якоби и обобщенные функции Лагерра [3, 9] представлены в таблице ниже.

Название многочлена	Обозначение	Замена аргумента
	$\psi_k(\tau, \gamma)$	$x = f(\tau, \gamma)$
Обобщенные Лагерра	$L_k^{(\alpha)}(\tau, \gamma)$	$x = \gamma\tau$
Якоби	$P_k^{(\alpha, \beta)}(\tau, \gamma)$	$x = 1 - 2\exp(-c\gamma\tau)$

### 1.1 Аналитические соотношения для ортогональных функций

$$[1.1] \quad L_k(\tau, \gamma) = \sum_{s=0}^k \binom{k}{s} \frac{(-\gamma\tau)^s}{s!} \exp\left(-\frac{\gamma\tau}{2}\right).$$

Частные случаи для функций 0-5 порядков:

$$L_0(\tau, \gamma) = \exp\left(-\frac{\gamma\tau}{2}\right);$$

$$L_1(\tau, \gamma) = \exp\left(-\frac{\gamma\tau}{2}\right)(1 - \gamma\tau);$$

$$L_2(\tau, \gamma) = \exp\left(-\frac{\gamma\tau}{2}\right)(\gamma^2\tau^2 - 4\gamma\tau + 2)/2;$$

$$L_3(\tau, \gamma) = \exp\left(-\frac{\gamma\tau}{2}\right)(6 - 18\gamma\tau + 9\gamma^2\tau^2 - \gamma^3\tau^3)/6;$$

$$L_4(\tau, \gamma) = \exp\left(-\frac{\gamma\tau}{2}\right)(\gamma^4\tau^4 - 16\gamma^3\tau^3 + 72\gamma^2\tau^2 - 96\gamma\tau + 24)/24;$$

$$L_5(\tau, \gamma) = \exp\left(-\frac{\gamma\tau}{2}\right)(120 - 600\gamma\tau + 600\gamma^2\tau^2 - 200\gamma^3\tau^3 + 25 \times \gamma^4\tau^4 - \gamma^5\tau^5)/120.$$



Рис. 1.1. Вид ортогональных функций Лагерра 0-5 порядков;  $\gamma = 4$

$$[1.2] \quad L_k^{(1)}(\tau, \gamma) = \sum_{s=0}^k \binom{k+1}{k-s} \frac{(-\gamma\tau)^s}{s!} \exp\left(-\frac{\gamma\tau}{2}\right).$$

Частные случаи для функций 0-5 порядков:

$$L_0^{(1)}(\tau, \gamma) = \exp\left(-\frac{\gamma\tau}{2}\right);$$

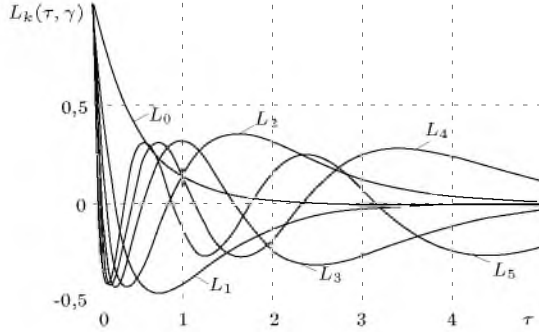
$$L_1^{(1)}(\tau, \gamma) = \exp\left(-\frac{\gamma\tau}{2}\right)(2 - \gamma\tau);$$

$$L_2^{(1)}(\tau, \gamma) = \exp\left(-\frac{\gamma\tau}{2}\right)(\gamma^2\tau^2 - 6\gamma\tau + 6)/2;$$

$$L_3^{(1)}(\tau, \gamma) = \exp\left(-\frac{\gamma\tau}{2}\right)(24 - 36\gamma\tau + 12\gamma^2\tau^2 - \gamma^3\tau^3)/6;$$

$$L_4^{(1)}(\tau, \gamma) = \exp\left(-\frac{\gamma\tau}{2}\right)(\gamma^4\tau^4 - 20\gamma^3\tau^3 + 120\gamma^2\tau^2 - 240\gamma\tau + 120)/24;$$

$$L_5^{(1)}(\tau, \gamma) = \exp\left(-\frac{\gamma\tau}{2}\right)(720 - 1800\gamma\tau + 1200\gamma^2\tau^2 - 300\gamma^3\tau^3 + 30\gamma^4\tau^4 - \gamma^5\tau^5)/120.$$



Рис. 1.2. Вид ортогональных функций Сонинна-Лагерра 0-5 порядков;  $\gamma = 4, \alpha = 1$

$$[1.3] \quad L_k^{(2)}(\tau, \gamma) = \sum_{s=0}^k \binom{k+2}{k-s} \frac{(-\gamma\tau)^s}{s!} \exp\left(-\frac{\gamma\tau}{2}\right).$$

Частные случаи для функций 0-5 порядков:

$$L_0^{(2)}(\tau, \gamma) = \exp\left(-\frac{\gamma\tau}{2}\right);$$

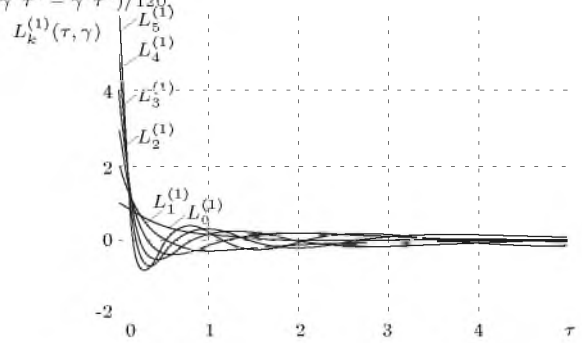
$$L_1^{(2)}(\tau, \gamma) = \exp\left(-\frac{\gamma\tau}{2}\right)(3 - \gamma\tau);$$

$$L_2^{(2)}(\tau, \gamma) = \exp\left(-\frac{\gamma\tau}{2}\right)(\gamma^2\tau^2 - 8\gamma\tau + 12)/2;$$

$$L_3^{(2)}(\tau, \gamma) = \exp\left(-\frac{\gamma\tau}{2}\right)(60 - 60\gamma\tau + 15\gamma^2\tau^2 - \gamma^3\tau^3)/6;$$

$$L_4^{(2)}(\tau, \gamma) = \exp\left(-\frac{\gamma\tau}{2}\right)(\gamma^4\tau^4 - 24\gamma^3\tau^3 + 180\gamma^2\tau^2 - 480\gamma\tau + 360)/24;$$

$$L_5^{(2)}(\tau, \gamma) = \exp\left(-\frac{\gamma\tau}{2}\right)(2520 - 4200\gamma\tau + 2100\gamma^2\tau^2 - 420\gamma^3\tau^3 + 35\gamma^4\tau^4 - \gamma^5\tau^5)/120.$$



Рис. 1.3. Вид ортогональных функций Сонина-Лагерра 0-5 порядков;  $\gamma = 4, \alpha = 2$

[1.4] 
$$L_k^{(\alpha)}(\tau, \gamma) = \sum_{s=0}^k \binom{k+\alpha}{k-s} \frac{(-\gamma\tau)^s}{s!} \exp\left(-\frac{\gamma\tau}{2}\right).$$

Частные случаи для функций 0-5 порядков:

$$L_0^{(\alpha)}(\tau, \gamma) = \exp\left(-\frac{\gamma\tau}{2}\right);$$

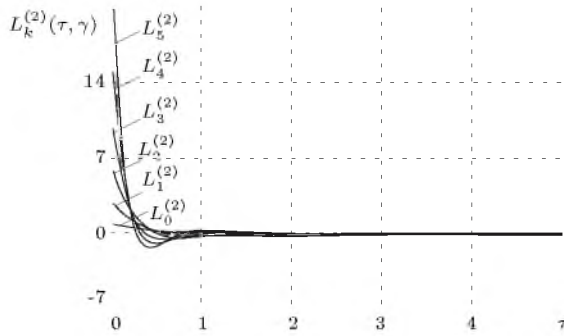
$$L_1^{(\alpha)}(\tau, \gamma) = \exp\left(-\frac{\gamma\tau}{2}\right)(\alpha + 1 - \gamma\tau);$$

$$L_2^{(\alpha)}(\tau, \gamma) = \frac{1}{2} \exp\left(-\frac{\gamma\tau}{2}\right)(\gamma^2\tau^2 - 2(\alpha + 2)\gamma\tau + (\alpha + 1)(\alpha + 2));$$

$$L_3^{(\alpha)}(\tau, \gamma) = \frac{1}{6} \exp\left(-\frac{\gamma\tau}{2}\right)((\alpha + 1)(\alpha + 2)(\alpha + 3) - 3(\alpha + 2) \times$$

$$\times (\alpha + 3)\gamma\tau + 3(\alpha + 3)\gamma^2\tau^2 - \gamma^3\tau^3);$$

$$L_4^{(\alpha)}(\tau, \gamma) = \frac{1}{24} \exp\left(-\frac{\gamma\tau}{2}\right)(\gamma^4\tau^4 - 4(\alpha + 4)\gamma^3\tau^3 + 6(\alpha + 3) \times$$

$$\times (\alpha + 4)\gamma^2\tau^2 - 4(\alpha + 2)(\alpha + 3)(\alpha + 4)\gamma\tau + (\alpha + 1)(\alpha + 2) \times$$

$$\times (\alpha + 3)(\alpha + 4));$$

$$L_5^{(\alpha)}(\tau, \gamma) = \frac{1}{120} \exp\left(-\frac{\gamma\tau}{2}\right)((\alpha + 1)(\alpha + 2)(\alpha + 3)(\alpha + 4) \times$$

$$\times (\alpha + 5) - 5(\alpha + 2)(\alpha + 3)(\alpha + 4)(\alpha + 5)\gamma\tau + 10(\alpha + 3)(\alpha + 4) \times$$

$$\times (\alpha + 5)\gamma^2\tau^2 - 10(\alpha + 4)(\alpha + 5)\gamma^3\tau^3 + 5(\alpha + 5)\gamma^4\tau^4 - \gamma^5\tau^5).$$



Рис. 1.4. Вид ортогональных функций Сонина-Лагерра 2-ого порядка: а)  $\gamma = 4, \alpha \in [0; 5]$ ; б)  $\gamma \in (0; 5], \alpha = 1$

[1.5] 
$$P_k^{(-1/2,0)}(\tau, \gamma) = \sum_{s=0}^k \binom{k}{s} \binom{k+s-1/2}{s-1/2} (-1)^s \times$$

$$\times \exp\left(-\frac{(4s+1)\gamma\tau}{2}\right).$$

Частные случаи для функций 0-5 порядков:

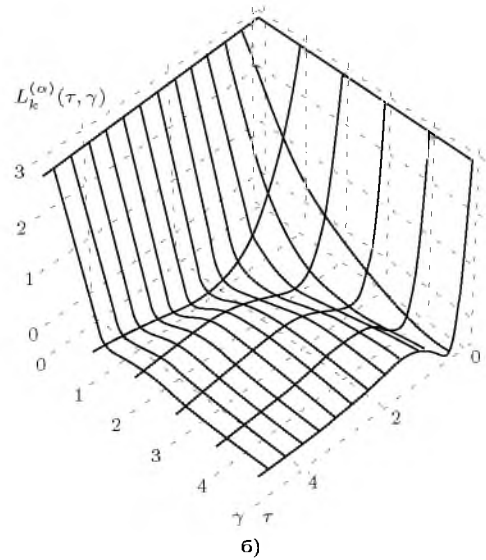
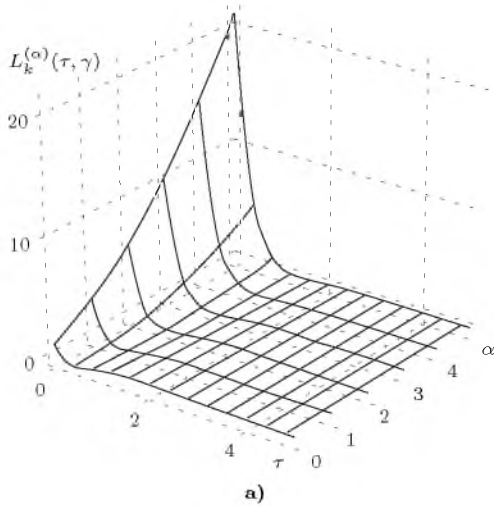
$$P_0^{(-1/2,0)}(\tau, \gamma) = \exp\left(-\frac{\gamma\tau}{2}\right);$$

$$P_1^{(-1/2,0)}(\tau, \gamma) = \exp\left(-\frac{\gamma\tau}{2}\right)(1 - 3\exp(-2\gamma\tau))/2;$$

$$P_2^{(-1/2,0)}(\tau, \gamma) = \exp\left(-\frac{\gamma\tau}{2}\right)(3 - 30\exp(-2\gamma\tau) + 35 \times$$

$$\times \exp(-4\gamma\tau))/8;$$

$$P_3^{(-1/2,0)}(\tau, \gamma) = \exp\left(-\frac{\gamma\tau}{2}\right)(5 - 105\exp(-2\gamma\tau) + 315 \times$$

$$\times \exp(-4\gamma\tau) - 231\exp(-6\gamma\tau))/16;$$

$$P_4^{(-1/2,0)}(\tau, \gamma) = \exp\left(-\frac{\gamma\tau}{2}\right)(35 - 1260\exp(-2\gamma\tau) + 6930 \times$$

$$\times \exp(-4\gamma\tau) - 12012\exp(-6\gamma\tau) + 6435\exp(-8\gamma\tau))/128;$$

$$P_5^{(-1/2,0)}(\tau, \gamma) = \exp\left(-\frac{\gamma\tau}{2}\right)(63 - 3465\exp(-2\gamma\tau) + 15015 \times$$

$$\times \exp(-4\gamma\tau) - 45045\exp(-6\gamma\tau) + 109395\exp(-8\gamma\tau) - 46189 \times$$

$$\times \exp(-10\gamma\tau))/256.$$



Рис. 1.5. Вид ортогональных функций Якоби 0-5 порядков;  $\gamma = 1, c = 2, \alpha = -1/2, \beta = 0$

$$[1.6] \quad Leg_k(\tau, \gamma) = \sum_{s=0}^k \binom{k}{s} \binom{k+s}{s} (-1)^s \exp(-(2s+1)\gamma\tau).$$

Частные случаи для функций 0-5 порядков:

$$Leg_0(\tau, \gamma) = \exp(-\gamma\tau);$$

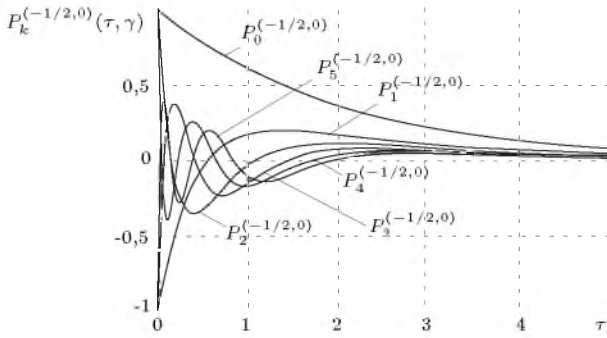
$$Leg_1(\tau, \gamma) = \exp(-\gamma\tau)(1 - 2\exp(-2\gamma\tau));$$

$$Leg_2(\tau, \gamma) = \exp(-\gamma\tau)(1 - 6\exp(-2\gamma\tau) + 6\exp(-4\gamma\tau));$$

$$Leg_3(\tau, \gamma) = \exp(-\gamma\tau)(1 - 12\exp(-2\gamma\tau) + 30\exp(-4\gamma\tau) - 20\exp(-6\gamma\tau));$$

$$Leg_4(\tau, \gamma) = \exp(-\gamma\tau)(1 - 20\exp(-2\gamma\tau) + 90\exp(-4\gamma\tau) - 140\exp(-6\gamma\tau) + 70\exp(-8\gamma\tau));$$

$$Leg_5(\tau, \gamma) = \exp(-\gamma\tau)(1 - 30\exp(-2\gamma\tau) + 210\exp(-4\gamma\tau) - 560\exp(-6\gamma\tau) + 630\exp(-8\gamma\tau) - 252\exp(-10\gamma\tau)).$$



Рис. 1.6. Вид ортогональных функций Лежандра 0-5 порядков;  $\gamma = 1, c = 2$

$$[1.7] \quad P_k^{(1/2,0)}(\tau, \gamma) = \sum_{s=0}^k \binom{k}{s} \binom{k+s+1/2}{s+1/2} (-1)^s \times \exp\left(-\frac{(4s+3)}{2}\gamma\tau\right).$$

Частные случаи для функций 0-5 порядков:

$$P_0^{(1/2,0)}(\tau, \gamma) = \exp\left(-\frac{3\gamma\tau}{2}\right);$$

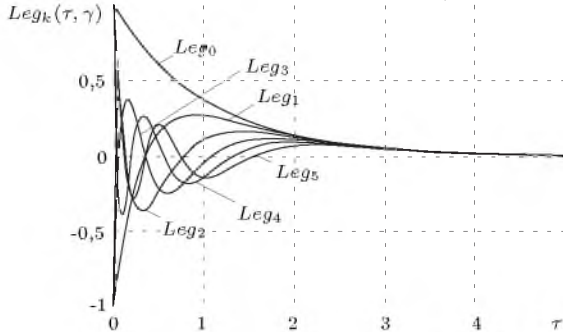
$$P_1^{(1/2,0)}(\tau, \gamma) = \exp\left(-\frac{3\gamma\tau}{2}\right)(3 - 5\exp(-2\gamma\tau))/2;$$

$$P_2^{(1/2,0)}(\tau, \gamma) = \exp\left(-\frac{3\gamma\tau}{2}\right)(15 - 70\exp(-2\gamma\tau) + 63 \times \exp(-4\gamma\tau))/8;$$

$$P_3^{(1/2,0)}(\tau, \gamma) = \exp\left(-\frac{3\gamma\tau}{2}\right)(35 - 315\exp(-2\gamma\tau) + 693 \times \exp(-4\gamma\tau) - 429\exp(-6\gamma\tau))/16;$$

$$P_4^{(1/2,0)}(\tau, \gamma) = \exp\left(-\frac{3\gamma\tau}{2}\right)(315 - 4620\exp(-2\gamma\tau) + 18018 \times \exp(-4\gamma\tau) - 25740\exp(-6\gamma\tau) + 12155\exp(-8\gamma\tau))/128;$$

$$P_5^{(1/2,0)}(\tau, \gamma) = \exp\left(-\frac{3\gamma\tau}{2}\right)(693 - 15015\exp(-2\gamma\tau) + 45045 \times \exp(-4\gamma\tau) - 218790\exp(-6\gamma\tau) + 230945\exp(-8\gamma\tau) - 88179 \times \exp(-10\gamma\tau))/256.$$



Рис. 1.7. Вид ортогональных функций Якоби 0-5 порядков;  $\gamma = 1, c = 2, \alpha = 1/2, \beta = 0$

$$[1.8] \quad P_k^{(1,0)}(\tau, \gamma) = \sum_{s=0}^k \binom{k}{s} \binom{k+s+1}{s+1} (-1)^s \times \exp(-(s+1)\gamma\tau).$$

Частные случаи для функций 0-5 порядков:

$$P_0^{(1,0)}(\tau, \gamma) = \exp(-\gamma\tau);$$

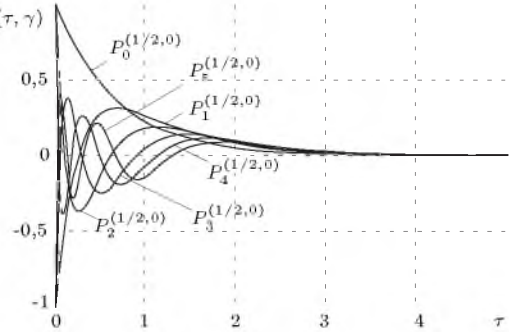
$$P_1^{(1,0)}(\tau, \gamma) = \exp(-\gamma\tau)(2 - 3\exp(-\gamma\tau));$$

$$P_2^{(1,0)}(\tau, \gamma) = \exp(-\gamma\tau)(3 - 12\exp(-\gamma\tau) + 10\exp(-2\gamma\tau));$$

$$P_3^{(1,0)}(\tau, \gamma) = \exp(-\gamma\tau)(4 - 30\exp(-\gamma\tau) + 60\exp(-2\gamma\tau) - 35\exp(-3\gamma\tau));$$

$$P_4^{(1,0)}(\tau, \gamma) = \exp(-\gamma\tau)(5 - 60\exp(-\gamma\tau) + 210\exp(-2\gamma\tau) - 280\exp(-3\gamma\tau) + 126\exp(-4\gamma\tau));$$

$$P_5^{(1,0)}(\tau, \gamma) = \exp(-\gamma\tau)(6 - 105\exp(-\gamma\tau) + 560\exp(-2\gamma\tau) - 1260\exp(-3\gamma\tau) + 1260\exp(-4\gamma\tau) - 462\exp(-5\gamma\tau)).$$



Рис. 1.8. Вид ортогональных функций Якоби 0-5 порядков;  $\gamma = 1, c = 1, \alpha = 1, \beta = 0$

$$[1.9] \quad P_k^{(2,0)}(\tau, \gamma) = \sum_{s=0}^k \binom{k}{s} \binom{k+s+2}{s+2} (-1)^s \times \\ \times \exp(-(2s+3)\gamma\tau).$$

Частные случаи для функций 0-5 порядков:

$$P_0^{(2,0)}(\tau, \gamma) = \exp(-3\gamma\tau);$$

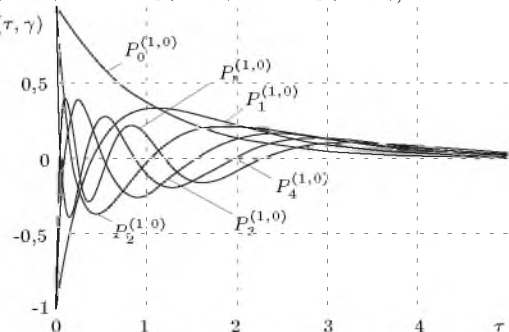
$$P_1^{(2,0)}(\tau, \gamma) = \exp(-3\gamma\tau)(3 - 4 \exp(-2\gamma\tau));$$

$$P_2^{(2,0)}(\tau, \gamma) = \exp(-3\gamma\tau)(6 - 20 \exp(-2\gamma\tau) + 15 \exp(-4\gamma\tau));$$

$$P_3^{(2,0)}(\tau, \gamma) = \exp(-3\gamma\tau)(10 - 60 \exp(-2\gamma\tau) + 105 \times \\ \times \exp(-4\gamma\tau) - 56 \exp(-6\gamma\tau));$$

$$P_4^{(2,0)}(\tau, \gamma) = \exp(-\gamma\tau)(15 - 140 \exp(-2\gamma\tau) + 420 \times \\ \times \exp(-4\gamma\tau) - 504 \exp(-6\gamma\tau) + 210 \exp(-8\gamma\tau));$$

$$P_5^{(2,0)}(\tau, \gamma) = \exp(-\gamma\tau)(21 - 280 \exp(-2\gamma\tau) + 1260 \times \\ \times \exp(-4\gamma\tau) - 2520 \exp(-6\gamma\tau) + 2310 \exp(-8\gamma\tau) - 792 \times \\ \times \exp(-10\gamma\tau)).$$



Рис. 1.9. Вид ортогональных функций Якоби 0-5 порядков;  $\gamma = 1, c = 2, \alpha = 2, \beta = 0$

$$[1.10] \quad P_k^{(\alpha,0)}(\tau, \gamma) = \sum_{s=0}^k \binom{k}{s} \binom{k+s+\alpha}{s+\alpha} (-1)^s \times \\ \times \exp(-(2s+\alpha+1)c\gamma\tau/2).$$

Частные случаи для функций 0-5 порядков:

$$P_0^{(\alpha,0)}(\tau, \gamma) = \exp(-(\alpha+1)c\gamma\tau/2);$$

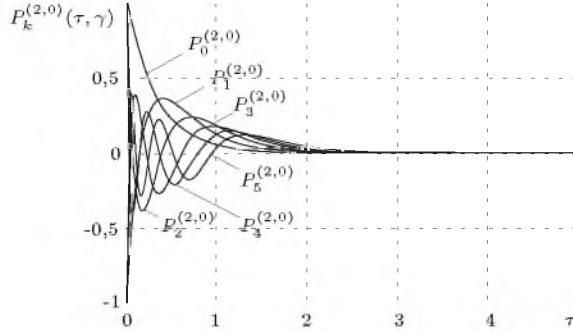
$$P_1^{(\alpha,0)}(\tau, \gamma) = \exp(-(\alpha+1)c\gamma\tau/2)(\alpha+1 - (\alpha+2)\exp(-c\gamma\tau));$$

$$P_2^{(\alpha,0)}(\tau, \gamma) = \exp(-(\alpha+1)c\gamma\tau/2)((\alpha+1)(\alpha+2) - 2(\alpha+2) \times \\ \times (\alpha+3)\exp(-c\gamma\tau) + (\alpha+3)(\alpha+4)\exp(-2c\gamma\tau))/2;$$

$$P_3^{(\alpha,0)}(\tau, \gamma) = \exp(-(\alpha+1)c\gamma\tau/2)((\alpha+1)(\alpha+2)(\alpha+3) - \\ - 3(\alpha+2)(\alpha+3)(\alpha+4)\exp(-c\gamma\tau) + 3(\alpha+3)(\alpha+4)(\alpha+5) \times \\ \times \exp(-2c\gamma\tau) - (\alpha+4)(\alpha+5)(\alpha+6)\exp(-3c\gamma\tau))/6;$$

$$P_4^{(\alpha,0)}(\tau, \gamma) = \exp(-(\alpha+1)c\gamma\tau/2)((\alpha+1)(\alpha+2)(\alpha+3) \times \\ \times (\alpha+4) - 4(\alpha+2)(\alpha+3)(\alpha+4)(\alpha+5)\exp(-c\gamma\tau) + 6(\alpha+3) \times \\ \times (\alpha+4)(\alpha+5)(\alpha+6)\exp(-2c\gamma\tau) - 4(\alpha+4)(\alpha+5)(\alpha+6) \times \\ \times (\alpha+7)\exp(-3c\gamma\tau) + (\alpha+5)(\alpha+6)(\alpha+7)(\alpha+8) \times \\ \times \exp(-4c\gamma\tau))/24;$$

$$P_5^{(\alpha,0)}(\tau, \gamma) = \exp(-(\alpha+1)c\gamma\tau/2)((\alpha+1)(\alpha+2)(\alpha+3) \times \\ \times (\alpha+4)(\alpha+5) - 5(\alpha+2)(\alpha+3)(\alpha+4)(\alpha+5)(\alpha+6) \times \\ \times \exp(-c\gamma\tau) + 10(\alpha+3)(\alpha+4)(\alpha+5)(\alpha+6)(\alpha+7) \times \\ \times \exp(-2c\gamma\tau) - 10(\alpha+4)(\alpha+5)(\alpha+6)(\alpha+7)(\alpha+8) \times \\ \times \exp(-3c\gamma\tau) + 5(\alpha+5)(\alpha+6)(\alpha+7)(\alpha+8)(\alpha+9) \times \\ \times \exp(-4c\gamma\tau) - (\alpha+6)(\alpha+7)(\alpha+8)(\alpha+9)(\alpha+10) \times \\ \times \exp(-5c\gamma\tau))/120.$$



Рис. 1.10. Вид ортогональных функций Якоби 2-ого порядка: а)  $\gamma = 1, c = 2, \alpha \in [0; 5], \beta = 0$ ; б)  $\gamma \in (0; 2], c = 2, \alpha = 1, \beta = 0$

$$[1.11] \quad P_k^{(0,1)}(\tau, \gamma) = \sum_{s=0}^k \binom{k}{s} \binom{k+s+1}{s} (-1)^s \times \\ \times \exp(-(2s+1)\gamma\tau).$$

Частные случаи для функций 0-5 порядков:

$$P_0^{(0,1)}(\tau, \gamma) = \exp(-\gamma\tau);$$

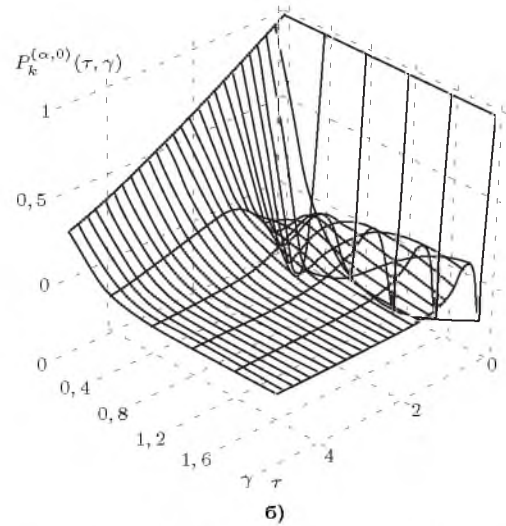
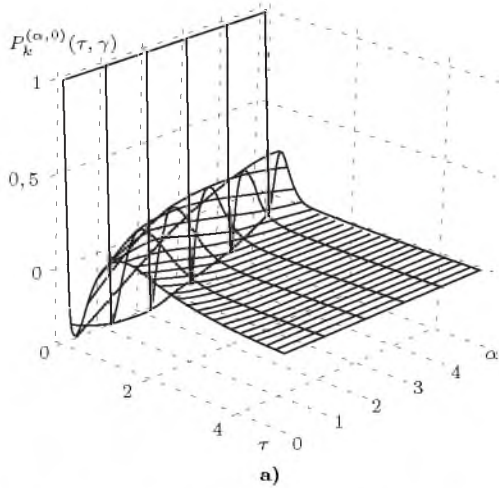
$$P_1^{(0,1)}(\tau, \gamma) = \exp(-\gamma\tau)(1 - 3 \exp(-2\gamma\tau));$$

$$\begin{aligned}
 P_2^{(0,1)}(\tau, \gamma) &= \exp(-\gamma\tau)(1 - 8 \exp(-2\gamma\tau) + 10 \exp(-4\gamma\tau)); \\
 P_3^{(0,1)}(\tau, \gamma) &= \exp(-\gamma\tau)(1 - 15 \exp(-2\gamma\tau) + 45 \exp(-4\gamma\tau) - \\
 &- 35 \exp(-6\gamma\tau)); \\
 P_4^{(0,1)}(\tau, \gamma) &= \exp(-\gamma\tau)(1 - 24 \exp(-2\gamma\tau) + 126 \exp(-4\gamma\tau) - \\
 &- 224 \exp(-6\gamma\tau) + 126 \exp(-8\gamma\tau)); \\
 P_5^{(0,1)}(\tau, \gamma) &= \exp(-\gamma\tau)(1 - 35 \exp(-2\gamma\tau) + 280 \exp(-4\gamma\tau) - \\
 &- 840 \exp(-6\gamma\tau) + 1050 \exp(-8\gamma\tau) - 462 \exp(-10\gamma\tau).
 \end{aligned}$$



Рис. 1.11. Вид ортогональных функций Якоби 0-5 порядков;  $\gamma = 1, c = 2, \alpha = 0, \beta = 1$

$$[1.12] \quad P_k^{(0,2)}(\tau, \gamma) = \sum_{s=0}^k \binom{k}{s} \binom{k+s+2}{s} (-1)^s \times \exp(-(2s+1)\gamma\tau).$$

Частные случаи для функций 0-5 порядков:

$$\begin{aligned}
 P_0^{(0,2)}(\tau, \gamma) &= \exp(-\gamma\tau); \\
 P_1^{(0,2)}(\tau, \gamma) &= \exp(-\gamma\tau)(1 - 4 \exp(-2\gamma\tau)); \\
 P_2^{(0,2)}(\tau, \gamma) &= \exp(-\gamma\tau)(1 - 10 \exp(-2\gamma\tau) + 15 \exp(-4\gamma\tau)); \\
 P_3^{(0,2)}(\tau, \gamma) &= \exp(-\gamma\tau)(1 - 18 \exp(-2\gamma\tau) + 63 \exp(-4\gamma\tau) - \\
 &- 56 \exp(-6\gamma\tau)); \\
 P_4^{(0,2)}(\tau, \gamma) &= \exp(-\gamma\tau)(1 - 28 \exp(-2\gamma\tau) + 168 \exp(-4\gamma\tau) - \\
 &- 336 \exp(-6\gamma\tau) + 210 \exp(-8\gamma\tau)); \\
 P_5^{(0,2)}(\tau, \gamma) &= \exp(-\gamma\tau)(1 - 40 \exp(-2\gamma\tau) + 360 \exp(-4\gamma\tau) -
 \end{aligned}$$

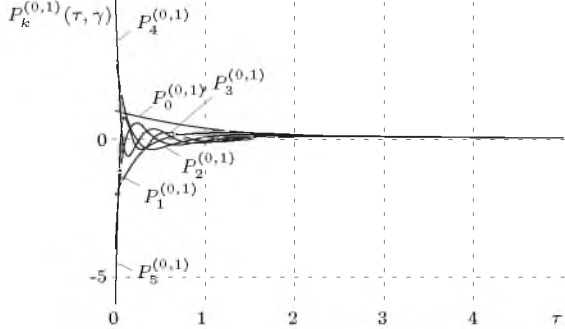
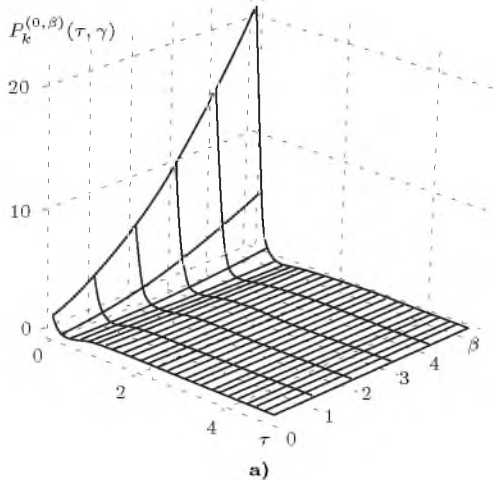

а)



Рис. 1.12. Вид ортогональных функций Якоби 0-5 порядков;  $\gamma = 1, c = 2, \alpha = 0, \beta = 2$

$$[1.13] \quad P_k^{(0,\beta)}(\tau, \gamma) = \sum_{s=0}^k \binom{k}{s} \binom{k+s+\beta}{s} (-1)^s \times \exp(-(2s+1)c\gamma\tau/2).$$

Частные случаи для функций 0-5 порядков:

$$\begin{aligned}
 P_0^{(0,\beta)}(\tau, \gamma) &= \exp(-c\gamma\tau/2); \\
 P_1^{(0,\beta)}(\tau, \gamma) &= \exp(-c\gamma\tau/2)(1 - (\beta+2) \exp(-c\gamma\tau)); \\
 P_2^{(0,\beta)}(\tau, \gamma) &= \exp(-c\gamma\tau/2)(1 - 2(\beta+3) \exp(-c\gamma\tau) + (\beta+3) \times \\
 &\times (\beta+4) \exp(-2c\gamma\tau/2)); \\
 P_3^{(0,\beta)}(\tau, \gamma) &= \exp(-c\gamma\tau/2)(1 - 3(\beta+4) \exp(-c\gamma\tau) + 3(\beta+4) \times \\
 &\times (\beta+5) \exp(-2c\gamma\tau/2) - (\beta+4)(\beta+5)(\beta+6) \exp(-3c\gamma\tau/6)); \\
 P_4^{(0,\beta)}(\tau, \gamma) &= \exp(-c\gamma\tau/2)(1 - 4(\beta+5) \exp(-c\gamma\tau) + 3(\beta+5) \times \\
 &\times (\beta+6) \exp(-2c\gamma\tau) - 2(\beta+5)(\beta+6)(\beta+7) \times \\
 &\times \exp(-3c\gamma\tau/3) + (\beta+5)(\beta+6)(\beta+7)(\beta+8) \exp(-4c\gamma\tau/24)); \\
 P_5^{(0,\beta)}(\tau, \gamma) &= \exp(-c\gamma\tau/2)(1 - 5(\beta+6) \exp(-c\gamma\tau) + 5(\beta+6) \times \\
 &\times (\beta+7) \exp(-2c\gamma\tau) - 5(\beta+6)(\beta+7)(\beta+8) \exp(-3c\gamma\tau/3) + \\
 &+ 5(\beta+6)(\beta+7)(\beta+8)(\beta+9) \exp(-4c\gamma\tau/24) - (\beta+6)(\beta+7) \times \\
 &\times (\beta+8)(\beta+9)(\beta+10) \exp(-5c\gamma\tau/120).
 \end{aligned}$$

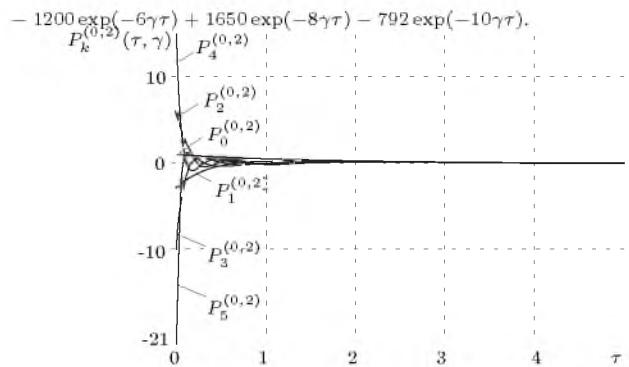
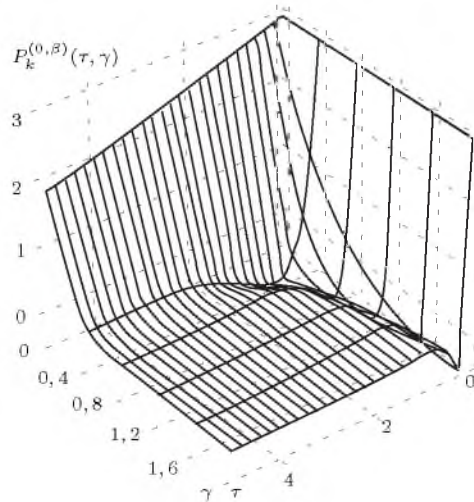

б)

Рис. 1.13. Вид ортогональных функций Якоби 2-ого порядка: а)  $\gamma = 1$ ,  $c = 2$ ,  $\beta \in [0; 5]$ ,  $\alpha = 0$ ; б)  $\gamma \in (0; 2]$ ,  $c = 2$ ,  $\alpha = 0$ ,  $\beta = 1$

## 1.2 Аналитические соотношения для производных ортогональных функций

$$[1.14] \quad \frac{\partial L_k(\tau, \gamma)}{\partial \tau} = -\gamma \left( \sum_{s=1}^k \binom{k}{s} \frac{(-\gamma\tau)^{s-1}}{(s-1)!} + \frac{1}{2} \sum_{s=0}^k \binom{k}{s} \frac{(-\gamma\tau)^s}{s!} \right) \exp\left(-\frac{\gamma\tau}{2}\right).$$

Частные случаи для 1-ой производной функций 0-5 порядков:

$$\begin{aligned} \frac{\partial L_0(\tau, \gamma)}{\partial \tau} &= -\frac{\gamma}{2} \exp\left(-\frac{\gamma\tau}{2}\right); \\ \frac{\partial L_1(\tau, \gamma)}{\partial \tau} &= \frac{\gamma}{2} \exp\left(-\frac{\gamma\tau}{2}\right)(\gamma\tau - 3); \\ \frac{\partial L_2(\tau, \gamma)}{\partial \tau} &= -\frac{\gamma}{4} \exp\left(-\frac{\gamma\tau}{2}\right)(\gamma^2\tau^2 - 8\gamma\tau + 10); \\ \frac{\partial L_3(\tau, \gamma)}{\partial \tau} &= \frac{\gamma}{12} \exp\left(-\frac{\gamma\tau}{2}\right)(\gamma^3\tau^3 - 15\gamma^2\tau^2 + 54\gamma\tau - 42); \\ \frac{\partial L_4(\tau, \gamma)}{\partial \tau} &= -\frac{\gamma}{48} \exp\left(-\frac{\gamma\tau}{2}\right)(\gamma^4\tau^4 - 24\gamma^3\tau^3 + 168\gamma^2\tau^2 - \\ &- 384\gamma\tau + 216); \\ \frac{\partial L_5(\tau, \gamma)}{\partial \tau} &= \frac{\gamma}{240} \exp\left(-\frac{\gamma\tau}{2}\right)(\gamma^5\tau^5 - 35\gamma^4\tau^4 + 400\gamma^3\tau^3 - \\ &- 1800\gamma^2\tau^2 + 3000\gamma\tau - 1320). \end{aligned}$$



Рис. 1.14. Вид 1-ой производной ортогональных функций Лагерра 0-5 порядков;  $\gamma = 1$

$$[1.15] \quad \frac{\partial^2 L_k(\tau, \gamma)}{\partial \tau^2} = \gamma^2 \left( \sum_{s=2}^k \binom{k}{s} \frac{(-\gamma\tau)^{s-2}}{(s-2)!} + \sum_{s=1}^k \binom{k}{s} \frac{(-\gamma\tau)^{s-1}}{(s-1)!} + \frac{1}{4} \sum_{s=0}^k \binom{k}{s} \frac{(-\gamma\tau)^s}{s!} \right) \exp\left(-\frac{\gamma\tau}{2}\right).$$

Частные случаи для 2-ой производной функций 0-5 порядков:

$$\begin{aligned} \frac{\partial^2 L_0(\tau, \gamma)}{\partial \tau^2} &= \frac{\gamma^2}{4} \exp\left(-\frac{\gamma\tau}{2}\right); \\ \frac{\partial^2 L_1(\tau, \gamma)}{\partial \tau^2} &= -\frac{\gamma^2}{4} \exp\left(-\frac{\gamma\tau}{2}\right)(\gamma\tau - 5); \\ \frac{\partial^2 L_2(\tau, \gamma)}{\partial \tau^2} &= \frac{\gamma^2}{8} \exp\left(-\frac{\gamma\tau}{2}\right)(\gamma^2\tau^2 - 12\gamma\tau + 26); \end{aligned}$$

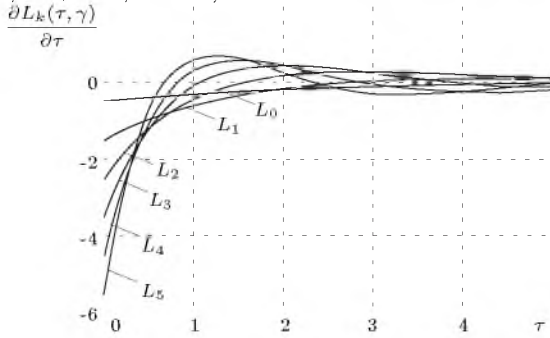
$$\frac{\partial^2 L_3(\tau, \gamma)}{\partial \tau^2} = -\frac{\gamma^2}{24} \exp\left(-\frac{\gamma\tau}{2}\right)(\gamma^3\tau^3 - 21\gamma^2\tau^2 + 114\gamma\tau - 150);$$

$$\frac{\partial^2 L_4(\tau, \gamma)}{\partial \tau^2} = \frac{\gamma^2}{96} \exp\left(-\frac{\gamma\tau}{2}\right)(\gamma^4\tau^4 - 32\gamma^3\tau^3 + 312\gamma^2\tau^2 - 1056\gamma\tau + 984);$$

$$\frac{\partial^2 L_5(\tau, \gamma)}{\partial \tau^2} = -\frac{\gamma^2}{480} \exp\left(-\frac{\gamma\tau}{2}\right)(\gamma^5\tau^5 - 45\gamma^4\tau^4 + 680\gamma^3\tau^3 - 4200\gamma^2\tau^2 + 10200\gamma\tau - 7320).$$



Рис. 1.15. Вид 2-ой производной ортогональных функций Лагерра 0-5 порядков;  $\gamma = 1$

$$[1.16] \quad \frac{\partial^3 L_k(\tau, \gamma)}{\partial \tau^3} = -\gamma^3 \left( \sum_{s=3}^k \binom{k}{s} \frac{(-\gamma\tau)^{s-3}}{(s-3)!} + \frac{3}{2} \sum_{s=2}^k \binom{k}{s} \frac{(-\gamma\tau)^{s-2}}{(s-2)!} + \frac{3}{4} \sum_{s=1}^k \binom{k}{s} \frac{(-\gamma\tau)^{s-1}}{(s-1)!} + \frac{1}{8} \sum_{s=0}^k \binom{k}{s} \frac{(-\gamma\tau)^s}{s!} \right) \exp\left(-\frac{\gamma\tau}{2}\right).$$

Частные случаи для 3-ой производной функций 0-5 порядков:

$$\frac{\partial^3 L_0(\tau, \gamma)}{\partial \tau^3} = -\frac{\gamma^3}{8} \exp\left(-\frac{\gamma\tau}{2}\right);$$

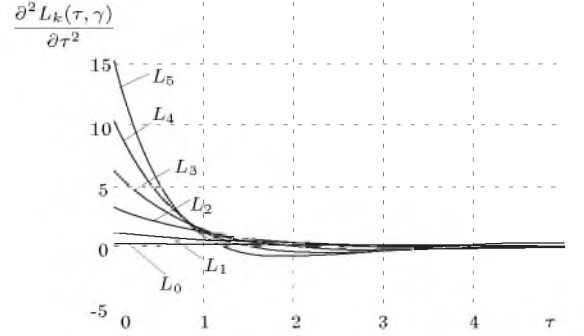
$$\frac{\partial^3 L_1(\tau, \gamma)}{\partial \tau^3} = \frac{\gamma^3}{8} \exp\left(-\frac{\gamma\tau}{2}\right)(\gamma\tau - 7);$$

$$\frac{\partial^3 L_2(\tau, \gamma)}{\partial \tau^3} = -\frac{\gamma^3}{16} \exp\left(-\frac{\gamma\tau}{2}\right)(\gamma^2\tau^2 - 16\gamma\tau + 50);$$

$$\frac{\partial^3 L_3(\tau, \gamma)}{\partial \tau^3} = \frac{\gamma^3}{48} \exp\left(-\frac{\gamma\tau}{2}\right)(\gamma^3\tau^3 - 27\gamma^2\tau^2 + 198\gamma\tau - 378);$$

$$\frac{\partial^3 L_4(\tau, \gamma)}{\partial \tau^3} = -\frac{\gamma^3}{192} \exp\left(-\frac{\gamma\tau}{2}\right)(\gamma^4\tau^4 - 40\gamma^3\tau^3 + 504\gamma^2\tau^2 - 2304\gamma\tau + 3096);$$

$$\frac{\partial^3 L_5(\tau, \gamma)}{\partial \tau^3} = \frac{\gamma^3}{960} \exp\left(-\frac{\gamma\tau}{2}\right)(\gamma^5\tau^5 - 55\gamma^4\tau^4 + 1040\gamma^3\tau^3 - 8280\gamma^2\tau^2 + 27000\gamma\tau - 27720).$$



Рис. 1.16. Вид 3-ой производной ортогональных функций Лагерра 0-5 порядков;  $\gamma = 1$

$$[1.17] \quad \frac{\partial^n L_k(\tau, \gamma)}{\partial \tau^n} = (-\gamma)^n \exp\left(-\frac{\gamma\tau}{2}\right) \sum_{j=0}^n \binom{n}{j} 2^{-j} \times \\ \times \sum_{s=0}^k \binom{k}{s} \begin{cases} \frac{(-\gamma\tau)^{s-n+j}}{(s-n+j)!}, & \text{если } s-n+j \geq 0; \\ 0, & \text{иначе.} \end{cases}$$

Частные случаи для n-ой производной функций 0-5 порядков:

$$\frac{\partial^n L_0(\tau, \gamma)}{\partial \tau^n} = (-\gamma)^n \exp\left(-\frac{\gamma\tau}{2}\right) \sum_{j=0}^n \binom{n}{j} 2^{-j} \times$$

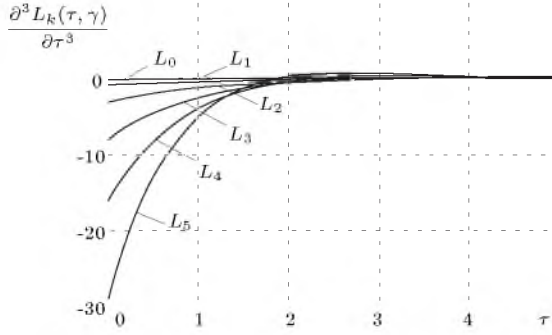
$$\times \begin{cases} \frac{(-\gamma\tau)^{-n+j}}{(-n+j)!}, & \text{если } -n+j \geq 0; \\ 0, & \text{иначе.} \end{cases}$$

$$\frac{\partial^n L_1(\tau, \gamma)}{\partial \tau^n} = (-\gamma)^n \exp\left(-\frac{\gamma\tau}{2}\right) \sum_{j=0}^n \binom{n}{j} 2^{-j} \times$$

$$\times \left( \begin{cases} \frac{(-\gamma\tau)^{-n+j}}{(-n+j)!}, & \text{если } -n+j \geq 0; \\ 0, & \text{иначе} \end{cases} + \begin{cases} \frac{(-\gamma\tau)^{1-n+j}}{(1-n+j)!}, & \text{если } 1-n+j \geq 0; \\ 0, & \text{иначе} \end{cases} \right);$$

$$\frac{\partial^n L_2(\tau, \gamma)}{\partial \tau^n} = (-\gamma)^n \exp\left(-\frac{\gamma\tau}{2}\right) \sum_{j=0}^n \binom{n}{j} 2^{-j} \times$$

$$\times \left( \begin{cases} \frac{(-\gamma\tau)^{-n+j}}{(-n+j)!}, & \text{если } -n+j \geq 0; \\ 0, & \text{иначе} \end{cases} + \begin{cases} \frac{2(-\gamma\tau)^{1-n+j}}{(1-n+j)!}, & \text{если } 1-n+j \geq 0; \\ 0, & \text{иначе} \end{cases} + \begin{cases} \frac{(-\gamma\tau)^{2-n+j}}{(2-n+j)!}, & \text{если } 2-n+j \geq 0; \\ 0, & \text{иначе} \end{cases} \right);$$

$$\frac{\partial^n L_3(\tau, \gamma)}{\partial \tau^n} = (-\gamma)^n \exp\left(-\frac{\gamma\tau}{2}\right) \sum_{j=0}^n \binom{n}{j} 2^{-j} \times$$

$$\times \left( \begin{cases} \frac{(-\gamma\tau)^{-n+j}}{(-n+j)!}, & \text{если } -n+j \geq 0; \\ 0, & \text{иначе} \end{cases} + \begin{cases} \frac{3(-\gamma\tau)^{1-n+j}}{(1-n+j)!}, & \text{если } 1-n+j \geq 0; \\ 0, & \text{иначе} \end{cases} \right);$$

$$+ \begin{cases} \frac{3(-\gamma\tau)^{2-n+j}}{(2-n+j)!}, & \text{если } 2-n+j \geq 0; \\ 0, & \text{иначе} \end{cases} + \begin{cases} \frac{(-\gamma\tau)^{3-n+j}}{(3-n+j)!}, & \text{если } 3-n+j \geq 0; \\ 0, & \text{иначе} \end{cases} \Big); \\ \frac{\partial^n L_4(\tau, \gamma)}{\partial \tau^n} = (-\gamma)^n \exp\left(-\frac{\gamma\tau}{2}\right) \sum_{j=0}^n \binom{n}{j} 2^{-j} \times$$

$$\times \left( \begin{cases} \frac{(-\gamma\tau)^{-n+j}}{(-n+j)!}, & \text{если } -n+j \geq 0; \\ 0, & \text{иначе} \end{cases} + \begin{cases} \frac{4(-\gamma\tau)^{1-n+j}}{(1-n+j)!}, & \text{если } 1-n+j \geq 0; \\ 0, & \text{иначе} \end{cases} + \begin{cases} \frac{6(-\gamma\tau)^{2-n+j}}{(2-n+j)!}, & \text{если } 2-n+j \geq 0; \\ 0, & \text{иначе} \end{cases} + \begin{cases} \frac{4(-\gamma\tau)^{3-n+j}}{(3-n+j)!}, & \text{если } 3-n+j \geq 0; \\ 0, & \text{иначе} \end{cases} + \begin{cases} \frac{(-\gamma\tau)^{4-n+j}}{(4-n+j)!}, & \text{если } 4-n+j \geq 0; \\ 0, & \text{иначе} \end{cases} \right);$$

$$+ \begin{cases} \frac{(-\gamma\tau)^{4-n+j}}{(4-n+j)!}, & \text{если } 4-n+j \geq 0; \\ 0, & \text{иначе} \end{cases} \Big); \\ \frac{\partial^n L_5(\tau, \gamma)}{\partial \tau^n} = (-\gamma)^n \exp\left(-\frac{\gamma\tau}{2}\right) \sum_{j=0}^n \binom{n}{j} 2^{-j} \times$$

$$\times \left( \begin{cases} \frac{(-\gamma\tau)^{-n+j}}{(-n+j)!}, & \text{если } -n+j \geq 0; \\ 0, & \text{иначе} \end{cases} + \begin{cases} \frac{5(-\gamma\tau)^{1-n+j}}{(1-n+j)!}, & \text{если } 1-n+j \geq 0; \\ 0, & \text{иначе} \end{cases} + \begin{cases} \frac{10(-\gamma\tau)^{2-n+j}}{(2-n+j)!}, & \text{если } 2-n+j \geq 0; \\ 0, & \text{иначе} \end{cases} + \begin{cases} \frac{10(-\gamma\tau)^{3-n+j}}{(3-n+j)!}, & \text{если } 3-n+j \geq 0; \\ 0, & \text{иначе} \end{cases} + \begin{cases} \frac{5(-\gamma\tau)^{4-n+j}}{(4-n+j)!}, & \text{если } 4-n+j \geq 0; \\ 0, & \text{иначе} \end{cases} + \begin{cases} \frac{(-\gamma\tau)^{5-n+j}}{(5-n+j)!}, & \text{если } 5-n+j \geq 0; \\ 0, & \text{иначе} \end{cases} \right).$$





Рис. 1.17. Вид n-ой производной ортогональных функций Лагерра 2-ого порядка;  $n = 0..5, \gamma = 1$

$$[1.18] \quad \frac{\partial L_k^{(1)}(\tau, \gamma)}{\partial \tau} = -\gamma \left( \sum_{s=1}^k \binom{k+1}{k-s} \frac{(-\gamma\tau)^{s-1}}{(s-1)!} + \frac{1}{2} \sum_{s=0}^k \binom{k+1}{k-s} \frac{(-\gamma\tau)^s}{s!} \right) \exp\left(-\frac{\gamma\tau}{2}\right).$$

Частные случаи для 1-ой производной функций 0-5 порядков:

$$\begin{aligned} \frac{\partial L_0^{(1)}(\tau, \gamma)}{\partial \tau} &= -\frac{\gamma}{2} \exp\left(-\frac{\gamma\tau}{2}\right); \\ \frac{\partial L_1^{(1)}(\tau, \gamma)}{\partial \tau} &= \frac{\gamma}{2} \exp\left(-\frac{\gamma\tau}{2}\right)(\gamma\tau - 4); \\ \frac{\partial L_2^{(1)}(\tau, \gamma)}{\partial \tau} &= -\frac{\gamma}{4} \exp\left(-\frac{\gamma\tau}{2}\right)(\gamma^2\tau^2 - 10\gamma\tau + 18); \\ \frac{\partial L_3^{(1)}(\tau, \gamma)}{\partial \tau} &= \frac{\gamma}{12} \exp\left(-\frac{\gamma\tau}{2}\right)(\gamma^3\tau^3 - 18\gamma^2\tau^2 + 84\gamma\tau - 96); \\ \frac{\partial L_4^{(1)}(\tau, \gamma)}{\partial \tau} &= -\frac{\gamma}{48} \exp\left(-\frac{\gamma\tau}{2}\right)(\gamma^4\tau^4 - 28\gamma^3\tau^3 + 240\gamma^2\tau^2 - \\ &- 720\gamma\tau + 600); \\ \frac{\partial L_5^{(1)}(\tau, \gamma)}{\partial \tau} &= \frac{\gamma}{240} \exp\left(-\frac{\gamma\tau}{2}\right)(\gamma^5\tau^5 - 40\gamma^4\tau^4 + 540\gamma^3\tau^3 - \\ &- 3000\gamma^2\tau^2 + 6600\gamma\tau - 4320). \end{aligned}$$

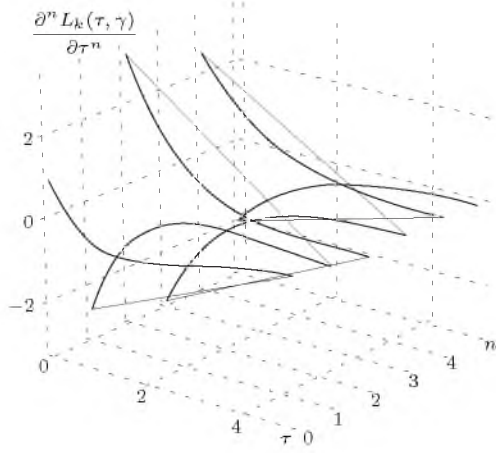

Рис. 1.18. Вид 1-ой производной ортогональных функций Сонина-Лагерра 0-5 порядков;  $\gamma = 1, \alpha = 1$

$$[1.19] \quad \frac{\partial^2 L_k^{(1)}(\tau, \gamma)}{\partial \tau^2} = \gamma^2 \left( \sum_{s=2}^k \binom{k+1}{k-s} \frac{(-\gamma\tau)^{s-2}}{(s-2)!} + \sum_{s=1}^k \binom{k+1}{k-s} \frac{(-\gamma\tau)^{s-1}}{(s-1)!} + \frac{1}{4} \sum_{s=0}^k \binom{k+1}{k-s} \frac{(-\gamma\tau)^s}{s!} \right) \exp\left(-\frac{\gamma\tau}{2}\right).$$

Частные случаи для 2-ой производной функций 0-5 порядков:

$$\begin{aligned} \frac{\partial^2 L_0^{(1)}(\tau, \gamma)}{\partial \tau^2} &= \frac{\gamma^2}{4} \exp\left(-\frac{\gamma\tau}{2}\right); \\ \frac{\partial^2 L_1^{(1)}(\tau, \gamma)}{\partial \tau^2} &= -\frac{\gamma^2}{4} \exp\left(-\frac{\gamma\tau}{2}\right)(\gamma\tau - 6); \\ \frac{\partial^2 L_2^{(1)}(\tau, \gamma)}{\partial \tau^2} &= \frac{\gamma^2}{8} \exp\left(-\frac{\gamma\tau}{2}\right)(\gamma^2\tau^2 - 14\gamma\tau + 38); \\ \frac{\partial^2 L_3^{(1)}(\tau, \gamma)}{\partial \tau^2} &= -\frac{\gamma^2}{24} \exp\left(-\frac{\gamma\tau}{2}\right)(\gamma^3\tau^3 - 24\gamma^2\tau^2 + 156\gamma\tau - 264); \\ \frac{\partial^2 L_4^{(1)}(\tau, \gamma)}{\partial \tau^2} &= \frac{\gamma^2}{96} \exp\left(-\frac{\gamma\tau}{2}\right)(\gamma^4\tau^4 - 36\gamma^3\tau^3 + 408\gamma^2\tau^2 - \\ &- 1680\gamma\tau + 2040); \\ \frac{\partial^2 L_5^{(1)}(\tau, \gamma)}{\partial \tau^2} &= -\frac{\gamma^2}{480} \exp\left(-\frac{\gamma\tau}{2}\right)(\gamma^5\tau^5 - 50\gamma^4\tau^4 + 860\gamma^3\tau^3 - \\ &- 6240\gamma^2\tau^2 + 18600\gamma\tau - 17520). \end{aligned}$$

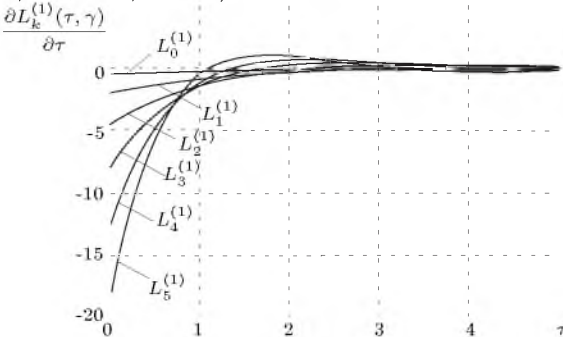

Рис. 1.19. Вид 2-ой производной ортогональных функций Сонина-Лагерра 0-5 порядков;  $\gamma = 1, \alpha = 1$

$$[1.20] \quad \frac{\partial^3 L_k^{(1)}(\tau, \gamma)}{\partial \tau^3} = -\gamma^3 \left( \sum_{s=3}^k \binom{k+1}{k-s} \frac{(-\gamma\tau)^{s-3}}{(s-3)!} + \frac{3}{2} \sum_{s=2}^k \binom{k+1}{k-s} \frac{(-\gamma\tau)^{s-2}}{(s-2)!} + \frac{3}{4} \sum_{s=1}^k \binom{k+1}{k-s} \frac{(-\gamma\tau)^{s-1}}{(s-1)!} + \frac{1}{8} \sum_{s=0}^k \binom{k+1}{k-s} \frac{(-\gamma\tau)^s}{s!} \right) \exp\left(-\frac{\gamma\tau}{2}\right).$$

Частные случаи для 3-ей производной функций 0-5 порядков:

$$\begin{aligned} \frac{\partial^3 L_0^{(1)}(\tau, \gamma)}{\partial \tau^3} &= -\frac{\gamma^3}{8} \exp\left(-\frac{\gamma\tau}{2}\right); \\ \frac{\partial^3 L_1^{(1)}(\tau, \gamma)}{\partial \tau^3} &= \frac{\gamma^3}{8} \exp\left(-\frac{\gamma\tau}{2}\right)(\gamma\tau - 8); \\ \frac{\partial^3 L_2^{(1)}(\tau, \gamma)}{\partial \tau^3} &= -\frac{\gamma^3}{16} \exp\left(-\frac{\gamma\tau}{2}\right)(\gamma^2\tau^2 - 18\gamma\tau + 66); \end{aligned}$$

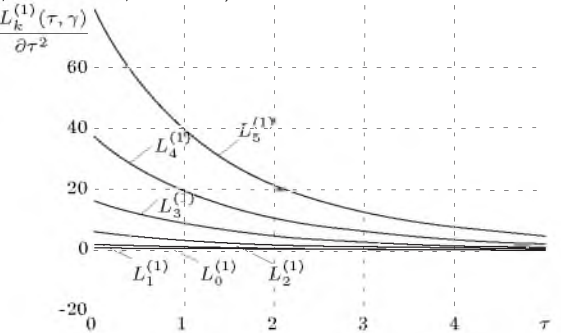

Рис. 1.20. Вид 3-ой производной ортогональных функций Сонина-Лагерра 0-5 порядков;  $\gamma = 1, \alpha = 1$

$$[1.21] \quad \frac{\partial^n L_k^{(1)}(\tau, \gamma)}{\partial \tau^n} = (-\gamma)^n \exp\left(-\frac{\gamma\tau}{2}\right) \sum_{j=0}^n \binom{n}{j} 2^{-j} \times$$

$$\times \sum_{s=0}^k \binom{k+1}{k-s} \begin{cases} \frac{(-\gamma\tau)^{s-n+j}}{(s-n+j)!}, & \text{если } s-n+j \geq 0; \\ 0, & \text{иначе.} \end{cases}$$

Частные случаи для n-ой производной функций 0-5 порядков:

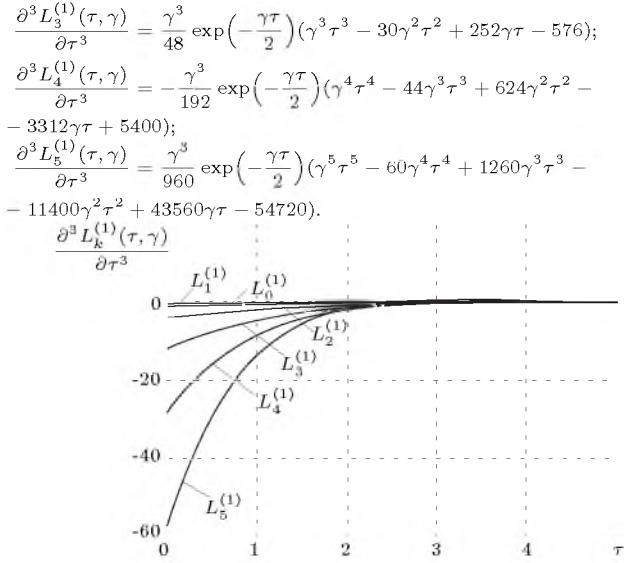
$$\frac{\partial^n L_0^{(1)}(\tau, \gamma)}{\partial \tau^n} = (-\gamma)^n \exp\left(-\frac{\gamma\tau}{2}\right) \sum_{j=0}^n \binom{n}{j} 2^{-j} \times$$

$$\times \begin{cases} \frac{(-\gamma\tau)^{-n+j}}{(-n+j)!}, & \text{если } -n+j \geq 0; \\ 0, & \text{иначе.} \end{cases}$$

$$\frac{\partial^n L_1^{(1)}(\tau, \gamma)}{\partial \tau^n} = (-\gamma)^n \exp\left(-\frac{\gamma\tau}{2}\right) \sum_{j=0}^n \binom{n}{j} 2^{-j} \times$$

$$\times \left( \begin{cases} \frac{2(-\gamma\tau)^{-n+j}}{(-n+j)!}, & \text{если } -n+j \geq 0; \\ 0, & \text{иначе} \end{cases} + \begin{cases} \frac{(-\gamma\tau)^{1-n+j}}{(1-n+j)!}, & \text{если } 1-n+j \geq 0; \\ 0, & \text{иначе} \end{cases} \right);$$

$$\frac{\partial^n L_2^{(1)}(\tau, \gamma)}{\partial \tau^n} = (-\gamma)^n \exp\left(-\frac{\gamma\tau}{2}\right) \sum_{j=0}^n \binom{n}{j} 2^{-j} \times$$

$$\times \left( \begin{cases} \frac{3(-\gamma\tau)^{-n+j}}{(-n+j)!}, & \text{если } -n+j \geq 0; \\ 0, & \text{иначе} \end{cases} + \begin{cases} \frac{3(-\gamma\tau)^{1-n+j}}{(1-n+j)!}, & \text{если } 1-n+j \geq 0; \\ 0, & \text{иначе} \end{cases} + \begin{cases} \frac{(-\gamma\tau)^{2-n+j}}{(2-n+j)!}, & \text{если } 2-n+j \geq 0; \\ 0, & \text{иначе} \end{cases} \right);$$

$$\frac{\partial^n L_3^{(1)}(\tau, \gamma)}{\partial \tau^n} = (-\gamma)^n \exp\left(-\frac{\gamma\tau}{2}\right) \sum_{j=0}^n \binom{n}{j} 2^{-j} \times$$

$$\times \left( \begin{cases} \frac{4(-\gamma\tau)^{-n+j}}{(-n+j)!}, & \text{если } -n+j \geq 0; \\ 0, & \text{иначе} \end{cases} + \begin{cases} \frac{6(-\gamma\tau)^{1-n+j}}{(1-n+j)!}, & \text{если } 1-n+j \geq 0; \\ 0, & \text{иначе} \end{cases} + \begin{cases} \frac{4(-\gamma\tau)^{2-n+j}}{(2-n+j)!}, & \text{если } 2-n+j \geq 0; \\ 0, & \text{иначе} \end{cases} + \begin{cases} \frac{(-\gamma\tau)^{3-n+j}}{(3-n+j)!}, & \text{если } 3-n+j \geq 0; \\ 0, & \text{иначе} \end{cases} \right);$$

$$\frac{\partial^n L_4^{(1)}(\tau, \gamma)}{\partial \tau^n} = (-\gamma)^n \exp\left(-\frac{\gamma\tau}{2}\right) \sum_{j=0}^n \binom{n}{j} 2^{-j} \times$$

$$\times \left( \begin{cases} \frac{5(-\gamma\tau)^{-n+j}}{(-n+j)!}, & \text{если } -n+j \geq 0; \\ 0, & \text{иначе} \end{cases} + \begin{cases} \frac{10(-\gamma\tau)^{1-n+j}}{(1-n+j)!}, & \text{если } 1-n+j \geq 0; \\ 0, & \text{иначе} \end{cases} + \begin{cases} \frac{10(-\gamma\tau)^{2-n+j}}{(2-n+j)!}, & \text{если } 2-n+j \geq 0; \\ 0, & \text{иначе} \end{cases} + \begin{cases} \frac{5(-\gamma\tau)^{3-n+j}}{(3-n+j)!}, & \text{если } 3-n+j \geq 0; \\ 0, & \text{иначе} \end{cases} + \begin{cases} \frac{(-\gamma\tau)^{4-n+j}}{(4-n+j)!}, & \text{если } 4-n+j \geq 0; \\ 0, & \text{иначе} \end{cases} \right);$$

$$\frac{\partial^n L_5^{(1)}(\tau, \gamma)}{\partial \tau^n} = (-\gamma)^n \exp\left(-\frac{\gamma\tau}{2}\right) \sum_{j=0}^n \binom{n}{j} 2^{-j} \times$$

$$\times \left( \begin{cases} \frac{6(-\gamma\tau)^{-n+j}}{(-n+j)!}, & \text{если } -n+j \geq 0; \\ 0, & \text{иначе} \end{cases} + \begin{cases} \frac{15(-\gamma\tau)^{1-n+j}}{(1-n+j)!}, & \text{если } 1-n+j \geq 0; \\ 0, & \text{иначе} \end{cases} + \begin{cases} \frac{20(-\gamma\tau)^{2-n+j}}{(2-n+j)!}, & \text{если } 2-n+j \geq 0; \\ 0, & \text{иначе} \end{cases} + \begin{cases} \frac{15(-\gamma\tau)^{3-n+j}}{(3-n+j)!}, & \text{если } 3-n+j \geq 0; \\ 0, & \text{иначе} \end{cases} + \begin{cases} \frac{6(-\gamma\tau)^{4-n+j}}{(4-n+j)!}, & \text{если } 4-n+j \geq 0; \\ 0, & \text{иначе} \end{cases} + \begin{cases} \frac{(-\gamma\tau)^{5-n+j}}{(5-n+j)!}, & \text{если } 5-n+j \geq 0; \\ 0, & \text{иначе} \end{cases} \right).$$



Рис. 1.21. Вид n-ой производной ортогональных функций Сонина-Лагерра 2-ого порядка;  $n = 0..5$ ,  $\gamma = 1$ ,  $\alpha = 1$

$$[1.22] \quad \frac{\partial L_k^{(2)}(\tau, \gamma)}{\partial \tau} = -\gamma \left( \sum_{s=1}^k \binom{k+2}{k-s} \frac{(-\gamma\tau)^{s-1}}{(s-1)!} + \frac{1}{2} \sum_{s=0}^k \binom{k+2}{k-s} \frac{(-\gamma\tau)^s}{s!} \right) \exp\left(-\frac{\gamma\tau}{2}\right).$$

Частные случаи для 1-ой производной функций 0-5 порядков:

$$\begin{aligned} \frac{\partial L_0^{(2)}(\tau, \gamma)}{\partial \tau} &= -\frac{\gamma}{2} \exp\left(-\frac{\gamma\tau}{2}\right); \\ \frac{\partial L_1^{(2)}(\tau, \gamma)}{\partial \tau} &= \frac{\gamma}{2} \exp\left(-\frac{\gamma\tau}{2}\right)(\gamma\tau - 5); \\ \frac{\partial L_2^{(2)}(\tau, \gamma)}{\partial \tau} &= -\frac{\gamma}{4} \exp\left(-\frac{\gamma\tau}{2}\right)(\gamma^2\tau^2 - 12\gamma\tau + 28); \\ \frac{\partial L_3^{(2)}(\tau, \gamma)}{\partial \tau} &= \frac{\gamma}{12} \exp\left(-\frac{\gamma\tau}{2}\right)(\gamma^3\tau^3 - 21\gamma^2\tau^2 + 120\gamma\tau - 180); \\ \frac{\partial L_4^{(2)}(\tau, \gamma)}{\partial \tau} &= -\frac{\gamma}{48} \exp\left(-\frac{\gamma\tau}{2}\right)(\gamma^4\tau^4 - 32\gamma^3\tau^3 + 324\gamma^2\tau^2 - \\ &- 1200\gamma\tau + 1320); \\ \frac{\partial L_5^{(2)}(\tau, \gamma)}{\partial \tau} &= \frac{\gamma}{240} \exp\left(-\frac{\gamma\tau}{2}\right)(\gamma^5\tau^5 - 45\gamma^4\tau^4 + 700\gamma^3\tau^3 - \\ &- 4620\gamma^2\tau^2 + 12600\gamma\tau - 10920). \end{aligned}$$

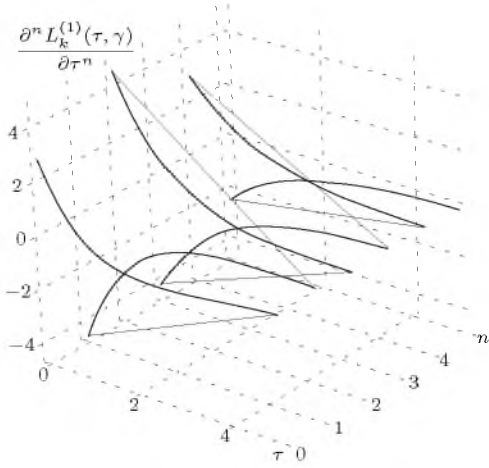

Рис. 1.22. Вид 1-ой производной ортогональных функций Сонина-Лагерра 0-5 порядков;  $\gamma = 1$ ,  $\alpha = 2$

$$[1.23] \quad \frac{\partial^2 L_k^{(2)}(\tau, \gamma)}{\partial \tau^2} = \gamma^2 \left( \sum_{s=2}^k \binom{k+2}{k-s} \frac{(-\gamma\tau)^{s-2}}{(s-2)!} + \sum_{s=1}^k \binom{k+2}{k-s} \frac{(-\gamma\tau)^{s-1}}{(s-1)!} + \frac{1}{4} \sum_{s=0}^k \binom{k+2}{k-s} \frac{(-\gamma\tau)^s}{s!} \right) \exp\left(-\frac{\gamma\tau}{2}\right).$$

Частные случаи для 2-ой производной функций 0-5 порядков:

$$\begin{aligned} \frac{\partial^2 L_0^{(2)}(\tau, \gamma)}{\partial \tau^2} &= \frac{\gamma^2}{4} \exp\left(-\frac{\gamma\tau}{2}\right); \\ \frac{\partial^2 L_1^{(2)}(\tau, \gamma)}{\partial \tau^2} &= -\frac{\gamma^2}{4} \exp\left(-\frac{\gamma\tau}{2}\right)(\gamma\tau - 7); \\ \frac{\partial^2 L_2^{(2)}(\tau, \gamma)}{\partial \tau^2} &= \frac{\gamma^2}{8} \exp\left(-\frac{\gamma\tau}{2}\right)(\gamma^2\tau^2 - 16\gamma\tau + 52); \\ \frac{\partial^2 L_3^{(2)}(\tau, \gamma)}{\partial \tau^2} &= -\frac{\gamma^2}{24} \exp\left(-\frac{\gamma\tau}{2}\right)(\gamma^3\tau^3 - 27\gamma^2\tau^2 + 204\gamma\tau - 420); \\ \frac{\partial^2 L_4^{(2)}(\tau, \gamma)}{\partial \tau^2} &= \frac{\gamma^2}{96} \exp\left(-\frac{\gamma\tau}{2}\right)(\gamma^4\tau^4 - 40\gamma^3\tau^3 + 516\gamma^2\tau^2 - \\ &- 2496\gamma\tau + 3720); \\ \frac{\partial^2 L_5^{(2)}(\tau, \gamma)}{\partial \tau^2} &= -\frac{\gamma^2}{480} \exp\left(-\frac{\gamma\tau}{2}\right)(\gamma^5\tau^5 - 55\gamma^4\tau^4 + 1060\gamma^3\tau^3 - \\ &- 8820\gamma^2\tau^2 + 31080\gamma\tau - 36120). \end{aligned}$$

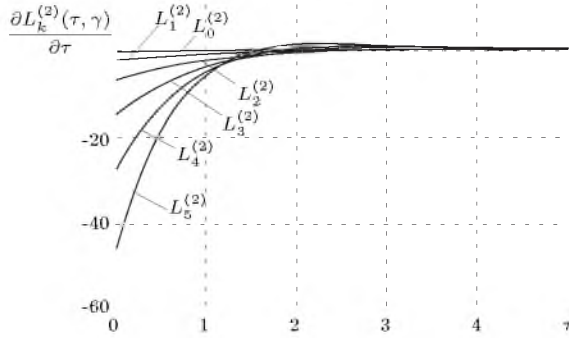

Рис. 1.23. Вид 2-ой производной ортогональных функций Сонина-Лагерра 0-5 порядков;  $\gamma = 1$ ,  $\alpha = 2$

$$[1.24] \quad \frac{\partial^3 L_k^{(2)}(\tau, \gamma)}{\partial \tau^3} = -\gamma^3 \left( \sum_{s=3}^k \binom{k+2}{k-s} \frac{(-\gamma\tau)^{s-3}}{(s-3)!} + \frac{3}{2} \sum_{s=2}^k \binom{k+2}{k-s} \frac{(-\gamma\tau)^{s-2}}{(s-2)!} + \frac{3}{4} \sum_{s=1}^k \binom{k+2}{k-s} \frac{(-\gamma\tau)^{s-1}}{(s-1)!} + \frac{1}{8} \sum_{s=0}^k \binom{k+2}{k-s} \frac{(-\gamma\tau)^s}{s!} \right) \exp\left(-\frac{\gamma\tau}{2}\right).$$

Частные случаи для 3-ей производной функций 0-5 порядков:

$$\begin{aligned} \frac{\partial^3 L_0^{(2)}(\tau, \gamma)}{\partial \tau^3} &= -\frac{\gamma^3}{8} \exp\left(-\frac{\gamma\tau}{2}\right); \\ \frac{\partial^3 L_1^{(2)}(\tau, \gamma)}{\partial \tau^3} &= \frac{\gamma^3}{8} \exp\left(-\frac{\gamma\tau}{2}\right)(\gamma\tau - 9); \\ \frac{\partial^3 L_2^{(2)}(\tau, \gamma)}{\partial \tau^3} &= -\frac{\gamma^3}{16} \exp\left(-\frac{\gamma\tau}{2}\right)(\gamma^2\tau^2 - 20\gamma\tau + 84); \end{aligned}$$

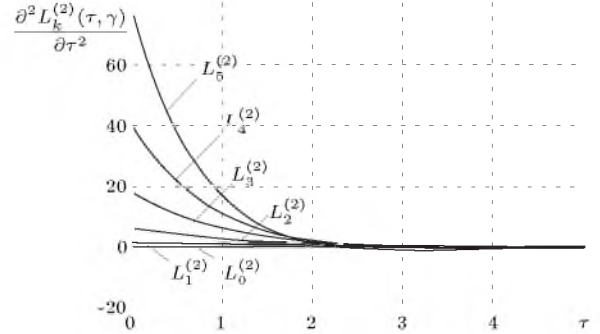

Рис. 1.24. Вид 3-ой производной ортогональных функций Сонина-Лагерра 0-5 порядков;  $\gamma = 1$ ,  $\alpha = 2$

$$[1.25] \quad \frac{\partial^n L_k^{(2)}(\tau, \gamma)}{\partial \tau^n} = (-\gamma)^n \exp\left(-\frac{\gamma\tau}{2}\right) \sum_{j=0}^n \binom{n}{j} 2^{-j} \times$$

$$\times \sum_{s=0}^k \binom{k+2}{k-s} \begin{cases} \frac{(-\gamma\tau)^{s-n+j}}{(s-n+j)!}, & \text{если } s-n+j \geq 0; \\ 0, & \text{иначе.} \end{cases}$$

Частные случаи для n-ой производной функций 0-5 порядков:

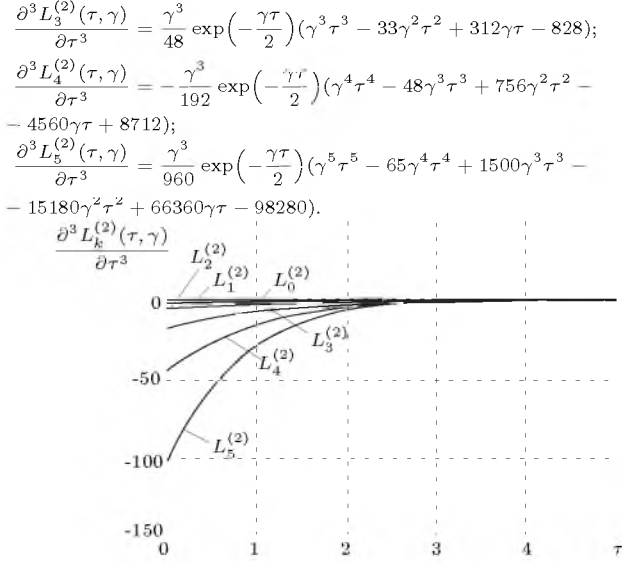
$$\frac{\partial^n L_0^{(2)}(\tau, \gamma)}{\partial \tau^n} = (-\gamma)^n \exp\left(-\frac{\gamma\tau}{2}\right) \sum_{j=0}^n \binom{n}{j} 2^{-j} \times$$

$$\times \begin{cases} \frac{(-\gamma\tau)^{-n+j}}{(-n+j)!}, & \text{если } -n+j \geq 0; \\ 0, & \text{иначе.} \end{cases}$$

$$\frac{\partial^n L_1^{(2)}(\tau, \gamma)}{\partial \tau^n} = (-\gamma)^n \exp\left(-\frac{\gamma\tau}{2}\right) \sum_{j=0}^n \binom{n}{j} 2^{-j} \times$$

$$\times \left( \begin{cases} \frac{3(-\gamma\tau)^{-n+j}}{(-n+j)!}, & \text{если } -n+j \geq 0; \\ 0, & \text{иначе} \end{cases} + \begin{cases} \frac{(-\gamma\tau)^{1-n+j}}{(1-n+j)!}, & \text{если } 1-n+j \geq 0; \\ 0, & \text{иначе} \end{cases} \right);$$

$$\frac{\partial^n L_2^{(2)}(\tau, \gamma)}{\partial \tau^n} = (-\gamma)^n \exp\left(-\frac{\gamma\tau}{2}\right) \sum_{j=0}^n \binom{n}{j} 2^{-j} \times$$

$$\times \left( \begin{cases} \frac{6(-\gamma\tau)^{-n+j}}{(-n+j)!}, & \text{если } -n+j \geq 0; \\ 0, & \text{иначе} \end{cases} + \begin{cases} \frac{4(-\gamma\tau)^{1-n+j}}{(1-n+j)!}, & \text{если } 1-n+j \geq 0; \\ 0, & \text{иначе} \end{cases} + \begin{cases} \frac{(-\gamma\tau)^{2-n+j}}{(2-n+j)!}, & \text{если } 2-n+j \geq 0; \\ 0, & \text{иначе} \end{cases} \right);$$

$$\frac{\partial^n L_3^{(2)}(\tau, \gamma)}{\partial \tau^n} = (-\gamma)^n \exp\left(-\frac{\gamma\tau}{2}\right) \sum_{j=0}^n \binom{n}{j} 2^{-j} \times$$

$$\times \left( \begin{cases} \frac{10(-\gamma\tau)^{-n+j}}{(-n+j)!}, & \text{если } -n+j \geq 0; \\ 0, & \text{иначе} \end{cases} + \begin{cases} \frac{10(-\gamma\tau)^{1-n+j}}{(1-n+j)!}, & \text{если } 1-n+j \geq 0; \\ 0, & \text{иначе} \end{cases} + \begin{cases} \frac{5(-\gamma\tau)^{2-n+j}}{(2-n+j)!}, & \text{если } 2-n+j \geq 0; \\ 0, & \text{иначе} \end{cases} + \begin{cases} \frac{(-\gamma\tau)^{3-n+j}}{(3-n+j)!}, & \text{если } 3-n+j \geq 0; \\ 0, & \text{иначе} \end{cases} \right);$$

$$\frac{\partial^n L_4^{(2)}(\tau, \gamma)}{\partial \tau^n} = (-\gamma)^n \exp\left(-\frac{\gamma\tau}{2}\right) \sum_{j=0}^n \binom{n}{j} 2^{-j} \times$$

$$\times \left( \begin{cases} \frac{15(-\gamma\tau)^{-n+j}}{(-n+j)!}, & \text{если } -n+j \geq 0; \\ 0, & \text{иначе} \end{cases} + \begin{cases} \frac{20(-\gamma\tau)^{1-n+j}}{(1-n+j)!}, & \text{если } 1-n+j \geq 0; \\ 0, & \text{иначе} \end{cases} + \begin{cases} \frac{15(-\gamma\tau)^{2-n+j}}{(2-n+j)!}, & \text{если } 2-n+j \geq 0; \\ 0, & \text{иначе} \end{cases} + \begin{cases} \frac{6(-\gamma\tau)^{3-n+j}}{(3-n+j)!}, & \text{если } 3-n+j \geq 0; \\ 0, & \text{иначе} \end{cases} + \begin{cases} \frac{(-\gamma\tau)^{4-n+j}}{(4-n+j)!}, & \text{если } 4-n+j \geq 0; \\ 0, & \text{иначе} \end{cases} \right);$$

$$\frac{\partial^n L_5^{(2)}(\tau, \gamma)}{\partial \tau^n} = (-\gamma)^n \exp\left(-\frac{\gamma\tau}{2}\right) \sum_{j=0}^n \binom{n}{j} 2^{-j} \times$$

$$\times \left( \begin{cases} \frac{21(-\gamma\tau)^{-n+j}}{(-n+j)!}, & \text{если } -n+j \geq 0; \\ 0, & \text{иначе} \end{cases} + \begin{cases} \frac{35(-\gamma\tau)^{1-n+j}}{(1-n+j)!}, & \text{если } 1-n+j \geq 0; \\ 0, & \text{иначе} \end{cases} + \begin{cases} \frac{35(-\gamma\tau)^{2-n+j}}{(2-n+j)!}, & \text{если } 2-n+j \geq 0; \\ 0, & \text{иначе} \end{cases} + \begin{cases} \frac{21(-\gamma\tau)^{3-n+j}}{(3-n+j)!}, & \text{если } 3-n+j \geq 0; \\ 0, & \text{иначе} \end{cases} + \begin{cases} \frac{7(-\gamma\tau)^{4-n+j}}{(4-n+j)!}, & \text{если } 4-n+j \geq 0; \\ 0, & \text{иначе} \end{cases} + \begin{cases} \frac{(-\gamma\tau)^{5-n+j}}{(5-n+j)!}, & \text{если } 5-n+j \geq 0; \\ 0, & \text{иначе} \end{cases} \right).$$



Рис. 1.25. Вид n-ой производной ортогональных функций Сонина-Лагерра 2-ого порядка;  $n = 0..5$ ,  $\gamma = 1$ ,  $\alpha = 2$

$$[1.26] \quad \frac{\partial L_k^{(\alpha)}(\tau, \gamma)}{\partial \tau} = -\gamma \left( \sum_{s=1}^k \binom{k+\alpha}{k-s} \frac{(-\gamma\tau)^{s-1}}{(s-1)!} + \frac{1}{2} \sum_{s=0}^k \binom{k+\alpha}{k-s} \frac{(-\gamma\tau)^s}{s!} \right) \exp\left(-\frac{\gamma\tau}{2}\right).$$

Частные случаи для 1-ой производной функций 0-5 порядков:

$$\frac{\partial L_0^{(\alpha)}(\tau, \gamma)}{\partial \tau} = -\frac{\gamma}{2} \exp\left(-\frac{\gamma\tau}{2}\right);$$

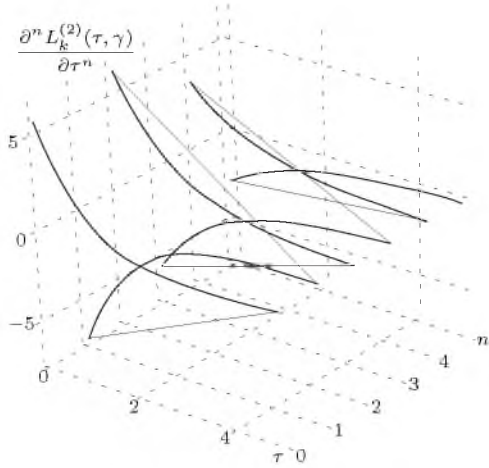
$$\frac{\partial L_1^{(\alpha)}(\tau, \gamma)}{\partial \tau} = \frac{\gamma}{2} \exp\left(-\frac{\gamma\tau}{2}\right) (\gamma\tau - \alpha - 3);$$

$$\frac{\partial L_2^{(\alpha)}(\tau, \gamma)}{\partial \tau} = -\frac{\gamma}{4} \exp\left(-\frac{\gamma\tau}{2}\right) (\gamma^2\tau^2 - 2(\alpha+4)\gamma\tau + \alpha^2 + 10);$$

$$\frac{\partial L_3^{(\alpha)}(\tau, \gamma)}{\partial \tau} = \frac{\gamma}{12} \exp\left(-\frac{\gamma\tau}{2}\right) (\gamma^3\tau^3 - 3(\alpha+5)\gamma^2\tau^2 + 3(\alpha^2 + 9\alpha + 18)\gamma\tau - \alpha^3 - 12\alpha^2 - 41\alpha - 42);$$

$$\frac{\partial L_4^{(\alpha)}(\tau, \gamma)}{\partial \tau} = -\frac{\gamma}{48} \exp\left(-\frac{\gamma\tau}{2}\right) (\gamma^4\tau^4 - 4(\alpha+6)\gamma^3\tau^3 + 6(\alpha^2 + 11\alpha + 28)\gamma^2\tau^2 - 4(\alpha^3 + 15\alpha^2 + 68\alpha + 96)\gamma\tau + \alpha^4 + 18\alpha^3 + 107\alpha^2 + 258\alpha + 216);$$

$$\frac{\partial L_5^{(\alpha)}(\tau, \gamma)}{\partial \tau} = \frac{\gamma}{240} \exp\left(-\frac{\gamma\tau}{2}\right) (\gamma^5\tau^5 - 5(\alpha+7)\gamma^4\tau^4 + 10(\alpha^2 + 13\alpha + 40)\gamma^3\tau^3 - 10(\alpha^3 + 18\alpha^2 + 101\alpha + 180)\gamma^2\tau^2 + 5(\alpha^4 + 22\alpha^3 + 167\alpha^2 + 530\alpha + 600)\gamma\tau - \alpha^5 - 25\alpha^4 - 225\alpha^3 - 935\alpha^2 - 1814\alpha - 1320).$$



Рис. 1.26. Вид 1-ой производной ортогональных функций Сонина-Лагерра 2-ого порядка: а)  $\gamma = 1$ ,  $\alpha \in [0; 5]$ ; б)  $\gamma \in (0; 5]$ ,  $\alpha = 1$

$$[1.27] \quad \frac{\partial^2 L_k^{(\alpha)}(\tau, \gamma)}{\partial \tau^2} = \gamma^2 \left( \sum_{s=2}^k \binom{k+\alpha}{k-s} \frac{(-\gamma\tau)^{s-2}}{(s-2)!} + \sum_{s=1}^k \binom{k+\alpha}{k-s} \frac{(-\gamma\tau)^{s-1}}{(s-1)!} + \frac{1}{4} \sum_{s=0}^k \binom{k+\alpha}{k-s} \frac{(-\gamma\tau)^s}{s!} \right) \exp\left(-\frac{\gamma\tau}{2}\right).$$

Частные случаи для 2-ой производной функций 0-5 порядков:

$$\frac{\partial^2 L_0^{(\alpha)}(\tau, \gamma)}{\partial \tau^2} = \frac{\gamma^2}{4} \exp\left(-\frac{\gamma\tau}{2}\right);$$

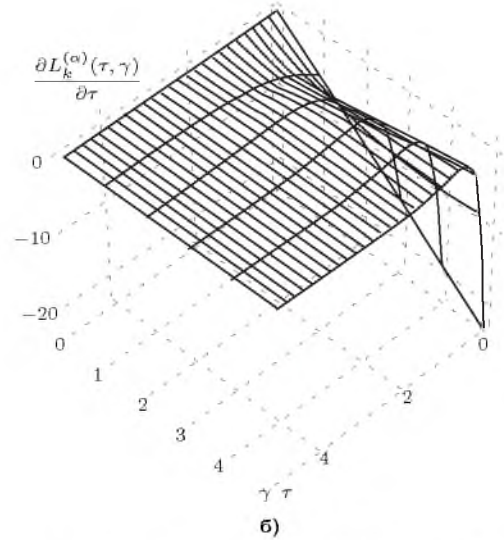
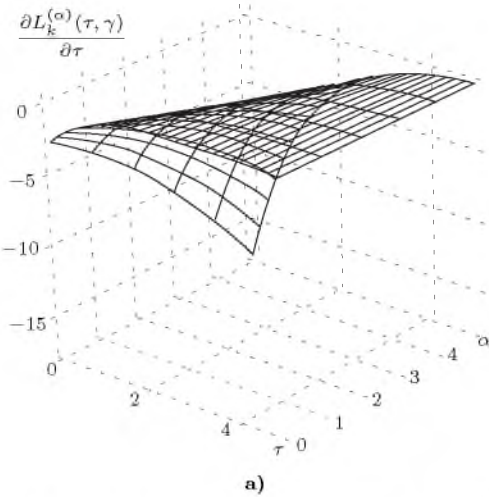
$$\begin{aligned}\frac{\partial^2 L_1^{(\alpha)}(\tau, \gamma)}{\partial \tau^2} &= -\frac{\gamma^2}{4} \exp\left(-\frac{\gamma\tau}{2}\right) (\gamma\tau - \alpha - 5); \\ \frac{\partial^2 L_2^{(\alpha)}(\tau, \gamma)}{\partial \tau^2} &= \frac{\gamma^2}{8} \exp\left(-\frac{\gamma\tau}{2}\right) (\gamma^2\tau^2 - 2(\alpha + 6)\gamma\tau + \alpha^2 + 11\alpha + \\ &+ 26); \\ \frac{\partial^2 L_3^{(\alpha)}(\tau, \gamma)}{\partial \tau^2} &= -\frac{\gamma^2}{24} \exp\left(-\frac{\gamma\tau}{2}\right) (\gamma^3\tau^3 - 3(\alpha + 7)\gamma^2\tau^2 + 3(\alpha^2 + \\ &+ 13\alpha + 38)\gamma\tau - \alpha^3 - 18\alpha^2 - 95\alpha - 150);\end{aligned}$$

$$\begin{aligned}\frac{\partial^2 L_4^{(\alpha)}(\tau, \gamma)}{\partial \tau^2} &= \frac{\gamma^2}{96} \exp\left(-\frac{\gamma\tau}{2}\right) (\gamma^4\tau^4 - 4(\alpha + 8)\gamma^3\tau^3 + 6(\alpha^2 + \\ &+ 15\alpha + 52)\gamma^2\tau^2 - 4(\alpha^3 + 21\alpha^2 + 134\alpha + 264)\gamma\tau + \alpha^4 + 26\alpha^3 + \\ &+ 227\alpha^2 + 802\alpha + 984); \\ \frac{\partial^2 L_5^{(\alpha)}(\tau, \gamma)}{\partial \tau^2} &= -\frac{\gamma^2}{480} \exp\left(-\frac{\gamma\tau}{2}\right) (\gamma^5\tau^5 - 5(\alpha + 9)\gamma^4\tau^4 + 10 \times \\ &\times (\alpha^2 + 17\alpha + 63)\gamma^3\tau^3 - 10(\alpha^3 + 24\alpha^2 + 179\alpha + 420)\gamma^2\tau^2 + \\ &+ 5(\alpha^4 + 30\alpha^3 + 311\alpha^2 + 1338\alpha + 2040)\gamma\tau - \alpha^5 - 35\alpha^4 - \\ &- 445\alpha^3 - 1555\alpha^2 - 7114\alpha - 7320).\end{aligned}$$



Рис. 1.27. Вид 2-ой производной ортогональных функций Сонина-Лагерра 2-ого порядка: а)  $\gamma = 1$ ,  $\alpha \in [0; 5]$ ; б)  $\gamma \in (0; 5]$ ,  $\alpha = 1$

$$\begin{aligned}[1.28] \quad \frac{\partial^3 L_k^{(\alpha)}(\tau, \gamma)}{\partial \tau^3} &= -\gamma^3 \left( \sum_{s=3}^k \binom{k+\alpha}{k-s} \frac{(-\gamma\tau)^{s-3}}{(s-3)!} + \right. \\ &+ \frac{3}{2} \sum_{s=2}^k \binom{k+\alpha}{k-s} \frac{(-\gamma\tau)^{s-2}}{(s-2)!} + \frac{3}{4} \sum_{s=1}^k \binom{k+\alpha}{k-s} \frac{(-\gamma\tau)^{s-1}}{(s-1)!} + \\ &\left. + \frac{1}{8} \sum_{s=0}^k \binom{k+\alpha}{k-s} \frac{(-\gamma\tau)^s}{s!} \right) \exp\left(-\frac{\gamma\tau}{2}\right).\end{aligned}$$

Частные случаи для 3-ей производной функций 0-5 порядков:

$$\frac{\partial^3 L_0^{(\alpha)}(\tau, \gamma)}{\partial \tau^3} = \frac{\gamma^3}{8} \exp\left(-\frac{\gamma\tau}{2}\right);$$

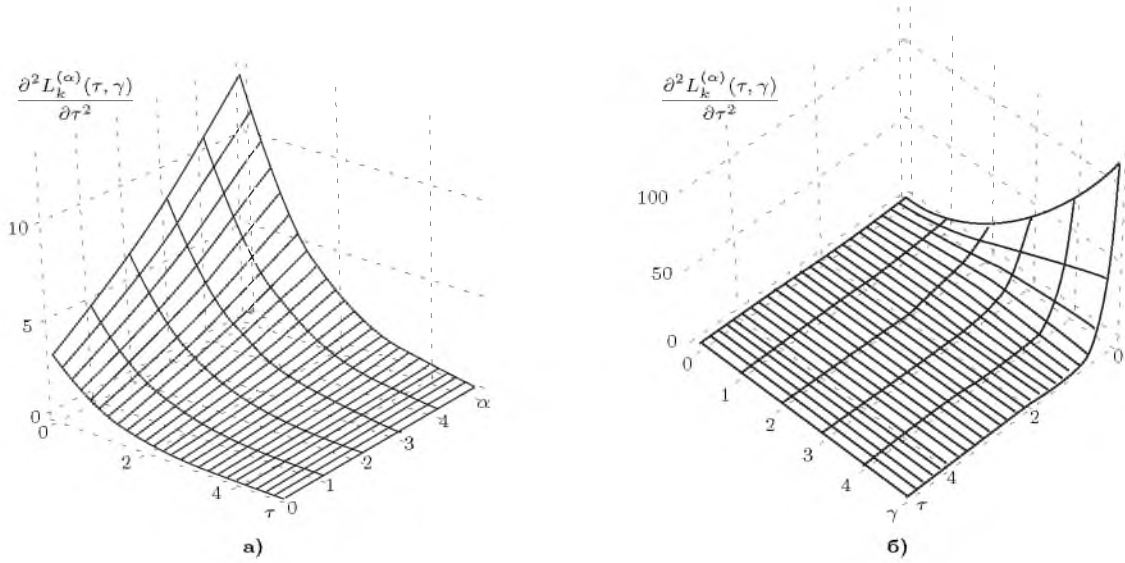
$$\frac{\partial^3 L_1^{(\alpha)}(\tau, \gamma)}{\partial \tau^3} = -\frac{\gamma^3}{8} \exp\left(-\frac{\gamma\tau}{2}\right) (\gamma\tau - \alpha - 7);$$

$$\begin{aligned}\frac{\partial^3 L_2^{(\alpha)}(\tau, \gamma)}{\partial \tau^3} &= \frac{\gamma^3}{16} \exp\left(-\frac{\gamma\tau}{2}\right) (\gamma^2\tau^2 - 2(\alpha + 8)\gamma\tau + \alpha^2 + 15\alpha + \\ &+ 50); \\ \frac{\partial^3 L_3^{(\alpha)}(\tau, \gamma)}{\partial \tau^3} &= -\frac{\gamma^3}{48} \exp\left(-\frac{\gamma\tau}{2}\right) (\gamma^3\tau^3 - 3(\alpha + 9)\gamma^2\tau^2 + 3(\alpha^2 + \\ &+ 17\alpha + 66)\gamma\tau - \alpha^3 - 24\alpha^2 - 173\alpha - 378); \\ \frac{\partial^3 L_4^{(\alpha)}(\tau, \gamma)}{\partial \tau^3} &= \frac{\gamma^3}{192} \exp\left(-\frac{\gamma\tau}{2}\right) (\gamma^4\tau^4 - 4(\alpha + 10)\gamma^3\tau^3 + 6(\alpha^2 + \\ &+ 19\alpha + 84)\gamma^2\tau^2 - 4(\alpha^3 + 27\alpha^2 + 224\alpha + 576)\gamma\tau + \alpha^4 + 34\alpha^3 + \\ &+ 395\alpha^2 + 1874\alpha + 3096); \\ \frac{\partial^3 L_5^{(\alpha)}(\tau, \gamma)}{\partial \tau^3} &= -\frac{\gamma^3}{960} \exp\left(-\frac{\gamma\tau}{2}\right) (\gamma^5\tau^5 - 5(\alpha + 11)\gamma^4\tau^4 + 10 \times \\ &\times (\alpha^2 + 21\alpha + 104)\gamma^3\tau^3 - 10(\alpha^3 + 30\alpha^2 + 281\alpha + 828)\gamma^2\tau^2 + \\ &+ 5(\alpha^4 + 38\alpha^3 + 503\alpha^2 + 2770\alpha + 5400)\gamma\tau - \alpha^5 - 45\alpha^4 - 745\alpha^3 - \\ &- 5715\alpha^2 - 20494\alpha - 27720).\end{aligned}$$

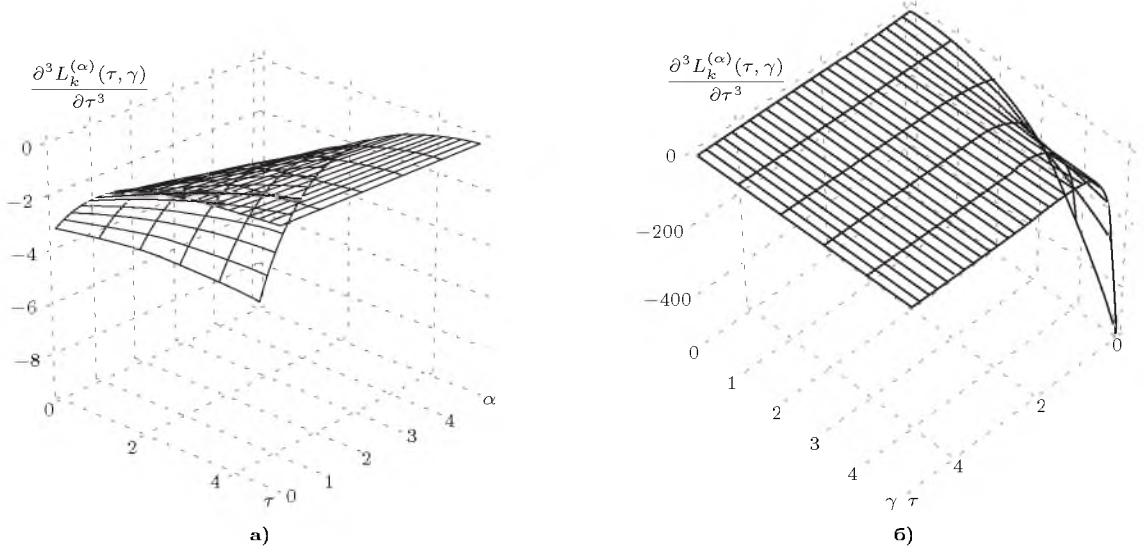
 Рис. 1.28. Вид 3-ой производной ортогональных функций Сонина-Лагерра 2-ого порядка: а)  $\gamma = 1$ ,  $\alpha \in [0; 5]$ ; б)  $\gamma \in (0; 5]$ ,  $\alpha = 1$ 

$$[1.29] \quad \frac{\partial^n L_k^{(\alpha)}(\tau, \gamma)}{\partial \tau^n} = (-\gamma)^n \exp\left(-\frac{\gamma\tau}{2}\right) \sum_{j=0}^n \binom{n}{j} 2^{-j} \times \\ \times \sum_{s=0}^k \binom{k+\alpha}{k-s} \begin{cases} \frac{(-\gamma\tau)^{s-n+j}}{(s-n+j)!}, & \text{если } s-n+j \geq 0; \\ 0, & \text{иначе.} \end{cases}$$

Частные случаи для n-ой производной функций 0-5 порядков:

$$\frac{\partial^n L_0^{(\alpha)}(\tau, \gamma)}{\partial \tau^n} = (-\gamma)^n \exp\left(-\frac{\gamma\tau}{2}\right) \sum_{j=0}^n \binom{n}{j} 2^{-j} \times \\ \begin{cases} \frac{(-\gamma\tau)^{-n+j}}{(-n+j)!}, & \text{если } -n+j \geq 0; \\ 0, & \text{иначе.} \end{cases} \\ \frac{\partial^n L_1^{(\alpha)}(\tau, \gamma)}{\partial \tau^n} = (-\gamma)^n \exp\left(-\frac{\gamma\tau}{2}\right) \sum_{j=0}^n \binom{n}{j} 2^{-j} \times \\ \times \left( \begin{cases} \frac{(\alpha+1)(-\gamma\tau)^{-n+j}}{(-n+j)!}, & \text{если } -n+j \geq 0; \\ 0, & \text{иначе} \end{cases} + \begin{cases} \frac{(-\gamma\tau)^{1-n+j}}{(1-n+j)!}, & \text{если } 1-n+j \geq 0; \\ 0, & \text{иначе} \end{cases} \right); \\ \frac{\partial^n L_2^{(\alpha)}(\tau, \gamma)}{\partial \tau^n} = (-\gamma)^n \exp\left(-\frac{\gamma\tau}{2}\right) \sum_{j=0}^n \binom{n}{j} 2^{-j} \times \\ \times \left( \begin{cases} \frac{(\alpha+1)(\alpha+2)(-\gamma\tau)^{-n+j}}{2(-n+j)!}, & \text{если } -n+j \geq 0; \\ 0, & \text{иначе} \end{cases} + \begin{cases} \frac{(\alpha+2)(-\gamma\tau)^{1-n+j}}{(1-n+j)!}, & \text{если } 1-n+j \geq 0; \\ 0, & \text{иначе} \end{cases} + \begin{cases} \frac{(-\gamma\tau)^{2-n+j}}{(2-n+j)!}, & \text{если } 2-n+j \geq 0; \\ 0, & \text{иначе} \end{cases} \right);$$

$$\frac{\partial^n L_3^{(\alpha)}(\tau, \gamma)}{\partial \tau^n} = (-\gamma)^n \exp\left(-\frac{\gamma\tau}{2}\right) \sum_{j=0}^n \binom{n}{j} 2^{-j} \times \\ \times \left( \begin{cases} \frac{(\alpha+3)(-\gamma\tau)^{-n+j}}{6\alpha!(-n+j)!}, & \text{если } -n+j \geq 0; \\ 0, & \text{иначе} \end{cases} + \begin{cases} \frac{(\alpha+2)(\alpha+3)(-\gamma\tau)^{1-n+j}}{2(1-n+j)!}, & \text{если } 1-n+j \geq 0; \\ 0, & \text{иначе} \end{cases} + \begin{cases} \frac{(\alpha+3)(-\gamma\tau)^{2-n+j}}{(2-n+j)!}, & \text{если } 2-n+j \geq 0; \\ 0, & \text{иначе} \end{cases} + \begin{cases} \frac{(-\gamma\tau)^{3-n+j}}{(3-n+j)!}, & \text{если } 3-n+j \geq 0; \\ 0, & \text{иначе} \end{cases} \right); \\ \frac{\partial^n L_4^{(\alpha)}(\tau, \gamma)}{\partial \tau^n} = (-\gamma)^n \exp\left(-\frac{\gamma\tau}{2}\right) \sum_{j=0}^n \binom{n}{j} 2^{-j} \times \\ \times \left( \begin{cases} \frac{(\alpha+4)(-\gamma\tau)^{-n+j}}{24\alpha!(-n+j)!}, & \text{если } -n+j \geq 0; \\ 0, & \text{иначе} \end{cases} + \begin{cases} \frac{(\alpha+3)(-\gamma\tau)^{1-n+j}}{6(\alpha+1)!(1-n+j)!}, & \text{если } 1-n+j \geq 0; \\ 0, & \text{иначе} \end{cases} + \begin{cases} \frac{(\alpha+3)(\alpha+4)(-\gamma\tau)^{2-n+j}}{2(2-n+j)!}, & \text{если } 2-n+j \geq 0; \\ 0, & \text{иначе} \end{cases} + \begin{cases} \frac{(\alpha+4)(-\gamma\tau)^{3-n+j}}{(3-n+j)!}, & \text{если } 3-n+j \geq 0; \\ 0, & \text{иначе} \end{cases} + \begin{cases} \frac{(-\gamma\tau)^{4-n+j}}{(4-n+j)!}, & \text{если } 4-n+j \geq 0; \\ 0, & \text{иначе} \end{cases} \right); \\ \frac{\partial^n L_5^{(\alpha)}(\tau, \gamma)}{\partial \tau^n} = (-\gamma)^n \exp\left(-\frac{\gamma\tau}{2}\right) \sum_{j=0}^n \binom{n}{j} 2^{-j} \times$$

$$\times \left( \begin{aligned} & \left\{ \frac{(\alpha + 5)!(-\gamma\tau)^{-n+j}}{120\alpha!(-n+j)!}, \text{ если } -n+j \geq 0; + \right. \\ & \left. 0, \text{ иначе} \right. \\ & + \left\{ \frac{(\alpha + 5)!(-\gamma\tau)^{1-n+j}}{24(\alpha + 1)!(1-n+j)!}, \text{ если } 1-n+j \geq 0; + \right. \\ & \left. 0, \text{ иначе} \right. \\ & + \left\{ \frac{(\alpha + 5)!(-\gamma\tau)^{2-n+j}}{6(\alpha + 2)!(2-n+j)!}, \text{ если } 2-n+j \geq 0; + \right. \\ & \left. 0, \text{ иначе} \right. \end{aligned} \right) \left| \begin{aligned} & + \left\{ \frac{(\alpha + 4)(\alpha + 5)(-\gamma\tau)^{3-n+j}}{2(3-n+j)!}, \text{ если } 3-n+j \geq 0; + \right. \\ & \left. 0, \text{ иначе} \right. \\ & + \left\{ \frac{(\alpha + 5)(-\gamma\tau)^{4-n+j}}{(4-n+j)!}, \text{ если } 4-n+j \geq 0; + \right. \\ & \left. 0, \text{ иначе} \right. \\ & + \left. \left. \left\{ \frac{(-\gamma\tau)^{5-n+j}}{(5-n+j)!}, \text{ если } 5-n+j \geq 0; \right. \right. \right. \\ & \left. \left. \left. 0, \text{ иначе} \right. \right. \right. \end{aligned} \right).$$



Рис. 1.29. Вид n-ой производной ортогональных функций Сонина-Лагерра 2-ого порядка: а)  $n = 0.5, \gamma = 1, \alpha \in [0; 5]$ ; б)  $n = 0.5, \gamma \in (0; 5], \alpha = 1$

[1.30] 
$$\frac{\partial P_k^{(-1/2,0)}(\tau, \gamma)}{\partial \tau} = -\frac{\gamma}{2} \sum_{s=0}^k \binom{k}{s} \binom{k+s-1/2}{s-1/2} \times (-1)^s (4s+1) \exp\left(-\frac{(4s+1)}{2}\gamma\tau\right).$$

Частные случаи для 1-ой производной функций 0-5 порядков:

$$\frac{\partial P_0^{(-1/2,0)}(\tau, \gamma)}{\partial \tau} = -\frac{\gamma}{2} \exp\left(-\frac{\gamma\tau}{2}\right);$$

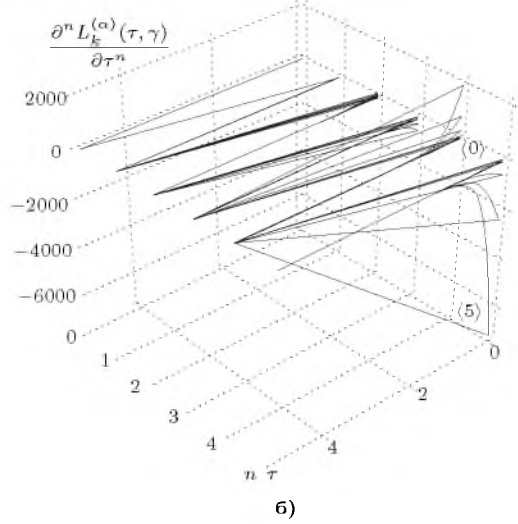
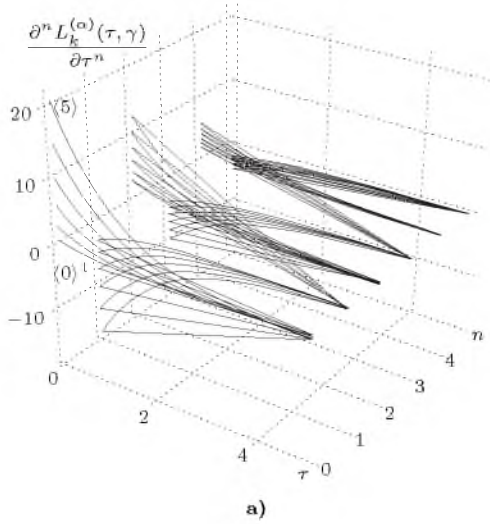
$$\frac{\partial P_1^{(-1/2,0)}(\tau, \gamma)}{\partial \tau} = \frac{\gamma}{4} \exp\left(-\frac{\gamma\tau}{2}\right) (15 \exp(-2\gamma\tau) - 1);$$

$$\frac{\partial P_2^{(-1/2,0)}(\tau, \gamma)}{\partial \tau} = -\frac{\gamma}{16} \exp\left(-\frac{\gamma\tau}{2}\right) (315 \exp(-4\gamma\tau) - 150 \exp(-2\gamma\tau) + 3);$$

$$\frac{\partial P_3^{(-1/2,0)}(\tau, \gamma)}{\partial \tau} = \frac{\gamma}{32} \exp\left(-\frac{\gamma\tau}{2}\right) (3003 \exp(-6\gamma\tau) - 2835 \exp(-4\gamma\tau) + 525 \exp(-2\gamma\tau) - 5);$$

$$\frac{\partial P_4^{(-1/2,0)}(\tau, \gamma)}{\partial \tau} = -\frac{\gamma}{256} \exp\left(-\frac{\gamma\tau}{2}\right) (109395 \exp(-8\gamma\tau) - 156156 \exp(-6\gamma\tau) + 62370 \exp(-4\gamma\tau) - 6300 \exp(-2\gamma\tau) + 35);$$

$$\frac{\partial P_5^{(-1/2,0)}(\tau, \gamma)}{\partial \tau} = \frac{\gamma}{512} \exp\left(-\frac{\gamma\tau}{2}\right) (969969 \exp(-10\gamma\tau) - 1859715 \exp(-8\gamma\tau) + 1171170 \exp(-6\gamma\tau) - 270270 \times \exp(-4\gamma\tau) + 17325 \exp(-2\gamma\tau) - 63).$$



Рис. 1.30. Вид 1-ой производной ортогональных функций Якоби 0-5 порядков;  $\gamma = 0,25, c = 2, \alpha = -1/2, \beta = 0$

<sup>1</sup>числовой эквивалент, характеризующий порядок кривой при изменении анализируемого параметра с равномерным шагом в выбранном диапазоне. Например, параметр  $\alpha \in [0; 5]$ : (0) - кривая при значении  $\alpha = 0$ , (5) - кривая при значении  $\alpha = 5$ .

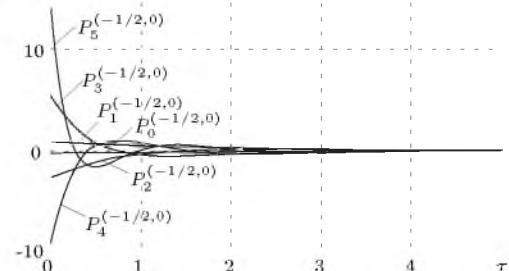

$$[1.31] \quad \frac{\partial^2 P_k^{(-1/2,0)}(\tau, \gamma)}{\partial \tau^2} = \frac{\gamma^2}{4} \sum_{s=0}^k \binom{k}{s} \binom{k+s-1/2}{s-1/2} \times (-1)^s (4s+1)^2 \exp\left(-\frac{(4s+1)}{2} \gamma \tau\right).$$

Частные случаи для 2-ой производной функций 0-5 порядков:

$$\begin{aligned} \frac{\partial^2 P_0^{(-1/2,0)}(\tau, \gamma)}{\partial \tau^2} &= \frac{\gamma^2}{4} \exp\left(-\frac{\gamma \tau}{2}\right); \\ \frac{\partial^2 P_1^{(-1/2,0)}(\tau, \gamma)}{\partial \tau^2} &= -\frac{\gamma^2}{8} \exp\left(-\frac{\gamma \tau}{2}\right) (75 \exp(-2\gamma \tau) - 1); \\ \frac{\partial^2 P_2^{(-1/2,0)}(\tau, \gamma)}{\partial \tau^2} &= \frac{3\gamma^2}{32} \exp\left(-\frac{\gamma \tau}{2}\right) (945 \exp(-4\gamma \tau) - \\ &- 250 \exp(-2\gamma \tau) + 1); \\ \frac{\partial^2 P_3^{(-1/2,0)}(\tau, \gamma)}{\partial \tau^2} &= -\frac{\gamma^2}{64} \exp\left(-\frac{\gamma \tau}{2}\right) (39039 \exp(-6\gamma \tau) - \\ &- 25515 \exp(-4\gamma \tau) + 2625 \exp(-2\gamma \tau) - 5); \\ \frac{\partial^2 P_4^{(-1/2,0)}(\tau, \gamma)}{\partial \tau^2} &= \frac{\gamma^2}{512} \exp\left(-\frac{\gamma \tau}{2}\right) (1859715 \exp(-8\gamma \tau) - \\ &- 2030028 \exp(-6\gamma \tau) + 561330 \exp(-4\gamma \tau) - 31500 \exp(-2\gamma \tau) + \\ &+ 35); \\ \frac{\partial^2 P_5^{(-1/2,0)}(\tau, \gamma)}{\partial \tau^2} &= -\frac{9\gamma^2}{1024} \exp\left(-\frac{\gamma \tau}{2}\right) (2263261 \exp(-10\gamma \tau) - \\ &- 3512795 \exp(-8\gamma \tau) + 1691690 \exp(-6\gamma \tau) - 270270 \times \\ &\times \exp(-4\gamma \tau) + 9625 \exp(-2\gamma \tau) - 7). \end{aligned}$$



Рис. 1.31. Вид 2-ой производной ортогональных функций Якоби 0-5 порядков;  $\gamma = 0,25$ ,  $c = 2$ ,  $\alpha = -1/2$ ,  $\beta = 0$

$$[1.32] \quad \frac{\partial^3 P_k^{(-1/2,0)}(\tau, \gamma)}{\partial \tau^3} = -\frac{\gamma^3}{8} \sum_{s=0}^k \binom{k}{s} \binom{k+s-1/2}{s-1/2} \times (-1)^s (4s+1)^3 \exp\left(-\frac{(4s+1)}{2} \gamma \tau\right).$$

Частные случаи для 3-ей производной функций 0-5 порядков:

$$\begin{aligned} \frac{\partial^3 P_0^{(-1/2,0)}(\tau, \gamma)}{\partial \tau^3} &= -\frac{\gamma^3}{8} \exp\left(-\frac{\gamma \tau}{2}\right); \\ \frac{\partial^3 P_1^{(-1/2,0)}(\tau, \gamma)}{\partial \tau^3} &= \frac{\gamma^3}{16} \exp\left(-\frac{\gamma \tau}{2}\right) (375 \exp(-2\gamma \tau) - 1); \\ \frac{\partial^3 P_2^{(-1/2,0)}(\tau, \gamma)}{\partial \tau^3} &= -\frac{\gamma^3}{64} \exp\left(-\frac{\gamma \tau}{2}\right) (25515 \exp(-4\gamma \tau) - \\ &- 1875 \exp(-2\gamma \tau) + 3); \\ \frac{\partial^3 P_3^{(-1/2,0)}(\tau, \gamma)}{\partial \tau^3} &= \frac{\gamma^3}{128} \exp\left(-\frac{\gamma \tau}{2}\right) (507507 \exp(-6\gamma \tau) - \\ &- 229635 \exp(-4\gamma \tau) + 13125 \exp(-2\gamma \tau) - 5); \end{aligned}$$

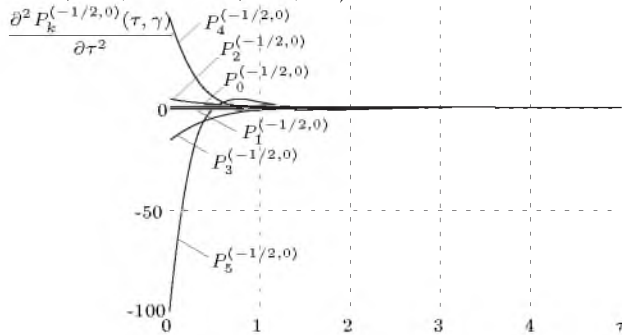
$$\begin{aligned} \frac{\partial^3 P_4^{(-1/2,0)}(\tau, \gamma)}{\partial \tau^3} &= -\frac{\gamma^3}{1024} \exp\left(-\frac{\gamma \tau}{2}\right) (31615155 \exp(-8\gamma \tau) - \\ &- 26390364 \exp(-6\gamma \tau) + 5051970 \exp(-4\gamma \tau) - 157500 \exp(-2\gamma \tau) + \\ &+ 35); \\ \frac{\partial^3 P_5^{(-1/2,0)}(\tau, \gamma)}{\partial \tau^3} &= \frac{9\gamma^3}{2048} \exp\left(-\frac{\gamma \tau}{2}\right) (47528481 \exp(-10\gamma \tau) - \\ &- 59717515 \exp(-8\gamma \tau) + 21991970 \exp(-6\gamma \tau) - 2432430 \times \\ &\times \exp(-4\gamma \tau) + 48125 \exp(-2\gamma \tau) - 7). \end{aligned}$$



Рис. 1.32. Вид 3-ей производной ортогональных функций Якоби 0-5 порядков;  $\gamma = 0,25$ ,  $c = 2$ ,  $\alpha = -1/2$ ,  $\beta = 0$

$$[1.33] \quad \frac{\partial^n P_k^{(-1/2,0)}(\tau, \gamma)}{\partial \tau^n} = \left(-\frac{\gamma}{2}\right)^n \sum_{s=0}^k \binom{k}{s} \times \binom{k+s-1/2}{s-1/2} (-1)^s (4s+1)^n \exp\left(-\frac{(4s+1)}{2} \gamma \tau\right).$$

Частные случаи для n-ой производной функций 0-5 порядков:

$$\begin{aligned} \frac{\partial^n P_0^{(-1/2,0)}(\tau, \gamma)}{\partial \tau^n} &= \left(-\frac{\gamma}{2}\right)^n \exp\left(-\frac{\gamma \tau}{2}\right); \\ \frac{\partial^n P_1^{(-1/2,0)}(\tau, \gamma)}{\partial \tau^n} &= -\frac{1}{2} \left(-\frac{\gamma}{2}\right)^n \exp\left(-\frac{\gamma \tau}{2}\right) (3 \cdot 5^n \times \\ &\times \exp(-2\gamma \tau) - 1); \\ \frac{\partial^n P_2^{(-1/2,0)}(\tau, \gamma)}{\partial \tau^n} &= \frac{1}{8} \left(-\frac{\gamma}{2}\right)^n \exp\left(-\frac{\gamma \tau}{2}\right) (35 \cdot 9^n \times \\ &\times \exp(-4\gamma \tau) - 30 \cdot 5^n \exp(-2\gamma \tau) + 3); \\ \frac{\partial^n P_3^{(-1/2,0)}(\tau, \gamma)}{\partial \tau^n} &= -\frac{1}{16} \left(-\frac{\gamma}{2}\right)^n \exp\left(-\frac{\gamma \tau}{2}\right) (231 \cdot 13^n \times \\ &\times \exp(-6\gamma \tau) - 315 \cdot 9^n \exp(-4\gamma \tau) + 105 \cdot 5^n \exp(-2\gamma \tau) - 5); \\ \frac{\partial^n P_4^{(-1/2,0)}(\tau, \gamma)}{\partial \tau^n} &= \frac{1}{128} \left(-\frac{\gamma}{2}\right)^n \exp\left(-\frac{\gamma \tau}{2}\right) (6435 \cdot 17^n \times \\ &\times \exp(-8\gamma \tau) - 12012 \cdot 13^n \exp(-6\gamma \tau) + 6930 \cdot 9^n \exp(-4\gamma \tau) - \\ &- 1260 \cdot 5^n \exp(-2\gamma \tau) + 35); \\ \frac{\partial^n P_5^{(-1/2,0)}(\tau, \gamma)}{\partial \tau^n} &= -\frac{1}{256} \left(-\frac{\gamma}{2}\right)^n \exp\left(-\frac{\gamma \tau}{2}\right) (46189 \cdot 21^n \times \\ &\times \exp(-10\gamma \tau) - 109395 \cdot 17^n \exp(-8\gamma \tau) + 90090 \cdot 13^n \times \\ &\times \exp(-6\gamma \tau) - 30030 \cdot 9^n \exp(-4\gamma \tau) + 3465 \cdot 5^n \exp(-2\gamma \tau) - 63). \end{aligned}$$

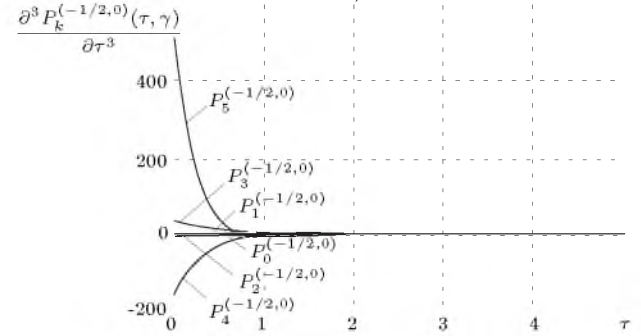

Рис. 1.33. Вид n-ой производной ортогональных функций Якоби 2-ого порядка;  $n = 0..5$ ,  $\gamma = 0, 25$ ,  $c = 2$ ,  $\alpha = -1/2$ ,  $\beta = 0$

$$[1.34] \quad \frac{\partial Leg_k(\tau, \gamma)}{\partial \tau} = -\gamma \sum_{s=0}^k \binom{k}{s} \binom{k+s}{s} (-1)^s \times (2s+1) \exp(-(2s+1)\gamma\tau).$$

Частные случаи для 1-ой производной функций 0-5 порядков:

$$\begin{aligned} \frac{\partial Leg_0(\tau, \gamma)}{\partial \tau} &= -\gamma \exp(-\gamma\tau); \\ \frac{\partial Leg_1(\tau, \gamma)}{\partial \tau} &= \gamma \exp(-\gamma\tau)(6 \exp(-2\gamma\tau) - 1); \\ \frac{\partial Leg_2(\tau, \gamma)}{\partial \tau} &= -\gamma \exp(-\gamma\tau)(30 \exp(-4\gamma\tau) - 18 \exp(-2\gamma\tau) + 1); \\ \frac{\partial Leg_3(\tau, \gamma)}{\partial \tau} &= \gamma \exp(-\gamma\tau)(140 \exp(-6\gamma\tau) - 150 \exp(-4\gamma\tau) + 36 \exp(-2\gamma\tau) - 1); \\ \frac{\partial Leg_4(\tau, \gamma)}{\partial \tau} &= -\gamma \exp(-\gamma\tau)(630 \exp(-8\gamma\tau) - 980 \times \\ &\times \exp(-6\gamma\tau) + 450 \exp(-4\gamma\tau) - 60 \exp(-2\gamma\tau) + 1); \\ \frac{\partial Leg_5(\tau, \gamma)}{\partial \tau} &= \gamma \exp(-\gamma\tau)(2772 \exp(-10\gamma\tau) - 5670 \times \\ &\times \exp(-8\gamma\tau) + 3920 \exp(-6\gamma\tau) - 1050 \exp(-4\gamma\tau) + 90 \times \\ &\times \exp(-2\gamma\tau) - 1). \end{aligned}$$

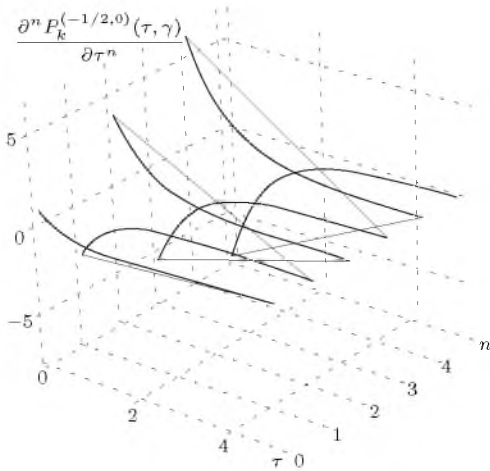

Рис. 1.34. Вид 1-ой производной ортогональных функций Лежандра 0-5 порядков;  $\gamma = 0, 25$ ,  $c = 2$

$$[1.35] \quad \frac{\partial^2 Leg_k(\tau, \gamma)}{\partial \tau^2} = \gamma^2 \sum_{s=0}^k \binom{k}{s} \binom{k+s}{s} (-1)^s \times (2s+1)^2 \exp(-(2s+1)\gamma\tau).$$

Частные случаи для 2-ой производной функций 0-5 порядков:

$$\begin{aligned} \frac{\partial^2 Leg_0(\tau, \gamma)}{\partial \tau^2} &= \gamma^2 \exp(-\gamma\tau); \\ \frac{\partial^2 Leg_1(\tau, \gamma)}{\partial \tau^2} &= -\gamma^2 \exp(-\gamma\tau)(18 \exp(-2\gamma\tau) - 1); \\ \frac{\partial^2 Leg_2(\tau, \gamma)}{\partial \tau^2} &= \gamma^2 \exp(-\gamma\tau)(150 \exp(-4\gamma\tau) - 54 \exp(-2\gamma\tau) + 1); \\ \frac{\partial^2 Leg_3(\tau, \gamma)}{\partial \tau^2} &= -\gamma^2 \exp(-\gamma\tau)(980 \exp(-6\gamma\tau) - 750 \times \\ &\times \exp(-4\gamma\tau) + 108 \exp(-2\gamma\tau) - 1); \\ \frac{\partial^2 Leg_4(\tau, \gamma)}{\partial \tau^2} &= \gamma^2 \exp(-\gamma\tau)(5670 \exp(-8\gamma\tau) - 6860 \times \\ &\times \exp(-6\gamma\tau) + 2250 \exp(-4\gamma\tau) - 180 \exp(-2\gamma\tau) + 1); \\ \frac{\partial^2 Leg_5(\tau, \gamma)}{\partial \tau^2} &= -\gamma^2 \exp(-\gamma\tau)(30492 \exp(-10\gamma\tau) - 51030 \times \\ &\times \exp(-8\gamma\tau) + 27440 \exp(-6\gamma\tau) - 5250 \exp(-4\gamma\tau) + \\ &+ 270 \exp(-2\gamma\tau) - 1). \end{aligned}$$

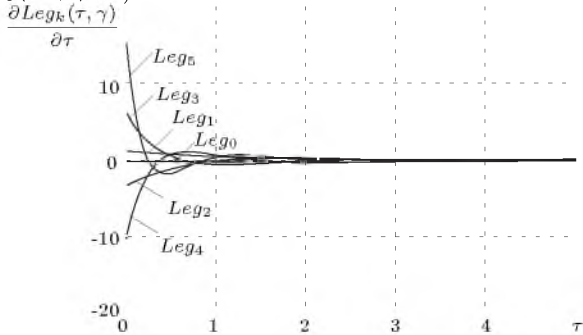

Рис. 1.35. Вид 2-ой производной ортогональных функций Лежандра 0-5 порядков;  $\gamma = 0, 25$ ,  $c = 2$

$$[1.36] \quad \frac{\partial^3 Leg_k(\tau, \gamma)}{\partial \tau^3} = -\gamma^3 \sum_{s=0}^k \binom{k}{s} \binom{k+s}{s} (-1)^s \times (2s+1)^3 \exp(-(2s+1)\gamma\tau).$$

Частные случаи для 3-ой производной функций 0-5 порядков:

$$\begin{aligned} \frac{\partial^3 Leg_0(\tau, \gamma)}{\partial \tau^3} &= -\gamma^3 \exp(-\gamma\tau); \\ \frac{\partial^3 Leg_1(\tau, \gamma)}{\partial \tau^3} &= \gamma^3 \exp(-\gamma\tau)(54 \exp(-2\gamma\tau) - 1); \\ \frac{\partial^3 Leg_2(\tau, \gamma)}{\partial \tau^3} &= -\gamma^3 \exp(-\gamma\tau)(750 \exp(-4\gamma\tau) - 162 \times \\ &\times \exp(-2\gamma\tau) + 1); \\ \frac{\partial^3 Leg_3(\tau, \gamma)}{\partial \tau^3} &= \gamma^3 \exp(-\gamma\tau)(6860 \exp(-6\gamma\tau) - 3750 \times \\ &\times \exp(-4\gamma\tau) + 324 \exp(-2\gamma\tau) - 1); \\ \frac{\partial^3 Leg_4(\tau, \gamma)}{\partial \tau^3} &= -\gamma^3 \exp(-\gamma\tau)(51030 \exp(-8\gamma\tau) - 48020 \times \\ &\times \exp(-6\gamma\tau) + 11250 \exp(-4\gamma\tau) - 540 \exp(-2\gamma\tau) + 1); \\ \frac{\partial^3 Leg_5(\tau, \gamma)}{\partial \tau^3} &= \gamma^3 \exp(-\gamma\tau)(335412 \exp(-10\gamma\tau) - 459270 \times \end{aligned}$$

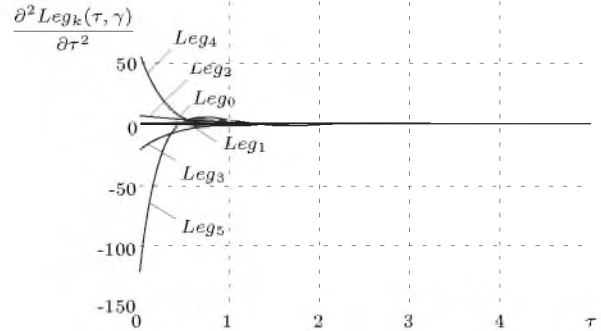

Рис. 1.36. Вид 3-ой производной ортогональных функций Лежандра 0-5 порядков;  $\gamma = 0, 25, c = 2$

$$[1.37] \quad \frac{\partial^n Leg_k(\tau, \gamma)}{\partial \tau^n} = (-\gamma)^n \sum_{s=0}^k \binom{k}{s} \binom{k+s}{s} (-1)^s \times \\ \times (2s+1)^n \exp(-(2s+1)\gamma\tau).$$

Частные случаи для n-ой производной функций 0-5 порядков:

$$\frac{\partial^n Leg_0(\tau, \gamma)}{\partial \tau^n} = (-\gamma)^n \exp(-\gamma\tau);$$

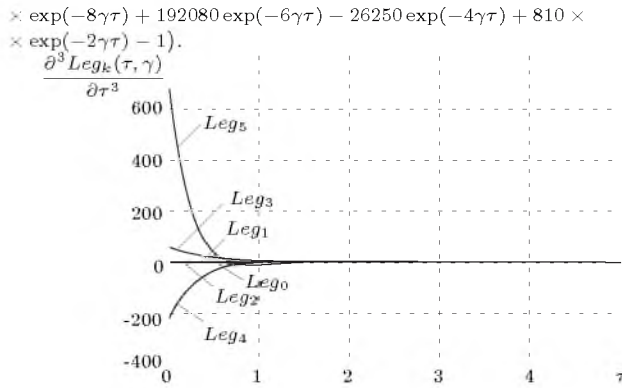
$$\frac{\partial^n Leg_1(\tau, \gamma)}{\partial \tau^n} = -(-\gamma)^n \exp(-\gamma\tau)(2 \cdot 3^n \exp(-2\gamma\tau) - 1);$$

$$\frac{\partial^n Leg_2(\tau, \gamma)}{\partial \tau^n} = (-\gamma)^n \exp(-\gamma\tau)(6 \cdot 5^n \exp(-4\gamma\tau) - 6 \cdot 3^n \times \\ \times \exp(-2\gamma\tau) + 1);$$

$$\frac{\partial^n Leg_3(\tau, \gamma)}{\partial \tau^n} = -(-\gamma)^n \exp(-\gamma\tau)(20 \cdot 7^n \exp(-6\gamma\tau) - \\ - 30 \cdot 5^n \exp(-4\gamma\tau) + 12 \cdot 3^n \exp(-2\gamma\tau) - 1);$$

$$\frac{\partial^n Leg_4(\tau, \gamma)}{\partial \tau^n} = (-\gamma)^n \exp(-\gamma\tau)(70 \cdot 9^n \exp(-8\gamma\tau) - 140 \cdot 7^n \times \\ \times \exp(-6\gamma\tau) + 90 \cdot 5^n \exp(-4\gamma\tau) - 20 \cdot 3^n \exp(-2\gamma\tau) + 1);$$

$$\frac{\partial^n Leg_5(\tau, \gamma)}{\partial \tau^n} = -(-\gamma)^n \exp(-\gamma\tau)(252 \cdot 11^n \exp(-10\gamma\tau) - \\ - 630 \cdot 9^n \exp(-8\gamma\tau) + 560 \cdot 7^n \exp(-6\gamma\tau) - 210 \cdot 5^n \exp(-4\gamma\tau) + \\ + 30 \cdot 3^n \exp(-2\gamma\tau) - 1).$$



Рис. 1.37. Вид n-ой производной ортогональных функций Лежандра 2-ого порядка;  $n = 0..5, \gamma = 0, 25, c = 2$

$$[1.38] \quad \frac{\partial P_k^{(1/2,0)}(\tau, \gamma)}{\partial \tau} = -\frac{\gamma}{2} \sum_{s=0}^k \binom{k}{s} \binom{k+s+1/2}{s+1/2} \times \\ \times (-1)^s (4s+3) \exp\left(-\frac{(4s+3)\gamma\tau}{2}\right).$$

Частные случаи для 1-ой производной функций 0-5 порядков:

$$\frac{\partial P_0^{(1/2,0)}(\tau, \gamma)}{\partial \tau} = -\frac{3\gamma}{2} \exp\left(-\frac{3\gamma\tau}{2}\right);$$

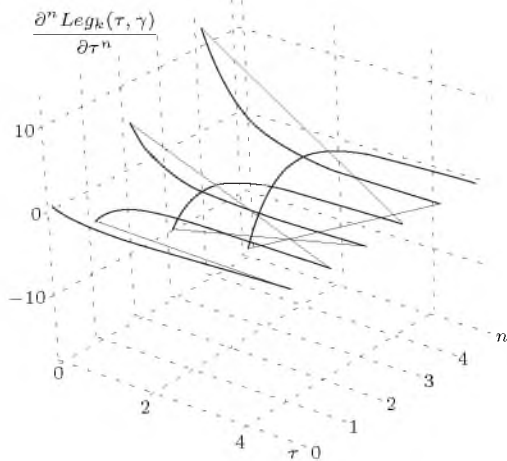
$$\frac{\partial P_1^{(1/2,0)}(\tau, \gamma)}{\partial \tau} = \frac{\gamma}{4} \exp\left(-\frac{3\gamma\tau}{2}\right)(35 \exp(-2\gamma\tau) - 9);$$

$$\frac{\partial P_2^{(1/2,0)}(\tau, \gamma)}{\partial \tau} = -\frac{\gamma}{16} \exp\left(-\frac{3\gamma\tau}{2}\right)(693 \exp(-4\gamma\tau) - 490 \times \\ \times \exp(-2\gamma\tau) + 45);$$

$$\frac{\partial P_3^{(1/2,0)}(\tau, \gamma)}{\partial \tau} = \frac{\gamma}{32} \exp\left(-\frac{3\gamma\tau}{2}\right)(6435 \exp(-6\gamma\tau) - 7623 \times \\ \times \exp(-4\gamma\tau) + 2205 \exp(-2\gamma\tau) - 105);$$

$$\frac{\partial P_4^{(1/2,0)}(\tau, \gamma)}{\partial \tau} = -\frac{\gamma}{256} \exp\left(-\frac{3\gamma\tau}{2}\right)(230945 \exp(-8\gamma\tau) - \\ - 386100 \exp(-6\gamma\tau) + 198198 \exp(-4\gamma\tau) - 32340 \exp(-2\gamma\tau) + \\ + 945);$$

$$\frac{\partial P_5^{(1/2,0)}(\tau, \gamma)}{\partial \tau} = \frac{\gamma}{512} \exp\left(-\frac{3\gamma\tau}{2}\right)(2028117 \exp(-10\gamma\tau) - \\ - 4387955 \times \exp(-8\gamma\tau) + 3281850 \exp(-6\gamma\tau) - 990990 \times \\ \times \exp(-4\gamma\tau) + 105105 \exp(-2\gamma\tau) - 2079).$$

Рис. 1.38. Вид 1-ой производной ортогональных функций Якоби 0-5 порядков;  $\gamma = 0, 25, c = 2, \alpha = 1/2, \beta = 0$

$$[1.39] \quad \frac{\partial^2 P_k^{(1/2,0)}(\tau, \gamma)}{\partial \tau^2} = \frac{\gamma^2}{4} \sum_{s=0}^k \binom{k}{s} \binom{k+s+1/2}{s+1/2} \times \\ \times (-1)^s (4s+3)^2 \exp\left(-\frac{(4s+3)\gamma\tau}{2}\right).$$

Частные случаи для 2-ой производной функций 0-5 порядков:

$$\frac{\partial^2 P_0^{(1/2,0)}(\tau, \gamma)}{\partial \tau^2} = \frac{9\gamma^2}{4} \exp\left(-\frac{3\gamma\tau}{2}\right);$$

$$\frac{\partial^2 P_1^{(1/2,0)}(\tau, \gamma)}{\partial \tau^2} = -\frac{\gamma^2}{8} \exp\left(-\frac{3\gamma\tau}{2}\right)(245 \exp(-2\gamma\tau) - 27);$$

$$\frac{\partial^2 P_2^{(1/2,0)}(\tau, \gamma)}{\partial \tau^2} = \frac{\gamma^2}{32} \exp\left(-\frac{3\gamma\tau}{2}\right)(7623 \exp(-4\gamma\tau) - 3430 \times \\ \times \exp(-2\gamma\tau) + 135);$$

$$\frac{\partial^2 P_3^{(1/2,0)}(\tau, \gamma)}{\partial \tau^2} = -\frac{\gamma^2}{64} \exp\left(-\frac{3\gamma\tau}{2}\right)(96525 \exp(-6\gamma\tau) - \\ - 83853 \exp(-4\gamma\tau) + 15435 \exp(-2\gamma\tau) - 315);$$



Рис. 1.39. Вид 2-ой производной ортогональных функций Якоби 0-5 порядков;  $\gamma = 0,25$ ,  $c = 2$ ,  $\alpha = 1/2$ ,  $\beta = 0$

$$[1.40] \quad \frac{\partial^3 P_k^{(1/2,0)}(\tau, \gamma)}{\partial \tau^3} = -\frac{\gamma^3}{8} \sum_{s=0}^k \binom{k}{s} \binom{k+s+1/2}{s+1/2} \times (-1)^s (4s+3)^3 \exp\left(-\frac{(4s+3)}{2} \gamma \tau\right).$$

Частные случаи для 3-ой производной функций 0-5 порядков:

$$\frac{\partial^3 P_0^{(1/2,0)}(\tau, \gamma)}{\partial \tau^3} = -\frac{27\gamma^3}{8} \exp\left(-\frac{3\gamma\tau}{2}\right);$$

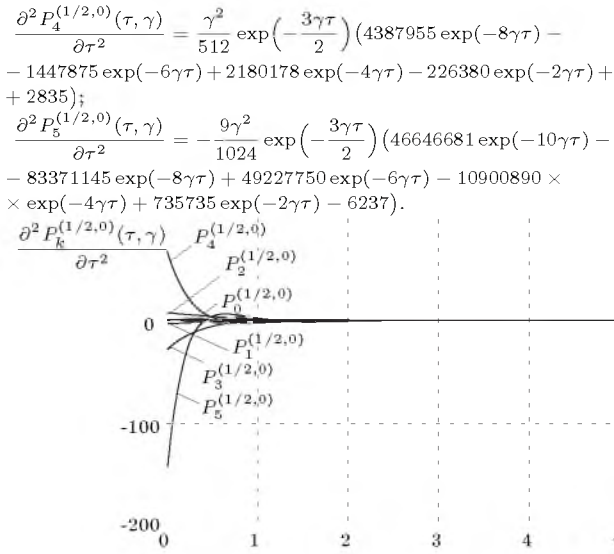
$$\frac{\partial^3 P_1^{(1/2,0)}(\tau, \gamma)}{\partial \tau^3} = \frac{\gamma^3}{16} \exp\left(-\frac{3\gamma\tau}{2}\right) (1715 \exp(-2\gamma\tau) - 81);$$

$$\frac{\partial^3 P_2^{(1/2,0)}(\tau, \gamma)}{\partial \tau^3} = -\frac{\gamma^3}{64} \exp\left(-\frac{3\gamma\tau}{2}\right) (83853 \exp(-4\gamma\tau) - 24010 \exp(-2\gamma\tau) + 405);$$

$$\frac{\partial^3 P_3^{(1/2,0)}(\tau, \gamma)}{\partial \tau^3} = \frac{\gamma^3}{128} \exp\left(-\frac{3\gamma\tau}{2}\right) (1447875 \exp(-6\gamma\tau) - 922383 \exp(-4\gamma\tau) + 108045 \exp(-2\gamma\tau) - 945);$$

$$\frac{\partial^3 P_4^{(1/2,0)}(\tau, \gamma)}{\partial \tau^3} = -\frac{\gamma^3}{1024} \exp\left(-\frac{3\gamma\tau}{2}\right) (83371145 \times \exp(-8\gamma\tau) - 86872500 \exp(-6\gamma\tau) + 23981958 \exp(-4\gamma\tau) - 1584660 \exp(-2\gamma\tau) + 8505);$$

$$\frac{\partial^3 P_5^{(1/2,0)}(\tau, \gamma)}{\partial \tau^3} = \frac{9\gamma^3}{2048} \exp\left(-\frac{3\gamma\tau}{2}\right) (1072873893 \times \exp(-10\gamma\tau) - 1584051755 \exp(-8\gamma\tau) + 738416250 \times \exp(-6\gamma\tau) - 119909790 \exp(-4\gamma\tau) + 5150145 \exp(-2\gamma\tau) - 18711).$$



Рис. 1.40. Вид 3-ей производной ортогональных функций Якоби 0-5 порядков;  $\gamma = 0,25$ ,  $c = 2$ ,  $\alpha = 1/2$ ,  $\beta = 0$

$$[1.41] \quad \frac{\partial^n P_k^{(1/2,0)}(\tau, \gamma)}{\partial \tau^n} = \left(-\frac{\gamma}{2}\right)^n \sum_{s=0}^k \binom{k}{s} \times \binom{k+s+1/2}{s+1/2} (-1)^s (4s+3)^n \exp\left(-\frac{(4s+3)}{2} \gamma \tau\right).$$

Частные случаи для n-ой производной функций 0-5 порядков:

$$\frac{\partial^n P_0^{(1/2,0)}(\tau, \gamma)}{\partial \tau^n} = 3^n \left(-\frac{\gamma}{2}\right)^n \exp\left(-\frac{3\gamma\tau}{2}\right);$$

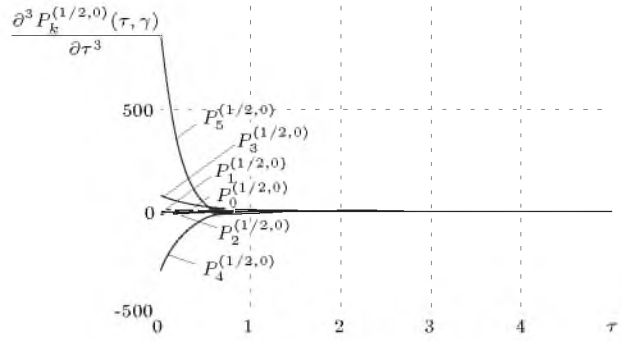
$$\frac{\partial^n P_1^{(1/2,0)}(\tau, \gamma)}{\partial \tau^n} = -\frac{1}{2} \left(-\frac{\gamma}{2}\right)^n \exp\left(-\frac{3\gamma\tau}{2}\right) (5 \cdot 7^n \exp(-2\gamma\tau) - 3 \cdot 3^n);$$

$$\frac{\partial^n P_2^{(1/2,0)}(\tau, \gamma)}{\partial \tau^n} = \frac{1}{8} \left(-\frac{\gamma}{2}\right)^n \exp\left(-\frac{3\gamma\tau}{2}\right) (63 \cdot 11^n \exp(-4\gamma\tau) - 70 \cdot 7^n \exp(-2\gamma\tau) + 15 \cdot 3^n);$$

$$\frac{\partial^n P_3^{(1/2,0)}(\tau, \gamma)}{\partial \tau^n} = -\frac{1}{16} \left(-\frac{\gamma}{2}\right)^n \exp\left(-\frac{3\gamma\tau}{2}\right) (429 \cdot 15^n \times \exp(-6\gamma\tau) - 693 \cdot 11^n \exp(-4\gamma\tau) + 315 \cdot 7^n \exp(-2\gamma\tau) - 35 \cdot 3^n);$$

$$\frac{\partial^n P_4^{(1/2,0)}(\tau, \gamma)}{\partial \tau^n} = \frac{1}{128} \left(-\frac{\gamma}{2}\right)^n \exp\left(-\frac{3\gamma\tau}{2}\right) (12155 \cdot 19^n \times \exp(-8\gamma\tau) - 25740 \cdot 15^n \exp(-6\gamma\tau) + 18018 \cdot 11^n \exp(-4\gamma\tau) - 4620 \cdot 7^n \exp(-2\gamma\tau) + 315 \cdot 3^n);$$

$$\frac{\partial^n P_5^{(1/2,0)}(\tau, \gamma)}{\partial \tau^n} = -\frac{1}{256} \left(-\frac{\gamma}{2}\right)^n \exp\left(-\frac{3\gamma\tau}{2}\right) (88179 \cdot 23^n \times \exp(-10\gamma\tau) - 230945 \cdot 19^n \exp(-8\gamma\tau) + 218790 \cdot 15^n \times \exp(-6\gamma\tau) - 90090 \cdot 11^n \exp(-4\gamma\tau) + 15015 \cdot 7^n \exp(-2\gamma\tau) - 693 \cdot 3^n).$$



Рис. 1.41. Вид n-ой производной ортогональных функций Якоби 2-ого порядка;  $n = 0..5$ ,  $\gamma = 0,25$ ,  $c = 2$ ,  $\alpha = 1/2$ ,  $\beta = 0$

$$[1.42] \quad \frac{\partial P_k^{(1,0)}(\tau, \gamma)}{\partial \tau} = -\gamma \sum_{s=0}^k \binom{k}{s} \binom{k+s+1}{s+1} (-1)^s \times (s+1) \exp(-(s+1)\gamma\tau).$$

Частные случаи для 1-ой производной функций 0-5 порядков:

$$\begin{aligned} \frac{\partial P_0^{(1,0)}(\tau, \gamma)}{\partial \tau} &= -\gamma \exp(-\gamma\tau); \\ \frac{\partial P_1^{(1,0)}(\tau, \gamma)}{\partial \tau} &= 2\gamma \exp(-\gamma\tau)(3 \exp(-\gamma\tau) - 1); \\ \frac{\partial P_2^{(1,0)}(\tau, \gamma)}{\partial \tau} &= -3\gamma \exp(-\gamma\tau)(10 \exp(-2\gamma\tau) - 8 \exp(-\gamma\tau) + 1); \\ \frac{\partial P_3^{(1,0)}(\tau, \gamma)}{\partial \tau} &= 4\gamma \exp(-\gamma\tau)(35 \exp(-3\gamma\tau) - 45 \exp(-2\gamma\tau) + 15 \exp(-\gamma\tau) - 1); \\ \frac{\partial P_4^{(1,0)}(\tau, \gamma)}{\partial \tau} &= -5\gamma \exp(-\gamma\tau)(126 \exp(-4\gamma\tau) - 224 \times \\ &\times \exp(-3\gamma\tau) + 126 \exp(-2\gamma\tau) - 24 \exp(-\gamma\tau) + 1); \\ \frac{\partial P_5^{(1,0)}(\tau, \gamma)}{\partial \tau} &= 6\gamma \exp(-\gamma\tau)(462 \exp(-5\gamma\tau) - 1050 \times \\ &\times \exp(-4\gamma\tau) + 840 \exp(-3\gamma\tau) - 280 \exp(-2\gamma\tau) + 210 \times \\ &\times \exp(-\gamma\tau) - 1). \end{aligned}$$

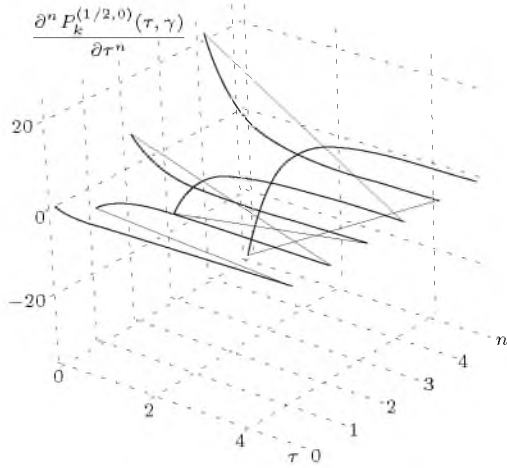

Рис. 1.42. Вид 1-ой производной ортогональных функций Якоби 0-5 порядков;  $\gamma = 0,25$ ,  $c = 1$ ,  $\alpha = 1$ ,  $\beta = 0$

$$[1.43] \quad \frac{\partial^2 P_k^{(1,0)}(\tau, \gamma)}{\partial \tau^2} = \gamma^2 \sum_{s=0}^k \binom{k}{s} \binom{k+s+1}{s+1} (-1)^s \times (s+1)^2 \exp(-(s+1)\gamma\tau).$$

Частные случаи для 2-ой производной функций 0-5 порядков:

$$\begin{aligned} \frac{\partial^2 P_0^{(1,0)}(\tau, \gamma)}{\partial \tau^2} &= \gamma^2 \exp(-\gamma\tau); \\ \frac{\partial^2 P_1^{(1,0)}(\tau, \gamma)}{\partial \tau^2} &= -2\gamma^2 \exp(-\gamma\tau)(6 \exp(-\gamma\tau) - 1); \\ \frac{\partial^2 P_2^{(1,0)}(\tau, \gamma)}{\partial \tau^2} &= 3\gamma^2 \exp(-\gamma\tau)(30 \exp(-2\gamma\tau) - 16 \exp(-\gamma\tau) + 1); \\ \frac{\partial^2 P_3^{(1,0)}(\tau, \gamma)}{\partial \tau^2} &= -4\gamma^2 \exp(-\gamma\tau)(140 \exp(-3\gamma\tau) - 135 \times \\ &\times \exp(-2\gamma\tau) + 30 \exp(-\gamma\tau) - 1); \\ \frac{\partial^2 P_4^{(1,0)}(\tau, \gamma)}{\partial \tau^2} &= 5\gamma^2 \exp(-\gamma\tau)(630 \exp(-4\gamma\tau) - 896 \times \\ &\times \exp(-3\gamma\tau) + 378 \exp(-2\gamma\tau) - 48 \exp(-\gamma\tau) + 1); \\ \frac{\partial^2 P_5^{(1,0)}(\tau, \gamma)}{\partial \tau^2} &= -6\gamma^2 \exp(-\gamma\tau)(2772 \exp(-5\gamma\tau) - 5250 \times \\ &\times \exp(-4\gamma\tau) + 3360 \exp(-3\gamma\tau) - 840 \exp(-2\gamma\tau) + 70 \times \\ &\times \exp(-\gamma\tau) - 1). \end{aligned}$$

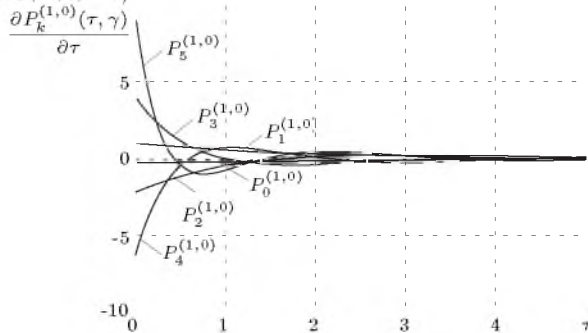

Рис. 1.43. Вид 2-ой производной ортогональных функций Якоби 0-5 порядков;  $\gamma = 0,25$ ,  $c = 1$ ,  $\alpha = 1$ ,  $\beta = 0$

$$[1.44] \quad \frac{\partial^3 P_k^{(1,0)}(\tau, \gamma)}{\partial \tau^3} = -\gamma^3 \sum_{s=0}^k \binom{k}{s} \binom{k+s+1}{s+1} (-1)^s \times (s+1)^3 \exp(-(s+1)\gamma\tau).$$

Частные случаи для 3-ой производной функций 0-5 порядков:

$$\begin{aligned} \frac{\partial^3 P_0^{(1,0)}(\tau, \gamma)}{\partial \tau^3} &= -\gamma^3 \exp(-\gamma\tau); \\ \frac{\partial^3 P_1^{(1,0)}(\tau, \gamma)}{\partial \tau^3} &= 2\gamma^3 \exp(-\gamma\tau)(12 \exp(-\gamma\tau) - 1); \\ \frac{\partial^3 P_2^{(1,0)}(\tau, \gamma)}{\partial \tau^3} &= -3\gamma^3 \exp(-\gamma\tau)(90 \exp(-2\gamma\tau) - 32 \times \\ &\times \exp(-\gamma\tau) + 1); \\ \frac{\partial^3 P_3^{(1,0)}(\tau, \gamma)}{\partial \tau^3} &= 4\gamma^3 \exp(-\gamma\tau)(560 \exp(-3\gamma\tau) - 405 \times \\ &\times \exp(-2\gamma\tau) + 60 \exp(-\gamma\tau) - 1); \\ \frac{\partial^3 P_4^{(1,0)}(\tau, \gamma)}{\partial \tau^3} &= -5\gamma^3 \exp(-\gamma\tau)(3150 \exp(-4\gamma\tau) - 3584 \times \\ &\times \exp(-3\gamma\tau) + 1134 \exp(-2\gamma\tau) - 96 \exp(-\gamma\tau) + 1); \end{aligned}$$

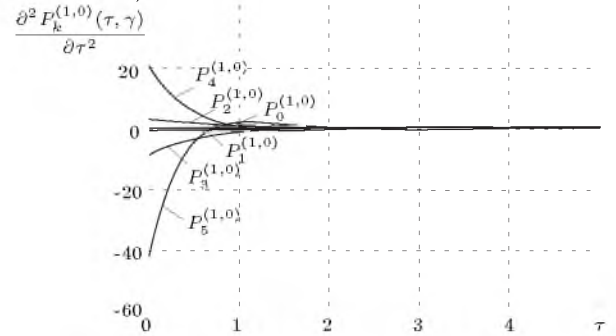
$$\frac{\partial^3 P_5^{(1,0)}(\tau, \gamma)}{\partial \tau^3} = 6\gamma^3 \exp(-\gamma\tau) (16632 \exp(-5\gamma\tau) - 26250 \times$$

$$\times \exp(-4\gamma\tau) + 13440 \exp(-3\gamma\tau) - 2520 \exp(-2\gamma\tau) + 140 \times$$

$$\times \exp(-\gamma\tau) - 1).$$



Рис. 1.44. Вид 3-ой производной ортогональных функций Якоби 0-5 порядков;  $\gamma = 0,25$ ,  $c = 1$ ,  $\alpha = 1$ ,  $\beta = 0$

$$[1.45] \quad \frac{\partial^n P_k^{(1,0)}(\tau, \gamma)}{\partial \tau^n} = (-\gamma)^n \sum_{s=0}^k \binom{k}{s} \binom{k+s+1}{s+1} \times$$

$$\times (-1)^s (s+1)^n \exp(-(s+1)\gamma\tau).$$

Частные случаи для n-ой производной функций 0-5 порядков:

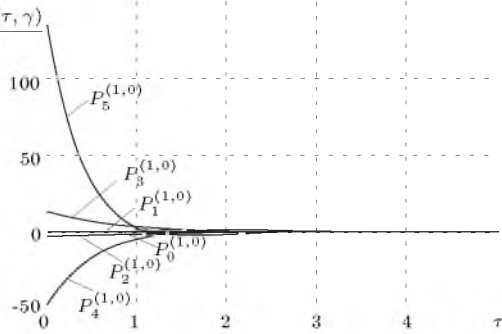
$$\frac{\partial^n P_0^{(1,0)}(\tau, \gamma)}{\partial \tau^n} = (-\gamma)^n \exp(-\gamma\tau);$$

$$\frac{\partial^n P_1^{(1,0)}(\tau, \gamma)}{\partial \tau^n} = -(-\gamma)^n \exp(-\gamma\tau) (3 \cdot 2^n \exp(-\gamma\tau) - 2);$$

$$\frac{\partial^n P_2^{(1,0)}(\tau, \gamma)}{\partial \tau^n} = (-\gamma)^n \exp(-\gamma\tau) (10 \cdot 3^n \exp(-2\gamma\tau) - 12 \cdot 2^n \times$$

$$\times \exp(-\gamma\tau) + 3);$$

$$\frac{\partial^n P_3^{(1,0)}(\tau, \gamma)}{\partial \tau^n} = -(-\gamma)^n \exp(-\gamma\tau) (35 \cdot 4^n \exp(-3\gamma\tau) -$$

$$- 60 \cdot 3^n \exp(-2\gamma\tau) + 30 \cdot 2^n \exp(-\gamma\tau) - 4);$$

$$\frac{\partial^n P_4^{(1,0)}(\tau, \gamma)}{\partial \tau^n} = (-\gamma)^n \exp(-\gamma\tau) (126 \cdot 5^n \exp(-4\gamma\tau) -$$

$$- 280 \cdot 4^n \exp(-3\gamma\tau) + 210 \cdot 3^n \exp(-2\gamma\tau) - 60 \cdot 2^n \exp(-\gamma\tau) +$$

$$+ 5);$$

$$\frac{\partial^n P_5^{(1,0)}(\tau, \gamma)}{\partial \tau^n} = -(-\gamma)^n \exp(-\gamma\tau) (462 \cdot 6^n \exp(-5\gamma\tau) -$$

$$- 1260 \cdot 5^n \exp(-4\gamma\tau) + 1260 \cdot 4^n \exp(-3\gamma\tau) - 560 \cdot 3^n \times$$

$$\times \exp(-2\gamma\tau) + 105 \cdot 2^n \exp(-\gamma\tau) - 1).$$



Рис. 1.45. Вид n-ой производной ортогональных функций Якоби 2-ого порядка;  $n = 0..5$ ,  $\gamma = 0,25$ ,  $c = 1$ ,  $\alpha = 1$ ,  $\beta = 0$

$$[1.46] \quad \frac{\partial P_k^{(2,0)}(\tau, \gamma)}{\partial \tau} = -\gamma \sum_{s=0}^k \binom{k}{s} \binom{k+s+2}{s+2} (-1)^s \times$$

$$\times (2s+3) \exp(-(2s+3)\gamma\tau).$$

Частные случаи для 1-ой производной функций 0-5 порядков:

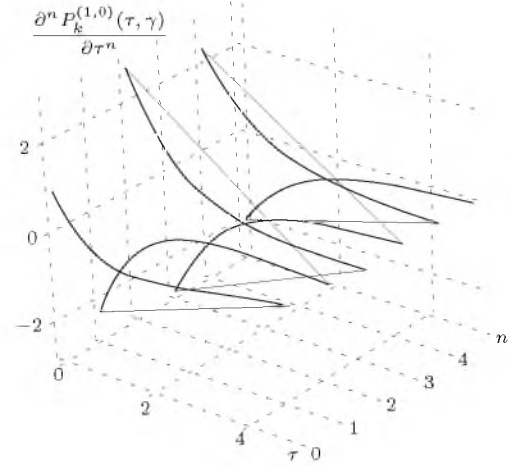
$$\frac{\partial P_0^{(2,0)}(\tau, \gamma)}{\partial \tau} = -3\gamma \exp(-3\gamma\tau);$$

$$\frac{\partial P_1^{(2,0)}(\tau, \gamma)}{\partial \tau} = \gamma \exp(-3\gamma\tau) (20 \exp(-2\gamma\tau) - 9);$$

$$\frac{\partial P_2^{(2,0)}(\tau, \gamma)}{\partial \tau} = -\gamma \exp(-3\gamma\tau) (105 \exp(-4\gamma\tau) - 100 \times$$

$$\times \exp(-2\gamma\tau) + 18);$$

$$\frac{\partial P_3^{(2,0)}(\tau, \gamma)}{\partial \tau} = \gamma \exp(-3\gamma\tau) (504 \exp(-6\gamma\tau) - 735 \times$$

$$\times \exp(-4\gamma\tau) + 300 \exp(-2\gamma\tau) - 30);$$

$$\frac{\partial P_4^{(2,0)}(\tau, \gamma)}{\partial \tau} = -\gamma \exp(-3\gamma\tau) (2310 \exp(-8\gamma\tau) - 4536 \times$$

$$\times \exp(-6\gamma\tau) + 2940 \exp(-4\gamma\tau) - 700 \exp(-2\gamma\tau) + 45);$$

$$\frac{\partial P_5^{(2,0)}(\tau, \gamma)}{\partial \tau} = \gamma \exp(-3\gamma\tau) (10296 \exp(-10\gamma\tau) - 25410 \times$$

$$\times \exp(-8\gamma\tau) + 22680 \exp(-6\gamma\tau) - 8820 \exp(-4\gamma\tau) + 1400 \times$$

$$\times \exp(-2\gamma\tau) - 63).$$



Рис. 1.46. Вид 1-ой производной ортогональных функций Якоби 0-5 порядков;  $\gamma = 0,25$ ,  $c = 2$ ,  $\alpha = 2$ ,  $\beta = 0$

$$[1.47] \quad \frac{\partial^2 P_k^{(2,0)}(\tau, \gamma)}{\partial \tau^2} = \gamma^2 \sum_{s=0}^k \binom{k}{s} \binom{k+s+2}{s+2} (-1)^s \times \\ \times (2s+3)^2 \exp(-(2s+3)\gamma\tau).$$

Частные случаи для 2-ой производной функций 0-5 порядков:

$$\frac{\partial^2 P_0^{(2,0)}(\tau, \gamma)}{\partial \tau^2} = 9\gamma^2 \exp(-3\gamma\tau);$$

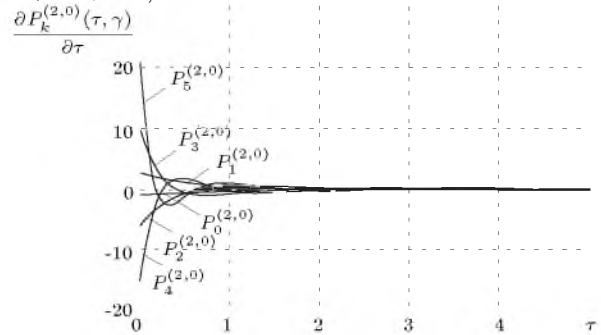
$$\frac{\partial^2 P_1^{(2,0)}(\tau, \gamma)}{\partial \tau^2} = -\gamma^2 \exp(-3\gamma\tau)(100 \exp(-2\gamma\tau) - 27);$$

$$\frac{\partial^2 P_2^{(2,0)}(\tau, \gamma)}{\partial \tau^2} = \gamma^2 \exp(-3\gamma\tau)(735 \exp(-4\gamma\tau) - 500 \times \\ \times \exp(-2\gamma\tau) + 54);$$

$$\frac{\partial^2 P_3^{(2,0)}(\tau, \gamma)}{\partial \tau^2} = -\gamma^2 \exp(-3\gamma\tau)(4536 \exp(-6\gamma\tau) - 5145 \times \\ \times \exp(-4\gamma\tau) + 1500 \exp(-2\gamma\tau) - 90);$$

$$\frac{\partial^2 P_4^{(2,0)}(\tau, \gamma)}{\partial \tau^2} = \gamma^2 \exp(-3\gamma\tau)(25410 \exp(-8\gamma\tau) - 40824 \times \\ \times \exp(-6\gamma\tau) + 20580 \exp(-4\gamma\tau) - 3500 \exp(-2\gamma\tau) + 135);$$

$$\frac{\partial^2 P_5^{(2,0)}(\tau, \gamma)}{\partial \tau^2} = -\gamma^2 \exp(-3\gamma\tau)(133848 \exp(-10\gamma\tau) - \\ - 279510 \exp(-8\gamma\tau) + 204120 \exp(-6\gamma\tau) - 61740 \times \\ \times \exp(-4\gamma\tau) + 7000 \exp(-2\gamma\tau) - 189).$$



Рис. 1.47. Вид 2-ой производной ортогональных функций Якоби 0-5 порядков;  $\gamma = 0, 25$ ,  $c = 2$ ,  $\alpha = 2$ ,  $\beta = 0$

$$[1.48] \quad \frac{\partial^3 P_k^{(2,0)}(\tau, \gamma)}{\partial \tau^3} = -\gamma^3 \sum_{s=0}^k \binom{k}{s} \binom{k+s+2}{s+2} (-1)^s \times \\ \times (2s+3)^3 \exp(-(2s+3)\gamma\tau).$$

Частные случаи для 3-ой производной функций 0-5 порядков:

$$\frac{\partial^3 P_0^{(2,0)}(\tau, \gamma)}{\partial \tau^3} = -27\gamma^3 \exp(-3\gamma\tau);$$

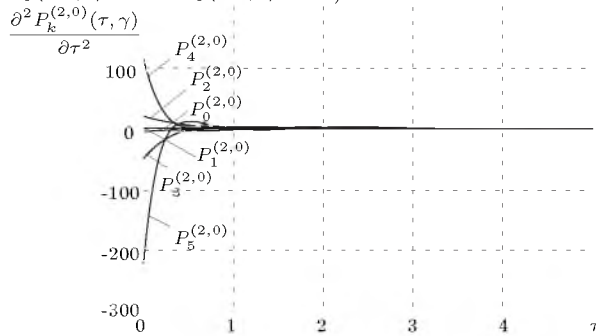
$$\frac{\partial^3 P_1^{(2,0)}(\tau, \gamma)}{\partial \tau^3} = \gamma^3 \exp(-3\gamma\tau)(500 \exp(-2\gamma\tau) - 81);$$

$$\frac{\partial^3 P_2^{(2,0)}(\tau, \gamma)}{\partial \tau^3} = -\gamma^3 \exp(-3\gamma\tau)(5145 \exp(-4\gamma\tau) - 2500 \times \\ \times \exp(-2\gamma\tau) + 162);$$

$$\frac{\partial^3 P_3^{(2,0)}(\tau, \gamma)}{\partial \tau^3} = \gamma^3 \exp(-3\gamma\tau)(40824 \exp(-6\gamma\tau) - 36015 \times \\ \times \exp(-4\gamma\tau) + 7500 \exp(-2\gamma\tau) - 270);$$

$$\frac{\partial^3 P_4^{(2,0)}(\tau, \gamma)}{\partial \tau^3} = -\gamma^3 \exp(-3\gamma\tau)(279510 \exp(-8\gamma\tau) - \\ - 367416 \exp(-6\gamma\tau) + 144060 \exp(-4\gamma\tau) - 17500 \exp(-2\gamma\tau) +$$

$$+ 405);$$

$$\frac{\partial^3 P_5^{(2,0)}(\tau, \gamma)}{\partial \tau^3} = \gamma^3 \exp(-3\gamma\tau)(1740024 \exp(-10\gamma\tau) - \\ - 3074610 \exp(-8\gamma\tau) + 1837080 \exp(-6\gamma\tau) - 432180 \times \\ \times \exp(-4\gamma\tau) + 35000 \exp(-2\gamma\tau) - 567).$$



Рис. 1.48. Вид 3-ой производной ортогональных функций Якоби 0-5 порядков;  $\gamma = 0, 25$ ,  $c = 2$ ,  $\alpha = 2$ ,  $\beta = 0$

$$[1.49] \quad \frac{\partial^n P_k^{(2,0)}(\tau, \gamma)}{\partial \tau^n} = (-\gamma)^n \sum_{s=0}^k \binom{k}{s} \binom{k+s+2}{s+2} \times \\ \times (-1)^s (2s+3)^n \exp(-(2s+3)\gamma\tau).$$

Частные случаи для n-ой производной функций 0-5 порядков:

$$\frac{\partial^n P_0^{(2,0)}(\tau, \gamma)}{\partial \tau^n} = (-3\gamma)^n \exp(-3\gamma\tau);$$

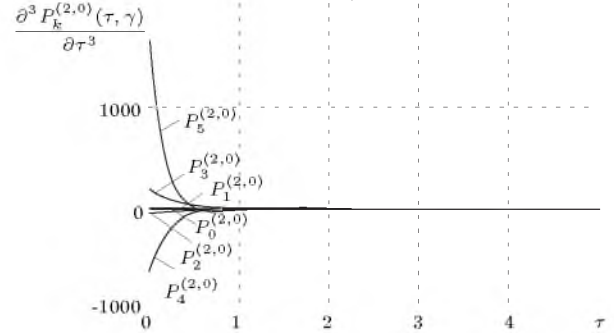
$$\frac{\partial^n P_1^{(2,0)}(\tau, \gamma)}{\partial \tau^n} = -(-\gamma)^n \exp(-3\gamma\tau)(4 \cdot 5^n \exp(-2\gamma\tau) - \\ - 3 \cdot 3^n);$$

$$\frac{\partial^n P_2^{(2,0)}(\tau, \gamma)}{\partial \tau^n} = (-\gamma)^n \exp(-3\gamma\tau)(15 \cdot 7^n \exp(-4\gamma\tau) - \\ - 20 \cdot 5^n \exp(-2\gamma\tau) + 6 \cdot 3^n);$$

$$\frac{\partial^n P_3^{(2,0)}(\tau, \gamma)}{\partial \tau^n} = -(-\gamma)^n \exp(-3\gamma\tau)(56 \cdot 9^n \exp(-6\gamma\tau) - \\ - 105 \cdot 7^n \exp(-4\gamma\tau) + 60 \cdot 5^n \exp(-2\gamma\tau) - 10 \cdot 3^n);$$

$$\frac{\partial^n P_4^{(2,0)}(\tau, \gamma)}{\partial \tau^n} = (-\gamma)^n \exp(-3\gamma\tau)(210 \cdot 11^n \exp(-8\gamma\tau) - \\ - 504 \cdot 9^n \exp(-6\gamma\tau) + 420 \cdot 7^n \exp(-4\gamma\tau) - 140 \cdot 5^n \exp(-2\gamma\tau) + \\ + 15 \cdot 3^n);$$

$$\frac{\partial^n P_5^{(2,0)}(\tau, \gamma)}{\partial \tau^n} = -(-\gamma)^n \exp(-3\gamma\tau)(792 \cdot 13^n \exp(-10\gamma\tau) - \\ - 2310 \cdot 11^n \exp(-8\gamma\tau) + 2520 \cdot 9^n \exp(-6\gamma\tau) - 1260 \cdot 7^n \times \\ \times \exp(-4\gamma\tau) + 280 \cdot 5^n \exp(-2\gamma\tau) - 21 \cdot 3^n).$$



Рис. 1.49. Вид n-ой производной ортогональных функций Якоби 2-ого порядка;  $n = 0..5$ ,  $\gamma = 0,25$ ,  $c = 2$ ,  $\alpha = 2$ ,  $\beta = 0$

$$[1.50] \quad \frac{\partial P_k^{(\alpha,0)}(\tau, \gamma)}{\partial \tau} = -\frac{c\gamma}{2} \sum_{s=0}^k \binom{k}{s} \binom{k+s+\alpha}{s+\alpha} (-1)^s \times \\ \times (2s+\alpha+1) \exp(-(2s+\alpha+1)c\gamma\tau/2).$$

Частные случаи для 1-ой производной функций 0-5 порядков:

$$\begin{aligned} \frac{\partial P_0^{(\alpha,0)}(\tau, \gamma)}{\partial \tau} &= -\frac{(\alpha+1)c\gamma}{2} \exp(-(\alpha+1)c\gamma\tau/2); \\ \frac{\partial P_1^{(\alpha,0)}(\tau, \gamma)}{\partial \tau} &= -\frac{c\gamma}{2} \exp(-(\alpha+1)c\gamma\tau/2) ((\alpha+1)^2 - (\alpha+2) \times \\ &\times (\alpha+3) \exp(-c\gamma\tau)); \\ \frac{\partial P_2^{(\alpha,0)}(\tau, \gamma)}{\partial \tau} &= -\frac{c\gamma}{4} \exp(-(\alpha+1)c\gamma\tau/2) ((\alpha+1)^2(\alpha+2) - \\ &- 2(\alpha+2)(\alpha+3)^2 \exp(-c\gamma\tau) + (\alpha+3)(\alpha+4)(\alpha+5) \exp(-2c\gamma\tau)); \\ \frac{\partial P_3^{(\alpha,0)}(\tau, \gamma)}{\partial \tau} &= -\frac{c\gamma}{12} \exp(-(\alpha+1)c\gamma\tau/2) ((\alpha+1)^2(\alpha+2) \times \\ &\times (\alpha+3) - 3(\alpha+2)(\alpha+3)^2(\alpha+4) \exp(-c\gamma\tau) + 3(\alpha+3)(\alpha+4) \times \\ &\times (\alpha+5)^2 \exp(-2c\gamma\tau) - (\alpha+4)(\alpha+5)(\alpha+6)(\alpha+7) \exp(-3c\gamma\tau)); \\ \frac{\partial P_4^{(\alpha,0)}(\tau, \gamma)}{\partial \tau} &= -\frac{c\gamma}{48} \exp(-(\alpha+1)c\gamma\tau/2) ((\alpha+1)^2(\alpha+2) \times \\ &\times (\alpha+3)(\alpha+4) - 4(\alpha+2)(\alpha+3)^2(\alpha+4)(\alpha+5) \exp(-c\gamma\tau) + \\ &+ 6(\alpha+3)(\alpha+4)(\alpha+5)^2(\alpha+6) \exp(-2c\gamma\tau) - 4(\alpha+4) \times \\ &\times (\alpha+5)(\alpha+6)(\alpha+7)^2 \exp(-3c\gamma\tau) + (\alpha+5)(\alpha+6)(\alpha+7) \times \\ &\times (\alpha+8)(\alpha+9) \exp(-4c\gamma\tau)); \\ \frac{\partial P_5^{(\alpha,0)}(\tau, \gamma)}{\partial \tau} &= -\frac{c\gamma}{240} \exp(-(\alpha+1)c\gamma\tau/2) ((\alpha+1)^2 \times \\ &\times (\alpha+2)(\alpha+3)(\alpha+4)(\alpha+5) - 5(\alpha+2)(\alpha+3)^2(\alpha+4) \times \\ &\times (\alpha+5)(\alpha+6) \exp(-c\gamma\tau) + 10(\alpha+3)(\alpha+4)(\alpha+5)^2 \times \\ &\times (\alpha+6)(\alpha+7) \exp(-2c\gamma\tau) - 10(\alpha+4)(\alpha+5)(\alpha+6) \times \\ &\times (\alpha+7)^2(\alpha+8) \exp(-3c\gamma\tau) + 5(\alpha+5)(\alpha+6)(\alpha+7)(\alpha+8) \times \\ &\times (\alpha+9)^2 \exp(-4c\gamma\tau) - (\alpha+6)(\alpha+7)(\alpha+8)(\alpha+9) \times \\ &\times (\alpha+10)(\alpha+11) \exp(-5c\gamma\tau)). \end{aligned}$$

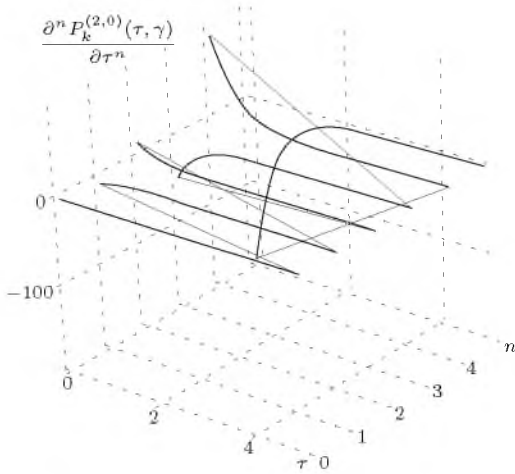

Рис. 1.50. Вид 1-ой производной ортогональных функций Якоби 2-ого порядка: а)  $\gamma = 0,25$ ,  $c = 2$ ,  $\alpha \in [0;5]$ ,  $\beta = 0$ ; б)  $\gamma \in (0;2]$ ,  $c = 2$ ,  $\alpha = 1$ ,  $\beta = 0$

$$[1.51] \quad \frac{\partial^2 P_k^{(\alpha,0)}(\tau, \gamma)}{\partial \tau^2} = \frac{c^2\gamma^2}{4} \sum_{s=0}^k \binom{k}{s} \binom{k+s+\alpha}{s+\alpha} \times \\ \times (-1)^s (2s+\alpha+1)^2 \exp(-(2s+\alpha+1)c\gamma\tau/2).$$

Частные случаи для 2-ой производной функций 0-5 порядков:

$$\begin{aligned} \frac{\partial^2 P_0^{(\alpha,0)}(\tau, \gamma)}{\partial \tau^2} &= \frac{(\alpha+1)^2 c^2 \gamma^2}{4} \exp(-(\alpha+1)c\gamma\tau/2); \\ \frac{\partial^2 P_1^{(\alpha,0)}(\tau, \gamma)}{\partial \tau^2} &= \frac{c^2 \gamma^2}{4} \exp(-(\alpha+1)c\gamma\tau/2) ((\alpha+1)^3 - (\alpha+2) \times \\ &\times (\alpha+3)^2 \exp(-c\gamma\tau)); \\ \frac{\partial^2 P_2^{(\alpha,0)}(\tau, \gamma)}{\partial \tau^2} &= \frac{c^2 \gamma^2}{8} \exp(-(\alpha+1)c\gamma\tau/2) ((\alpha+1)^3(\alpha+2) - \end{aligned}$$

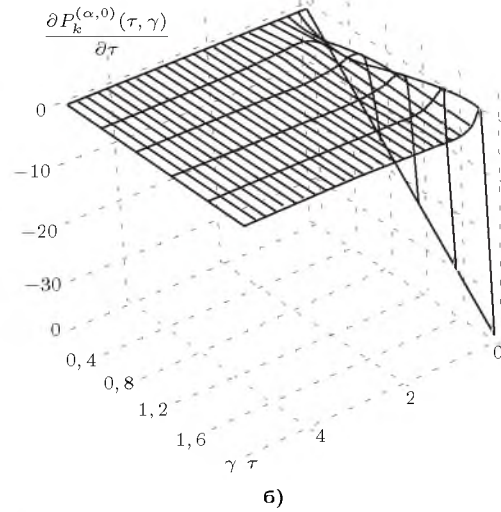
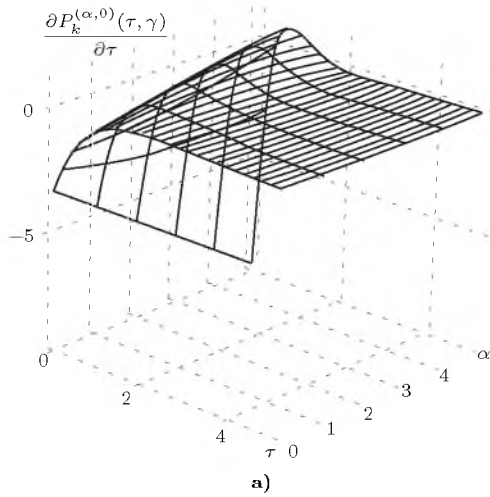

$$\begin{aligned}
 & -2(\alpha+2)(\alpha+3)^3 \exp(-c\gamma\tau) + (\alpha+3)(\alpha+4)(\alpha+5)^2 \times \\
 & \times \exp(-2c\gamma\tau)); \\
 & \frac{\partial^2 P_3^{(\alpha,0)}(\tau, \gamma)}{\partial \tau^2} = \frac{c^2 \gamma^2}{24} \exp(-(\alpha+1)c\gamma\tau/2) ((\alpha+1)^3(\alpha+2) \times \\
 & \times (\alpha+3) - 3(\alpha+2)(\alpha+3)^3(\alpha+4) \exp(-c\gamma\tau) + 3(\alpha+3) \times \\
 & \times (\alpha+4)(\alpha+5)^3 \exp(-2c\gamma\tau) - (\alpha+4)(\alpha+5)(\alpha+6)(\alpha+7)^2 \times \\
 & \times \exp(-3c\gamma\tau)); \\
 & \frac{\partial^2 P_4^{(\alpha,0)}(\tau, \gamma)}{\partial \tau^2} = \frac{c^2 \gamma^2}{96} \exp(-(\alpha+1)c\gamma\tau/2) ((\alpha+1)^3(\alpha+2) \times \\
 & \times (\alpha+3)(\alpha+4) - 4(\alpha+2)(\alpha+3)^3(\alpha+4)(\alpha+5) \exp(-c\gamma\tau) + \\
 & + 6(\alpha+3)(\alpha+4)(\alpha+5)^3(\alpha+6) \exp(-2c\gamma\tau) - 4(\alpha+4)(\alpha+5) \times
 \end{aligned}$$

$$\begin{aligned}
 & \times (\alpha+6)(\alpha+7)^3 \exp(-3c\gamma\tau) + (\alpha+5)(\alpha+6)(\alpha+7)(\alpha+8) \times \\
 & \times (\alpha+9)^2 \exp(-4c\gamma\tau)); \\
 & \frac{\partial^2 P_5^{(\alpha,0)}(\tau, \gamma)}{\partial \tau^2} = \frac{c^2 \gamma^2}{480} \exp(-(\alpha+1)c\gamma\tau/2) ((\alpha+1)^3(\alpha+2) \times \\
 & \times (\alpha+3)(\alpha+4)(\alpha+5) - 5(\alpha+2)(\alpha+3)^3(\alpha+4)(\alpha+5)(\alpha+6) \times \\
 & \times \exp(-c\gamma\tau) + 10(\alpha+3)(\alpha+4)(\alpha+5)^3(\alpha+6)(\alpha+7) \times \\
 & \times \exp(-2c\gamma\tau) - 10(\alpha+4)(\alpha+5)(\alpha+6)(\alpha+7)^3(\alpha+8) \times \\
 & \times \exp(-3c\gamma\tau) + 5(\alpha+5)(\alpha+6)(\alpha+7)(\alpha+8)(\alpha+9)^3 \times \\
 & \times \exp(-4c\gamma\tau) - (\alpha+6)(\alpha+7)(\alpha+8)(\alpha+9)(\alpha+10)(\alpha+11)^2 \times \\
 & \times \exp(-5c\gamma\tau)).
 \end{aligned}$$



Рис. 1.51. Вид 2-ой производной ортогональных функций Якоби 2-ого порядка: а)  $\gamma = 0, 25, c = 2, \alpha \in [0; 5], \beta = 0$ ; б)  $\gamma \in (0; 2], c = 2, \alpha = 1, \beta = 0$

[1.52] 
$$\frac{\partial^3 P_k^{(\alpha,0)}(\tau, \gamma)}{\partial \tau^3} = -\frac{c^3 \gamma^3}{8} \sum_{s=0}^k \binom{k}{s} \binom{k+s+\alpha}{s+\alpha} \times \\
 \times (-1)^s (2s+\alpha+1)^3 \exp(-(2s+\alpha+1)c\gamma\tau/2).$$

Частные случаи для 3-ей производной функций 0-5 порядков:

$$\begin{aligned}
 & \frac{\partial^3 P_0^{(\alpha,0)}(\tau, \gamma)}{\partial \tau^3} = -\frac{(\alpha+1)^3 c^3 \gamma^3}{8} \exp(-(\alpha+1)c\gamma\tau/2); \\
 & \frac{\partial^3 P_1^{(\alpha,0)}(\tau, \gamma)}{\partial \tau^3} = -\frac{c^3 \gamma^3}{8} \exp(-(\alpha+1)c\gamma\tau/2) ((\alpha+1)^4 - \\
 & - (\alpha+2)(\alpha+3)^3 \exp(-c\gamma\tau)); \\
 & \frac{\partial^3 P_2^{(\alpha,0)}(\tau, \gamma)}{\partial \tau^3} = -\frac{c^3 \gamma^3}{16} \exp(-(\alpha+1)c\gamma\tau/2) ((\alpha+1)^4(\alpha+2) - \\
 & - 2(\alpha+2)(\alpha+3)^4 \exp(-c\gamma\tau) + (\alpha+3)(\alpha+4)(\alpha+5)^3 \times \\
 & \times \exp(-2c\gamma\tau)); \\
 & \frac{\partial^3 P_3^{(\alpha,0)}(\tau, \gamma)}{\partial \tau^3} = -\frac{c^3 \gamma^3}{48} \exp(-(\alpha+1)c\gamma\tau/2) ((\alpha+1)^4(\alpha+2) \times
 \end{aligned}$$

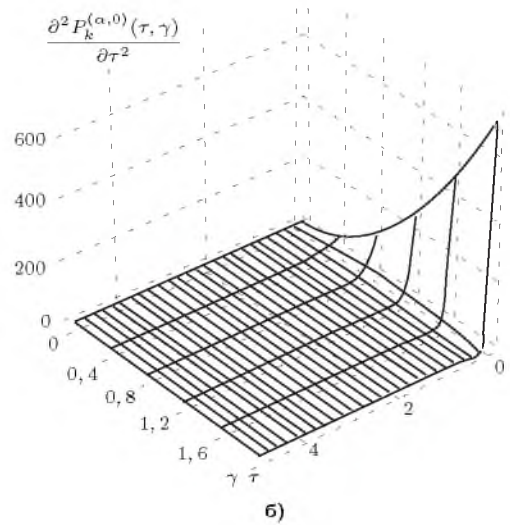
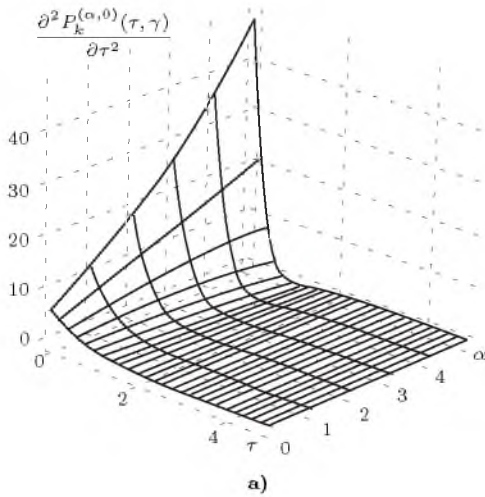
$$\begin{aligned}
 & \times (\alpha+3) - 3(\alpha+2)(\alpha+3)^4(\alpha+4) \exp(-c\gamma\tau) + 3(\alpha+3)(\alpha+4) \times \\
 & \times (\alpha+5)^4 \exp(-2c\gamma\tau) - (\alpha+4)(\alpha+5)(\alpha+6)(\alpha+7)^3 \times \\
 & \times \exp(-3c\gamma\tau)); \\
 & \frac{\partial^3 P_4^{(\alpha,0)}(\tau, \gamma)}{\partial \tau^3} = -\frac{c^3 \gamma^3}{192} \exp(-(\alpha+1)c\gamma\tau/2) ((\alpha+1)^4(\alpha+2) \times \\
 & \times (\alpha+3)(\alpha+4) - 4(\alpha+2)(\alpha+3)^4(\alpha+4)(\alpha+5) \exp(-c\gamma\tau) + \\
 & + 6(\alpha+3)(\alpha+4)(\alpha+5)^4(\alpha+6) \exp(-2c\gamma\tau) - 4(\alpha+4)(\alpha+5) \times \\
 & \times (\alpha+6)(\alpha+7)^4 \exp(-3c\gamma\tau) + (\alpha+5)(\alpha+6)(\alpha+7)(\alpha+8) \times \\
 & \times (\alpha+9)^3 \exp(-4c\gamma\tau)); \\
 & \frac{\partial^3 P_5^{(\alpha,0)}(\tau, \gamma)}{\partial \tau^3} = -\frac{c^3 \gamma^3}{960} \exp(-(\alpha+1)c\gamma\tau/2) ((\alpha+1)^4(\alpha+2) \times \\
 & \times (\alpha+3)(\alpha+4)(\alpha+5) - 5(\alpha+2)(\alpha+3)^4(\alpha+4)(\alpha+5)(\alpha+6) \times \\
 & \times \exp(-c\gamma\tau) + 10(\alpha+3)(\alpha+4)(\alpha+5)^4(\alpha+6)(\alpha+7) \times \\
 & \times \exp(-2c\gamma\tau) - 10(\alpha+4)(\alpha+5)(\alpha+6)(\alpha+7)^4(\alpha+8) \times \\
 & \times \exp(-3c\gamma\tau) + 5(\alpha+5)(\alpha+6)(\alpha+7)(\alpha+8)(\alpha+9)^4 \times \\
 & \times \exp(-4c\gamma\tau) - (\alpha+6)(\alpha+7)(\alpha+8)(\alpha+9)(\alpha+10)(\alpha+11)^3 \times \\
 & \times \exp(-5c\gamma\tau)).
 \end{aligned}$$



Рис. 1.52. Вид 3-ой производной ортогональных функций Якоби 2-ого порядка: а)  $\gamma = 0,25$ ,  $c = 2$ ,  $\alpha \in [0; 5]$ ,  $\beta = 0$ ; б)  $\gamma \in (0; 2]$ ,  $c = 2$ ,  $\alpha = 1$ ,  $\beta = 0$

$$[1.53] \quad \frac{\partial^n P_k^{(\alpha,0)}(\tau, \gamma)}{\partial \tau^n} = \left(-\frac{c\gamma}{2}\right)^n \sum_{s=0}^k \binom{k}{s} \binom{k+s+\alpha}{s+\alpha} \times \\ \times (-1)^s (2s+\alpha+1)^n \exp(-(2s+\alpha+1)c\gamma\tau/2).$$

Частные случаи для  $n$ -ой производной функций 0-5 порядков:

$$\frac{\partial^n P_0^{(\alpha,0)}(\tau, \gamma)}{\partial \tau^n} = \left(-\frac{c\gamma}{2}\right)^n \exp(-(\alpha+1)c\gamma\tau/2);$$

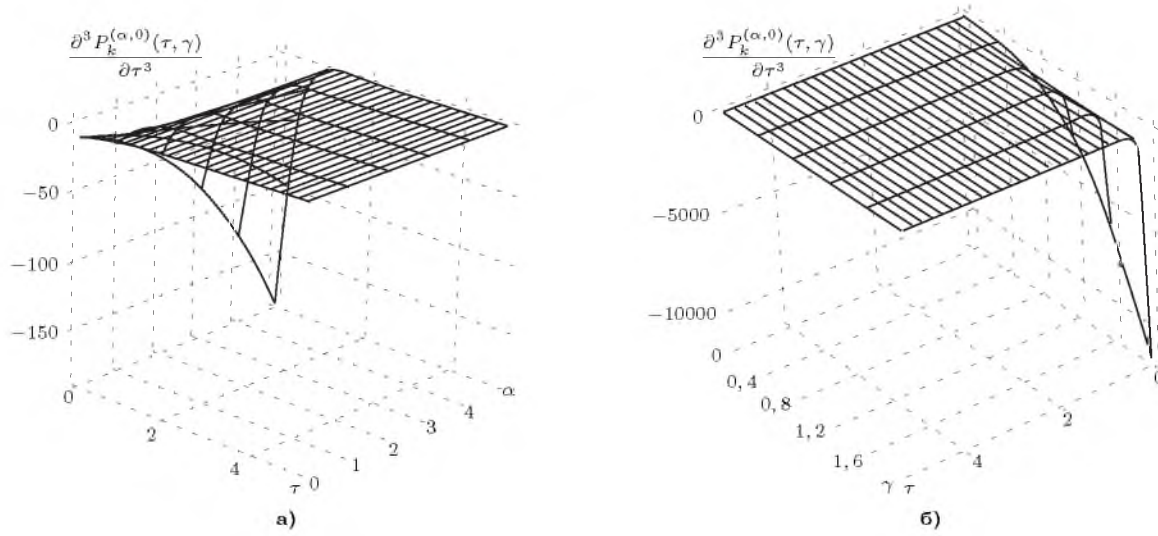
$$\frac{\partial^n P_1^{(\alpha,0)}(\tau, \gamma)}{\partial \tau^n} = \left(-\frac{c\gamma}{2}\right)^n \exp(-(\alpha+1)c\gamma\tau/2) ((\alpha+1)^{n+1} - \\ - (\alpha+2)(\alpha+3)^n \exp(-c\gamma\tau));$$

$$\frac{\partial^n P_2^{(\alpha,0)}(\tau, \gamma)}{\partial \tau^n} = \left(-\frac{c\gamma}{2}\right)^n \exp(-(\alpha+1)c\gamma\tau/2) ((\alpha+1)^{n+1} \times \\ \times (\alpha+2) - 2(\alpha+2)(\alpha+3)^{n+1} \exp(-c\gamma\tau) + (\alpha+3)(\alpha+4)(\alpha+5)^n \times \\ \times \exp(-2c\gamma\tau));$$

$$\frac{\partial^n P_3^{(\alpha,0)}(\tau, \gamma)}{\partial \tau^n} = \left(-\frac{c\gamma}{2}\right)^n \exp(-(\alpha+1)c\gamma\tau/2) ((\alpha+1)^{n+1} \times$$

$$\times (\alpha+2)(\alpha+3) - 3(\alpha+2)(\alpha+3)^{n+1}(\alpha+4) \exp(-c\gamma\tau) + 3 \times \\ \times (\alpha+3)(\alpha+4)(\alpha+5)^{n+1} \exp(-2c\gamma\tau) - (\alpha+4)(\alpha+5)(\alpha+6) \times \\ \times (\alpha+7)^n \exp(-3c\gamma\tau));$$

$$\frac{\partial^n P_4^{(\alpha,0)}(\tau, \gamma)}{\partial \tau^n} = \left(-\frac{c\gamma}{2}\right)^n \exp(-(\alpha+1)c\gamma\tau/2) ((\alpha+1)^{n+1} \times$$

$$\times (\alpha+2)(\alpha+3)(\alpha+4) - 4(\alpha+2)(\alpha+3)^{n+1}(\alpha+4)(\alpha+5) \times \\ \times \exp(-c\gamma\tau) + 6(\alpha+3)(\alpha+4)(\alpha+5)^{n+1}(\alpha+6) \exp(-2c\gamma\tau) - \\ - 4(\alpha+4)(\alpha+5)(\alpha+6)(\alpha+7)^{n+1} \exp(-3c\gamma\tau) + (\alpha+5)(\alpha+6) \times \\ \times (\alpha+7)(\alpha+8)(\alpha+9)^n \exp(-4c\gamma\tau));$$

$$\frac{\partial^n P_5^{(\alpha,0)}(\tau, \gamma)}{\partial \tau^n} = \left(-\frac{c\gamma}{2}\right)^n \exp(-(\alpha+1)c\gamma\tau/2) ((\alpha+1)^{n+1} \times$$

$$\times (\alpha+2)(\alpha+3)(\alpha+4)(\alpha+5) - 5(\alpha+2)(\alpha+3)^{n+1}(\alpha+4) \times \\ \times (\alpha+5)(\alpha+6) \exp(-c\gamma\tau) + 10(\alpha+3)(\alpha+4)(\alpha+5)^{n+1}(\alpha+6) \times \\ \times (\alpha+7) \exp(-2c\gamma\tau) - 10(\alpha+4)(\alpha+5)(\alpha+6)(\alpha+7)^{n+1} \times \\ \times (\alpha+8) \exp(-3c\gamma\tau) + 5(\alpha+5)(\alpha+6)(\alpha+7)(\alpha+8)(\alpha+9)^{n+1} \times \\ \times \exp(-4c\gamma\tau) - (\alpha+6)(\alpha+7)(\alpha+8)(\alpha+9)(\alpha+10)(\alpha+11)^n \times \\ \times \exp(-5c\gamma\tau)).$$



Рис. 1.53. Вид n-ой производной ортогональных функций Якоби 2-ого порядка: а)  $n = 0.5, \gamma = 0, 25, c = 2, \alpha \in [0; 5], \beta = 0$ ; б)  $n = 0.5, \gamma \in (0; 2], c = 2, \alpha = 1, \beta = 0$

[1.54] 
$$\frac{\partial P_k^{(0,1)}(\tau, \gamma)}{\partial \tau} = -\gamma \sum_{s=0}^k \binom{k}{s} \binom{k+s+1}{s} (-1)^s \times (2s+1) \exp(-(2s+1)\gamma\tau).$$

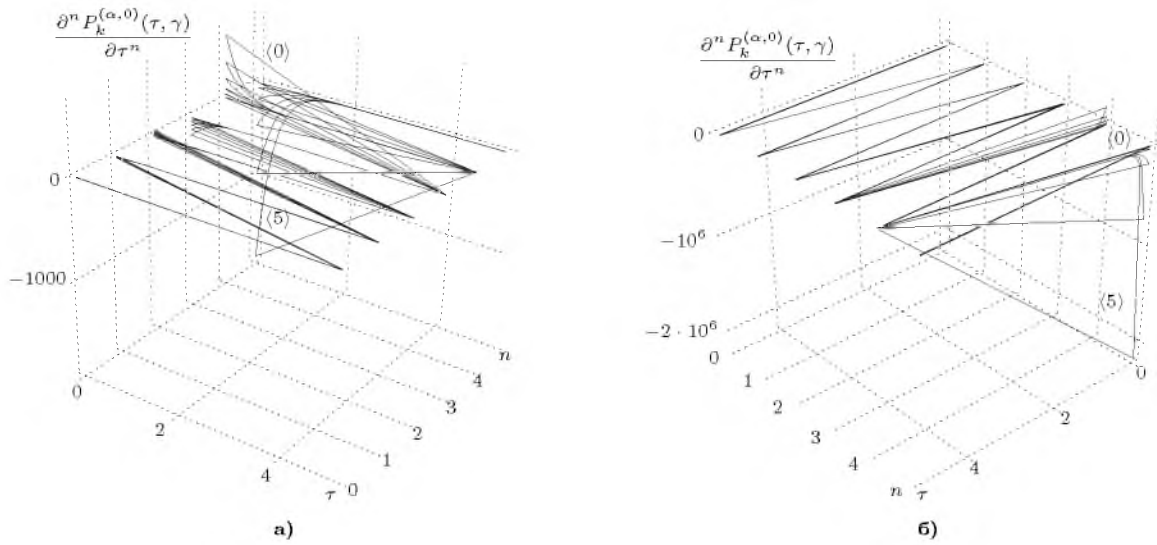

Рис. 1.54. Вид 1-ой производной ортогональных функций Якоби 0-5 порядков;  $\gamma = 0, 25, c = 2, \alpha = 0, \beta = 1$

Частные случаи для 1-ой производной функций 0-5 порядков:

$$\begin{aligned} \frac{\partial P_0^{(0,1)}(\tau, \gamma)}{\partial \tau} &= -\gamma \exp(-\gamma\tau); \\ \frac{\partial P_1^{(0,1)}(\tau, \gamma)}{\partial \tau} &= \gamma \exp(-\gamma\tau)(9 \exp(-2\gamma\tau) - 1); \\ \frac{\partial P_2^{(0,1)}(\tau, \gamma)}{\partial \tau} &= -\gamma \exp(-\gamma\tau)(50 \exp(-4\gamma\tau) - 24 \exp(-2\gamma\tau) + 1); \\ \frac{\partial P_3^{(0,1)}(\tau, \gamma)}{\partial \tau} &= \gamma \exp(-\gamma\tau)(245 \exp(-6\gamma\tau) - 225 \exp(-4\gamma\tau) + 45 \exp(-2\gamma\tau) - 1); \\ \frac{\partial P_4^{(0,1)}(\tau, \gamma)}{\partial \tau} &= -\gamma \exp(-\gamma\tau)(1134 \exp(-8\gamma\tau) - 1568 \times \\ &\times \exp(-6\gamma\tau) + 630 \exp(-4\gamma\tau) - 72 \exp(-2\gamma\tau) + 1); \\ \frac{\partial P_5^{(0,1)}(\tau, \gamma)}{\partial \tau} &= \gamma \exp(-\gamma\tau)(5082 \exp(-10\gamma\tau) - 9450 \times \\ &\times \exp(-8\gamma\tau) + 5880 \exp(-6\gamma\tau) - 1400 \exp(-4\gamma\tau) + 105 \times \\ &\times \exp(-2\gamma\tau) - 1). \end{aligned}$$

[1.55] 
$$\frac{\partial^2 P_k^{(0,1)}(\tau, \gamma)}{\partial \tau^2} = \gamma^2 \sum_{s=0}^k \binom{k}{s} \binom{k+s+1}{s} (-1)^s \times (2s+1)^2 \exp(-(2s+1)\gamma\tau).$$

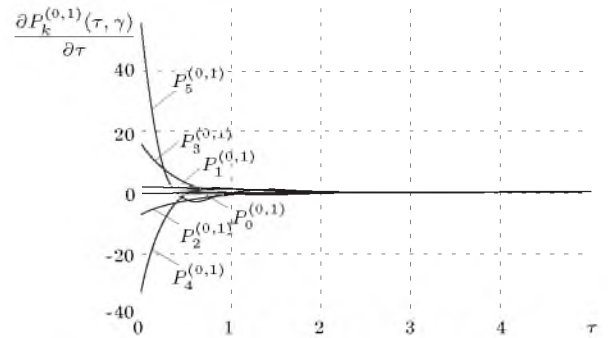
Частные случаи для 2-ой производной функций 0-5 порядков:

$$\begin{aligned} \frac{\partial^2 P_0^{(0,1)}(\tau, \gamma)}{\partial \tau^2} &= \gamma^2 \exp(-\gamma\tau); \\ \frac{\partial^2 P_1^{(0,1)}(\tau, \gamma)}{\partial \tau^2} &= -\gamma^2 \exp(-\gamma\tau)(27 \exp(-2\gamma\tau) - 1); \\ \frac{\partial^2 P_2^{(0,1)}(\tau, \gamma)}{\partial \tau^2} &= \gamma^2 \exp(-\gamma\tau)(250 \exp(-4\gamma\tau) - 72 \times \\ &\times \exp(-2\gamma\tau) + 1); \\ \frac{\partial^2 P_3^{(0,1)}(\tau, \gamma)}{\partial \tau^2} &= -\gamma^2 \exp(-\gamma\tau)(1715 \exp(-6\gamma\tau) - 1125 \times \\ &\times \exp(-4\gamma\tau) + 135 \exp(-2\gamma\tau) - 1); \\ \frac{\partial^2 P_4^{(0,1)}(\tau, \gamma)}{\partial \tau^2} &= \gamma^2 \exp(-\gamma\tau)(10206 \exp(-8\gamma\tau) - 10976 \times \end{aligned}$$

$$\begin{aligned} & \times \exp(-6\gamma\tau) + 3150 \exp(-4\gamma\tau) - 216 \exp(-2\gamma\tau) + 1); \\ & \frac{\partial^2 P_5^{(0,1)}(\tau, \gamma)}{\partial \tau^2} = -\gamma^2 \exp(-\gamma\tau) (55902 \exp(-10\gamma\tau) - 85050 \times \\ & \times \exp(-8\gamma\tau) + 41160 \exp(-6\gamma\tau) - 7000 \exp(-4\gamma\tau) + 315 \times \\ & \times \exp(-2\gamma\tau) - 1). \end{aligned}$$



Рис. 1.55. Вид 2-ой производной ортогональных функций Якоби 0-5 порядков;  $\gamma = 0, 25, c = 2, \alpha = 0, \beta = 1$

$$[1.56] \quad \frac{\partial^3 P_k^{(0,1)}(\tau, \gamma)}{\partial \tau^3} = -\gamma^3 \sum_{s=0}^k \binom{k}{s} \binom{k+s+1}{s} (-1)^s \times (2s+1)^3 \exp(-(2s+1)\gamma\tau).$$

Частные случаи для 3-ей производной функций 0-5 порядков:

$$\begin{aligned} \frac{\partial^3 P_0^{(0,1)}(\tau, \gamma)}{\partial \tau^3} &= -\gamma^3 \exp(-\gamma\tau); \\ \frac{\partial^3 P_1^{(0,1)}(\tau, \gamma)}{\partial \tau^3} &= \gamma^3 \exp(-\gamma\tau) (81 \exp(-2\gamma\tau) - 1); \\ \frac{\partial^3 P_2^{(0,1)}(\tau, \gamma)}{\partial \tau^3} &= -\gamma^3 \exp(-\gamma\tau) (1250 \exp(-4\gamma\tau) - 216 \times \\ & \times \exp(-2\gamma\tau) + 1); \\ \frac{\partial^3 P_3^{(0,1)}(\tau, \gamma)}{\partial \tau^3} &= \gamma^3 \exp(-\gamma\tau) (12005 \exp(-6\gamma\tau) - 5625 \times \\ & \times \exp(-4\gamma\tau) + 405 \exp(-2\gamma\tau) - 1); \\ \frac{\partial^3 P_4^{(0,1)}(\tau, \gamma)}{\partial \tau^3} &= -\gamma^3 \exp(-\gamma\tau) (91854 \exp(-8\gamma\tau) - 76832 \times \\ & \times \exp(-6\gamma\tau) + 15750 \exp(-4\gamma\tau) - 648 \exp(-2\gamma\tau) + 1); \\ \frac{\partial^3 P_5^{(0,1)}(\tau, \gamma)}{\partial \tau^3} &= \gamma^3 \exp(-\gamma\tau) (614922 \exp(-10\gamma\tau) - \\ & - 765450 \exp(-8\gamma\tau) + 288120 \exp(-6\gamma\tau) - 35000 \exp(-4\gamma\tau) + \\ & + 945 \exp(-2\gamma\tau) - 1). \end{aligned}$$

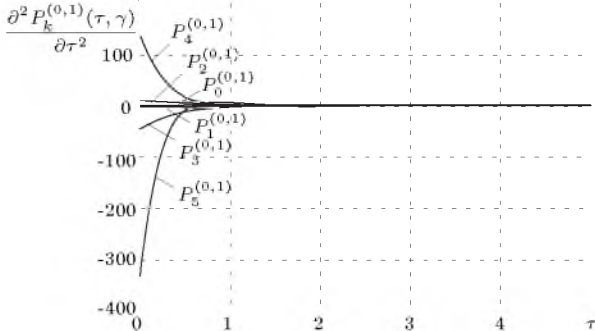

Рис. 1.56. Вид 3-ей производной ортогональных функций Якоби 0-5 порядков;  $\gamma = 0, 25, c = 2, \alpha = 0, \beta = 1$

$$[1.57] \quad \frac{\partial^n P_k^{(0,1)}(\tau, \gamma)}{\partial \tau^n} = (-\gamma)^n \sum_{s=0}^k \binom{k}{s} \binom{k+s+1}{s} (-1)^s (2s+1)^n \exp(-(2s+1)\gamma\tau).$$

Частные случаи для n-ой производной функций 0-5 порядков:

$$\begin{aligned} \frac{\partial^n P_0^{(0,1)}(\tau, \gamma)}{\partial \tau^n} &= (-\gamma)^n \exp(-\gamma\tau); \\ \frac{\partial^n P_1^{(0,1)}(\tau, \gamma)}{\partial \tau^n} &= -(-\gamma)^n \exp(-\gamma\tau) (3 \cdot 3^n \exp(-2\gamma\tau) - 1); \\ \frac{\partial^n P_2^{(0,1)}(\tau, \gamma)}{\partial \tau^n} &= (-\gamma)^n \exp(-\gamma\tau) (10 \cdot 5^n \exp(-4\gamma\tau) - 8 \cdot 3^n \times \\ & \times \exp(-2\gamma\tau) + 1); \\ \frac{\partial^n P_3^{(0,1)}(\tau, \gamma)}{\partial \tau^n} &= -(-\gamma)^n \exp(-\gamma\tau) (35 \cdot 7^n \exp(-6\gamma\tau) - \\ & - 45 \cdot 5^n \exp(-4\gamma\tau) + 15 \cdot 3^n \exp(-2\gamma\tau) - 1); \\ \frac{\partial^n P_4^{(0,1)}(\tau, \gamma)}{\partial \tau^n} &= (-\gamma)^n \exp(-\gamma\tau) (126 \cdot 9^n \exp(-8\gamma\tau) - \\ & - 224 \cdot 7^n \exp(-6\gamma\tau) + 126 \cdot 5^n \exp(-4\gamma\tau) - 24 \cdot 3^n \exp(-2\gamma\tau) + \\ & + 1); \\ \frac{\partial^n P_5^{(0,1)}(\tau, \gamma)}{\partial \tau^n} &= -(-\gamma)^n \exp(-\gamma\tau) (462 \cdot 11^n \exp(-10\gamma\tau) - \\ & - 1050 \cdot 9^n \exp(-8\gamma\tau) + 840 \cdot 7^n \exp(-6\gamma\tau) - 280 \cdot 5^n \exp(-4\gamma\tau) + \\ & + 35 \cdot 3^n \exp(-2\gamma\tau) - 1). \end{aligned}$$

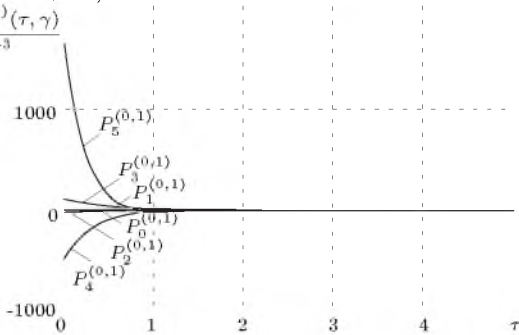

Рис. 1.57. Вид n-ой производной ортогональных функций Якоби 2-ого порядка;  $n = 0..5, \gamma = 0, 25, c = 2, \alpha = 0, \beta = 1$

$$[1.58] \quad \frac{\partial P_k^{(0,2)}(\tau, \gamma)}{\partial \tau} = -\gamma \sum_{s=0}^k \binom{k}{s} \binom{k+s+2}{s} (-1)^s \times (2s+1) \exp(-(2s+1)\gamma\tau).$$

Частные случаи для 1-ой производной функций 0-5 порядков:

$$\begin{aligned} \frac{\partial P_0^{(0,2)}(\tau, \gamma)}{\partial \tau} &= -\gamma \exp(-\gamma\tau); \\ \frac{\partial P_1^{(0,2)}(\tau, \gamma)}{\partial \tau} &= \gamma \exp(-\gamma\tau) (12 \exp(-2\gamma\tau) - 1); \\ \frac{\partial P_2^{(0,2)}(\tau, \gamma)}{\partial \tau} &= -\gamma \exp(-\gamma\tau) (75 \exp(-4\gamma\tau) - 30 \exp(-2\gamma\tau) + \end{aligned}$$

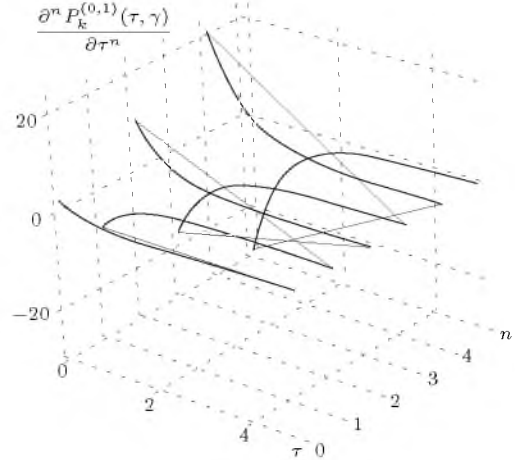
$$\begin{aligned}
 &+ 1); \\
 \frac{\partial P_3^{(0,2)}(\tau, \gamma)}{\partial \tau} &= \gamma \exp(-\gamma\tau)(392 \exp(-6\gamma\tau) - 315 \exp(-4\gamma\tau) + \\
 &+ 54 \exp(-2\gamma\tau) - 1); \\
 \frac{\partial P_4^{(0,2)}(\tau, \gamma)}{\partial \tau} &= -\gamma \exp(-\gamma\tau)(1890 \exp(-8\gamma\tau) - 2352 \times \\
 &\times \exp(-6\gamma\tau) + 840 \exp(-4\gamma\tau) - 84 \exp(-2\gamma\tau) + 1); \\
 \frac{\partial P_5^{(0,2)}(\tau, \gamma)}{\partial \tau} &= \gamma \exp(-\gamma\tau)(8712 \exp(-10\gamma\tau) - 14850 \times \\
 &\times \exp(-8\gamma\tau) + 8400 \exp(-6\gamma\tau) - 1800 \exp(-4\gamma\tau) + 120 \times \\
 &\times \exp(-2\gamma\tau) - 1). \\
 \frac{\partial P_k^{(0,2)}(\tau, \gamma)}{\partial \tau} &
 \end{aligned}$$



Рис. 1.58. Вид 1-ой производной ортогональных функций Якоби 0-5 порядков;  $\gamma = 0, 25$ ,  $c = 2$ ,  $\alpha = 0$ ,  $\beta = 2$

$$[1.59] \quad \frac{\partial^2 P_k^{(0,2)}(\tau, \gamma)}{\partial \tau^2} = \gamma^2 \sum_{s=0}^k \binom{k}{s} \binom{k+s+2}{s} (-1)^s \times \\
 \times (2s+1)^2 \exp(-2s+1)\gamma\tau.$$

Частные случаи для 2-ой производной функций 0-5 порядков:

$$\begin{aligned}
 \frac{\partial^2 P_0^{(0,2)}(\tau, \gamma)}{\partial \tau^2} &= \gamma^2 \exp(-\gamma\tau); \\
 \frac{\partial^2 P_1^{(0,2)}(\tau, \gamma)}{\partial \tau^2} &= -\gamma^2 \exp(-\gamma\tau)(36 \exp(-2\gamma\tau) - 1); \\
 \frac{\partial^2 P_2^{(0,2)}(\tau, \gamma)}{\partial \tau^2} &= \gamma^2 \exp(-\gamma\tau)(375 \exp(-4\gamma\tau) - 90 \times \\
 &\times \exp(-2\gamma\tau) + 1); \\
 \frac{\partial^2 P_3^{(0,2)}(\tau, \gamma)}{\partial \tau^2} &= -\gamma^2 \exp(-\gamma\tau)(2744 \exp(-6\gamma\tau) - 1575 \times \\
 &\times \exp(-4\gamma\tau) + 162 \exp(-2\gamma\tau) - 1); \\
 \frac{\partial^2 P_4^{(0,2)}(\tau, \gamma)}{\partial \tau^2} &= \gamma^2 \exp(-\gamma\tau)(17010 \exp(-8\gamma\tau) - 16464 \times \\
 &\times \exp(-6\gamma\tau) + 4200 \exp(-4\gamma\tau) - 252 \exp(-2\gamma\tau) + 1); \\
 \frac{\partial^2 P_5^{(0,2)}(\tau, \gamma)}{\partial \tau^2} &= -\gamma^2 \exp(-\gamma\tau)(95832 \exp(-10\gamma\tau) - 133650 \times \\
 &\times \exp(-8\gamma\tau) + 58800 \exp(-6\gamma\tau) - 9000 \exp(-4\gamma\tau) + 360 \times \\
 &\times \exp(-2\gamma\tau) - 1).
 \end{aligned}$$

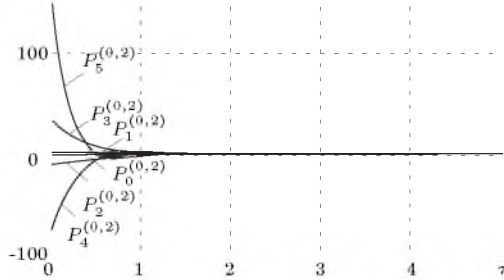

Рис. 1.59. Вид 2-ой производной ортогональных функций Якоби 0-5 порядков;  $\gamma = 0, 25$ ,  $c = 2$ ,  $\alpha = 0$ ,  $\beta = 2$

$$[1.60] \quad \frac{\partial^3 P_k^{(0,2)}(\tau, \gamma)}{\partial \tau^3} = -\gamma^3 \sum_{s=0}^k \binom{k}{s} \binom{k+s+2}{s} (-1)^s \times \\
 \times (2s+1)^3 \exp(-2s+1)\gamma\tau.$$

Частные случаи для 3-ей производной функций 0-5 порядков:

$$\begin{aligned}
 \frac{\partial^3 P_0^{(0,2)}(\tau, \gamma)}{\partial \tau^3} &= -\gamma^3 \exp(-\gamma\tau); \\
 \frac{\partial^3 P_1^{(0,2)}(\tau, \gamma)}{\partial \tau^3} &= \gamma^3 \exp(-\gamma\tau)(108 \exp(-2\gamma\tau) - 1); \\
 \frac{\partial^3 P_2^{(0,2)}(\tau, \gamma)}{\partial \tau^3} &= -\gamma^3 \exp(-\gamma\tau)(1875 \exp(-4\gamma\tau) - 270 \times \\
 &\times \exp(-2\gamma\tau) + 1); \\
 \frac{\partial^3 P_3^{(0,2)}(\tau, \gamma)}{\partial \tau^3} &= \gamma^3 \exp(-\gamma\tau)(19208 \exp(-6\gamma\tau) - 7875 \times \\
 &\times \exp(-4\gamma\tau) + 486 \exp(-2\gamma\tau) - 1); \\
 \frac{\partial^3 P_4^{(0,2)}(\tau, \gamma)}{\partial \tau^3} &= -\gamma^3 \exp(-\gamma\tau)(153090 \exp(-8\gamma\tau) - 115248 \times \\
 &\times \exp(-6\gamma\tau) + 21000 \exp(-4\gamma\tau) - 756 \exp(-2\gamma\tau) + 1); \\
 \frac{\partial^3 P_5^{(0,2)}(\tau, \gamma)}{\partial \tau^3} &= \gamma^3 \exp(-\gamma\tau)(1054152 \exp(-10\gamma\tau) - \\
 &- 1202850 \exp(-8\gamma\tau) + 411600 \exp(-6\gamma\tau) - 45000 \exp(-4\gamma\tau) + \\
 &+ 1080 \exp(-2\gamma\tau) - 1).
 \end{aligned}$$

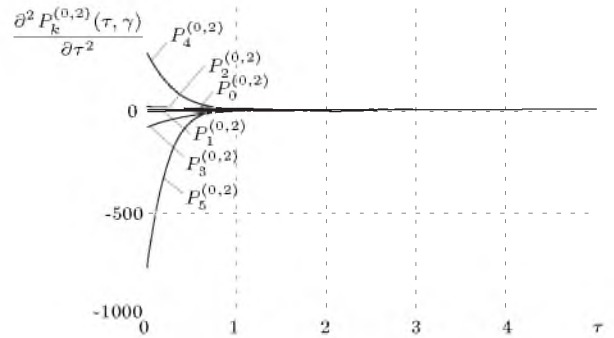

Рис. 1.60. Вид 3-ей производной ортогональных функций Якоби 0-5 порядков;  $\gamma = 0, 25$ ,  $c = 2$ ,  $\alpha = 0$ ,  $\beta = 2$

$$[1.61] \quad \frac{\partial^n P_k^{(0,2)}(\tau, \gamma)}{\partial \tau^n} = (-\gamma)^n \sum_{s=0}^k \binom{k}{s} \binom{k+s+2}{s} \times \\ \times (-1)^s (2s+1)^n \exp(-(2s+1)\gamma\tau).$$

Частные случаи для  $n$ -ой производной функций 0-5 порядков:

$$\begin{aligned} \frac{\partial^n P_0^{(0,2)}(\tau, \gamma)}{\partial \tau^n} &= (-\gamma)^n \exp(-\gamma\tau); \\ \frac{\partial^n P_1^{(0,2)}(\tau, \gamma)}{\partial \tau^n} &= -(-\gamma)^n \exp(-\gamma\tau) (4 \cdot 3^n \exp(-2\gamma\tau) - 1); \\ \frac{\partial^n P_2^{(0,2)}(\tau, \gamma)}{\partial \tau^n} &= (-\gamma)^n \exp(-\gamma\tau) (15 \cdot 5^n \exp(-4\gamma\tau) - 10 \cdot 3^n \times \\ &\times \exp(-2\gamma\tau) + 1); \\ \frac{\partial^n P_3^{(0,2)}(\tau, \gamma)}{\partial \tau^n} &= -(-\gamma)^n \exp(-\gamma\tau) (56 \cdot 7^n \exp(-6\gamma\tau) - \\ &- 63 \cdot 5^n \exp(-4\gamma\tau) + 18 \cdot 3^n \exp(-2\gamma\tau) - 1); \\ \frac{\partial^n P_4^{(0,2)}(\tau, \gamma)}{\partial \tau^n} &= (-\gamma)^n \exp(-\gamma\tau) (210 \cdot 9^n \exp(-8\gamma\tau) - \\ &- 336 \cdot 7^n \exp(-6\gamma\tau) + 168 \cdot 5^n \exp(-4\gamma\tau) - 28 \cdot 3^n \exp(-2\gamma\tau) + \\ &+ 1); \\ \frac{\partial^n P_5^{(0,2)}(\tau, \gamma)}{\partial \tau^n} &= -(-\gamma)^n \exp(-\gamma\tau) (792 \cdot 11^n \exp(-10\gamma\tau) - \\ &- 1650 \cdot 9^n \exp(-8\gamma\tau) + 1200 \cdot 7^n \exp(-6\gamma\tau) - 360 \cdot 5^n \exp(-4\gamma\tau) + \\ &+ 40 \cdot 3^n \exp(-2\gamma\tau) - 1). \end{aligned}$$

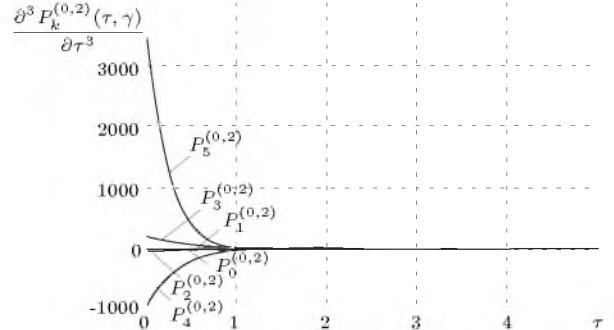

Рис. 1.61. Вид  $n$ -ой производной ортогональных функций Якоби 2-ого порядка;  $n = 0, 5$ ,  $\gamma = 0, 25$ ,  $c = 2$ ,  $\alpha = 0$ ,  $\beta = 2$

$$[1.62] \quad \frac{\partial P_k^{(0,\beta)}(\tau, \gamma)}{\partial \tau} = -\frac{c\gamma}{2} \sum_{s=0}^k \binom{k}{s} \binom{k+s+\beta}{s} (-1)^s \times \\ \times (2s+1) \exp(-(2s+1)c\gamma\tau/2).$$

Частные случаи для 1-ой производной функций 0-5 порядков:

$$\begin{aligned} \frac{\partial P_0^{(0,\beta)}(\tau, \gamma)}{\partial \tau} &= -\frac{c\gamma}{2} \exp(-c\gamma\tau/2); \\ \frac{\partial P_1^{(0,\beta)}(\tau, \gamma)}{\partial \tau} &= -\frac{c\gamma}{2} \exp(-c\gamma\tau/2) (1 - 3(\beta+2) \exp(-c\gamma\tau)); \\ \frac{\partial P_2^{(0,\beta)}(\tau, \gamma)}{\partial \tau} &= -\frac{c\gamma}{2} \exp(-c\gamma\tau/2) (1 - 6(\beta+3) \exp(-c\gamma\tau) + \\ &+ 5(\beta+3)(\beta+4) \exp(-2c\gamma\tau/2)); \\ \frac{\partial P_3^{(0,\beta)}(\tau, \gamma)}{\partial \tau} &= -\frac{c\gamma}{2} \exp(-c\gamma\tau/2) (1 - 9(\beta+4) \exp(-c\gamma\tau) + \\ &+ 15(\beta+4)(\beta+5) \exp(-2c\gamma\tau/2) - 7(\beta+4)(\beta+5)(\beta+6) \times \\ &\times \exp(-3c\gamma\tau/6)); \\ \frac{\partial P_4^{(0,\beta)}(\tau, \gamma)}{\partial \tau} &= -\frac{c\gamma}{2} \exp(-c\gamma\tau/2) (1 - 12(\beta+5) \exp(-c\gamma\tau) + \\ &+ 15(\beta+5)(\beta+6) \exp(-2c\gamma\tau) - 14(\beta+5)(\beta+6)(\beta+7) \times \\ &\times \exp(-3c\gamma\tau/3) + 3(\beta+5)(\beta+6)(\beta+7)(\beta+8) \exp(-4c\gamma\tau/8)); \\ \frac{\partial P_5^{(0,\beta)}(\tau, \gamma)}{\partial \tau} &= -\frac{c\gamma}{2} \exp(-c\gamma\tau/2) (1 - 15(\beta+6) \exp(-c\gamma\tau) + \\ &+ 25(\beta+6)(\beta+7) \exp(-2c\gamma\tau) - 35(\beta+6)(\beta+7)(\beta+8) \times \\ &\times \exp(-3c\gamma\tau/3) + 15(\beta+6)(\beta+7)(\beta+8)(\beta+9) \exp(-4c\gamma\tau/8) - \\ &- 11(\beta+6)(\beta+7)(\beta+8)(\beta+9)(\beta+10) \exp(-5c\gamma\tau/120)). \end{aligned}$$

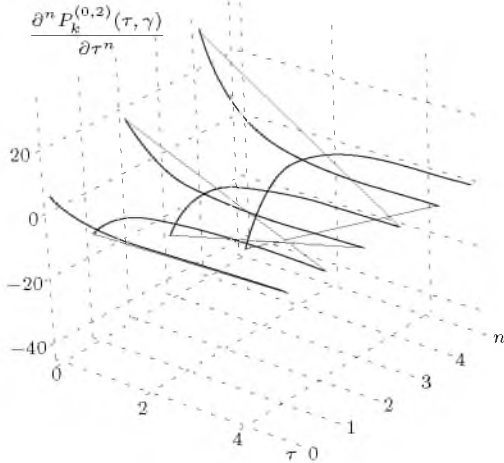

Рис. 1.62. Вид 1-ой производной ортогональных функций Якоби 2-ого порядка: а)  $\gamma = 0,25, c = 2, \alpha = 0, \beta \in [0; 5]$ ; б)  $\gamma \in (0; 2], c = 2, \alpha = 0, \beta = 1$

[1.63] 
$$\frac{\partial^2 P_k^{(0,\beta)}(\tau, \gamma)}{\partial \tau^2} = \frac{c^2 \gamma^2}{4} \sum_{s=0}^k \binom{k}{s} \binom{k+s+\beta}{s} \times (-1)^s (2s+1)^2 \exp(-2s+1)c\gamma\tau/2).$$

Частные случаи для 2-ой производной функций 0-5 порядков:

$$\frac{\partial^2 P_0^{(0,\beta)}(\tau, \gamma)}{\partial \tau^2} = \frac{c^2 \gamma^2}{4} \exp(-c\gamma\tau/2);$$

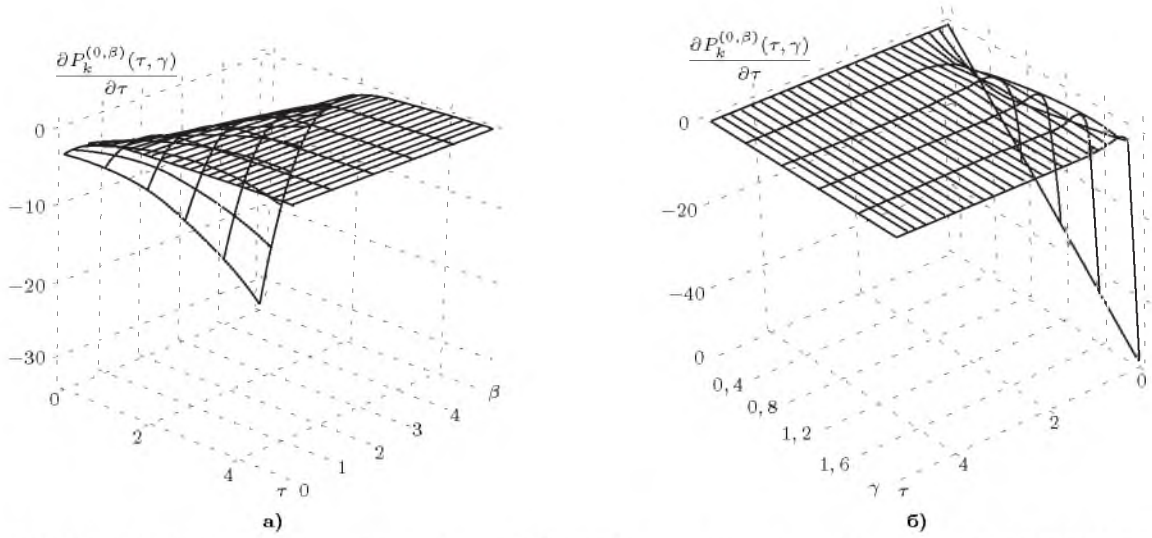
$$\frac{\partial^2 P_1^{(0,\beta)}(\tau, \gamma)}{\partial \tau^2} = \frac{c^2 \gamma^2}{4} \exp(-c\gamma\tau/2) (1 - 9(\beta+2) \exp(-c\gamma\tau));$$

$$\frac{\partial^2 P_2^{(0,\beta)}(\tau, \gamma)}{\partial \tau^2} = \frac{c^2 \gamma^2}{4} \exp(-c\gamma\tau/2) (1 - 18(\beta+3) \times$$

$$\times \exp(-c\gamma\tau) + 25(\beta+3)(\beta+4) \exp(-2c\gamma\tau/2));$$

$$\frac{\partial^2 P_3^{(0,\beta)}(\tau, \gamma)}{\partial \tau^2} = \frac{c^2 \gamma^2}{4} \exp(-c\gamma\tau/2) (1 - 27(\beta+4) \times \exp(-c\gamma\tau) + 75(\beta+4)(\beta+5) \exp(-2c\gamma\tau)/2 - 49(\beta+4)(\beta+5) \times (\beta+6) \exp(-3c\gamma\tau)/6);$$

$$\frac{\partial^2 P_4^{(0,\beta)}(\tau, \gamma)}{\partial \tau^2} = \frac{c^2 \gamma^2}{4} \exp(-c\gamma\tau/2) (1 - 36(\beta+5) \times$$

$$\times \exp(-c\gamma\tau) + 75(\beta+5)(\beta+6) \exp(-2c\gamma\tau) - 98(\beta+5)(\beta+6) \times (\beta+7) \exp(-3c\gamma\tau)/3 + 27(\beta+5)(\beta+6)(\beta+7)(\beta+8) \times \exp(-4c\gamma\tau)/8);$$

$$\frac{\partial^2 P_5^{(0,\beta)}(\tau, \gamma)}{\partial \tau^2} = \frac{c^2 \gamma^2}{4} \exp(-c\gamma\tau/2) (1 - 45(\beta+6) \exp(-c\gamma\tau) + 125(\beta+6)(\beta+7) \exp(-2c\gamma\tau) - 245(\beta+6)(\beta+7)(\beta+8) \times \exp(-3c\gamma\tau)/3 + 135(\beta+6)(\beta+7)(\beta+8)(\beta+9) \exp(-4c\gamma\tau)/8 - 121(\beta+6)(\beta+7)(\beta+8)(\beta+9)(\beta+10) \exp(-5c\gamma\tau)/120).$$



Рис. 1.63. Вид 2-ой производной ортогональных функций Якоби 2-ого порядка: а)  $\gamma = 0,25, c = 2, \alpha = 0, \beta \in [0; 5]$ ; б)  $\gamma \in (0; 2], c = 2, \alpha = 0, \beta = 1$

$$[1.64] \quad \frac{\partial^3 P_k^{(0,\beta)}(\tau, \gamma)}{\partial \tau^3} = -\frac{c^3 \gamma^3}{8} \sum_{s=0}^k \binom{k}{s} \binom{k+s+\beta}{s} \times \\ \times (-1)^s (2s+1)^3 \exp(-(2s+1)c\gamma\tau/2).$$

Частные случаи для 3-ой производной функций 0-5 порядков:

$$\frac{\partial^3 P_0^{(0,\beta)}(\tau, \gamma)}{\partial \tau^3} = -\frac{c^3 \gamma^3}{8} \exp(-c\gamma\tau/2);$$

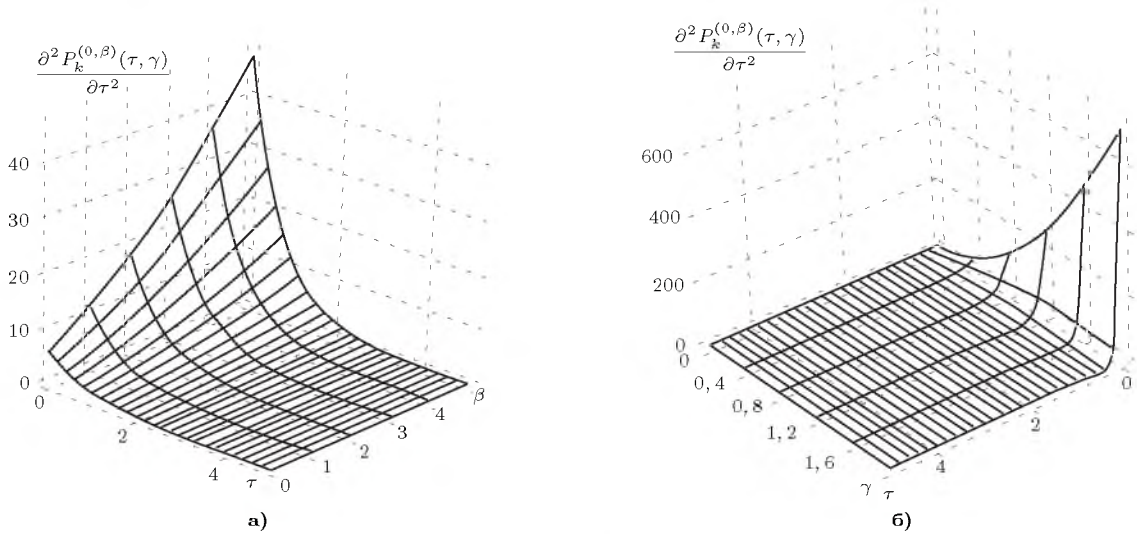
$$\frac{\partial^3 P_1^{(0,\beta)}(\tau, \gamma)}{\partial \tau^3} = -\frac{c^3 \gamma^3}{8} \exp(-c\gamma\tau/2) (1 - 27(\beta+2) \times$$

$\times \exp(-c\gamma\tau)$ );

$$\frac{\partial^3 P_2^{(0,\beta)}(\tau, \gamma)}{\partial \tau^3} = -\frac{c^3 \gamma^3}{8} \exp(-c\gamma\tau/2) (1 - 54(\beta+3) \times$$

$\times \exp(-c\gamma\tau) + 125(\beta+3)(\beta+4) \exp(-2c\gamma\tau/2)$ );

$$\frac{\partial^3 P_3^{(0,\beta)}(\tau, \gamma)}{\partial \tau^3} = -\frac{c^3 \gamma^3}{8} \exp(-c\gamma\tau/2) (1 - 81(\beta+4) \times$$

$\times \exp(-c\gamma\tau) + 375(\beta+4)(\beta+5) \exp(-2c\gamma\tau/2) - 343(\beta+4) \times$

$\times (\beta+5)(\beta+6) \exp(-3c\gamma\tau/6)$ );

$$\frac{\partial^3 P_4^{(0,\beta)}(\tau, \gamma)}{\partial \tau^3} = -\frac{c^3 \gamma^3}{8} \exp(-c\gamma\tau/2) (1 - 108(\beta+5) \times$$

$\times \exp(-c\gamma\tau) + 375(\beta+5)(\beta+6) \exp(-2c\gamma\tau) - 686(\beta+5) \times$

$\times (\beta+6)(\beta+7) \exp(-3c\gamma\tau/3) + 243(\beta+5)(\beta+6)(\beta+7)(\beta+8) \times$

$\times \exp(-4c\gamma\tau/8)$ );

$$\frac{\partial^3 P_5^{(0,\beta)}(\tau, \gamma)}{\partial \tau^3} = -\frac{c^3 \gamma^3}{8} \exp(-c\gamma\tau/2) (1 - 135(\beta+6) \times$$

$\times \exp(-c\gamma\tau) + 625(\beta+6)(\beta+7) \exp(-2c\gamma\tau) - 1715(\beta+6) \times$

$\times (\beta+7)(\beta+8) \exp(-3c\gamma\tau/3) + 1215(\beta+6)(\beta+7)(\beta+8)(\beta+9) \times$

$\times \exp(-4c\gamma\tau/8) - 1331(\beta+6)(\beta+7)(\beta+8)(\beta+9)(\beta+10) \times$

$\times \exp(-5c\gamma\tau/120)$ ).



Рис. 1.64. Вид 3-ой производной ортогональных функций Якоби 2-ого порядка: а)  $\gamma = 0,25$ ,  $c = 2$ ,  $\alpha = 0$ ,  $\beta \in [0; 5]$ ; б)  $\gamma \in (0; 2]$ ,  $c = 2$ ,  $\alpha = 0$ ,  $\beta = 1$

$$[1.65] \quad \frac{\partial^n P_k^{(0,\beta)}(\tau, \gamma)}{\partial \tau^n} = \left(-\frac{c\gamma}{2}\right)^n \sum_{s=0}^k \binom{k}{s} \binom{k+s+\beta}{s} \times \\ \times (-1)^s (2s+1)^n \exp(-(2s+1)c\gamma\tau/2).$$

Частные случаи для n-ой производной функций 0-5 порядков:

$$\frac{\partial^n P_0^{(0,\beta)}(\tau, \gamma)}{\partial \tau^n} = \left(-\frac{c\gamma}{2}\right)^n \exp(-c\gamma\tau/2);$$

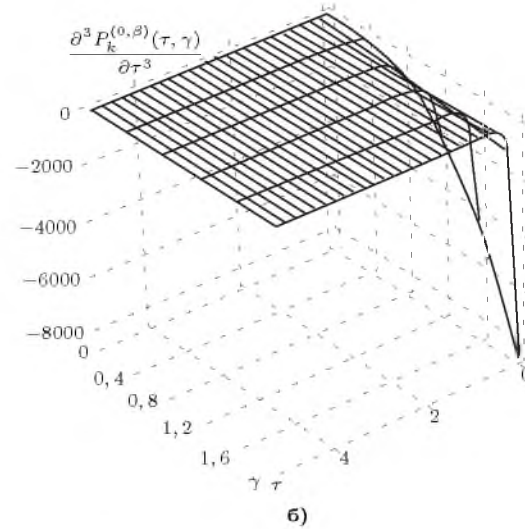
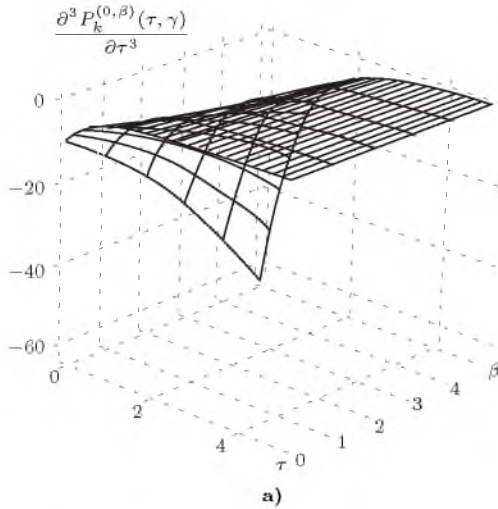
$$\frac{\partial^n P_1^{(0,\beta)}(\tau, \gamma)}{\partial \tau^n} = \left(-\frac{c\gamma}{2}\right)^n \exp(-c\gamma\tau/2) (1 - 3^n(\beta+2) \times$$

$\times \exp(-c\gamma\tau)$ );

$$\frac{\partial^n P_2^{(0,\beta)}(\tau, \gamma)}{\partial \tau^n} = \left(-\frac{c\gamma}{2}\right)^n \exp(-c\gamma\tau/2) (1 - 2 \cdot 3^n(\beta+3) \times$$

$\times \exp(-c\gamma\tau) + 5^n(\beta+3)(\beta+4) \exp(-2c\gamma\tau/2)$ );

$$\frac{\partial^n P_3^{(0,\beta)}(\tau, \gamma)}{\partial \tau^n} = \left(-\frac{c\gamma}{2}\right)^n \exp(-c\gamma\tau/2) (1 - 3 \cdot 3^n(\beta+4) \times$$

$\times \exp(-c\gamma\tau) + 3 \cdot 5^n(\beta+4) \times$

$\times (\beta+5) \exp(-2c\gamma\tau/2) - 7^n(\beta+4)(\beta+5)(\beta+6) \exp(-3c\gamma\tau/6)$ );

$$\frac{\partial^n P_4^{(0,\beta)}(\tau, \gamma)}{\partial \tau^n} = \left(-\frac{c\gamma}{2}\right)^n \exp(-c\gamma\tau/2) (1 - 4 \cdot 3^n(\beta+5) \times$$

$\times \exp(-c\gamma\tau) + 3 \cdot 5^n(\beta+5)(\beta+6) \exp(-2c\gamma\tau) - 2 \cdot 7^n(\beta+5) \times$

$\times (\beta+6)(\beta+7) \exp(-3c\gamma\tau/3) + 9^n(\beta+5)(\beta+6)(\beta+7)(\beta+8) \times$

$\times \exp(-4c\gamma\tau/24)$ );

$$\frac{\partial^n P_5^{(0,\beta)}(\tau, \gamma)}{\partial \tau^n} = \left(-\frac{c\gamma}{2}\right)^n \exp(-c\gamma\tau/2) (1 - 5 \cdot 3^n(\beta+6) \times$$

$\times \exp(-c\gamma\tau) + 5 \cdot 5^n(\beta+6)(\beta+7) \exp(-2c\gamma\tau) - 5 \cdot 7^n(\beta+6) \times$

$\times (\beta+7)(\beta+8) \exp(-3c\gamma\tau) + 5 \cdot 9^n(\beta+6)(\beta+7)(\beta+8)(\beta+9) \times$

$\times \exp(-4c\gamma\tau) - 11^n(\beta+6)(\beta+7)(\beta+8)(\beta+9)(\beta+10) \times$

$\times \exp(-5c\gamma\tau/120)$ ).





Рис. 1.65. Вид n-ой производной ортогональных функций Якоби 2-ого порядка: а)  $n = 0.5, \gamma = 0,25, c = 2, \alpha = 0, \beta \in [0; 5]$ ; б)  $n = 0.5, \gamma \in (0; 2], c = 2, \alpha = 0, \beta = 1$

### 1.3 Аналитические соотношения для неопределенных интегралов от ортогональных функций

$$[1.66] \quad \int L_k(\tau, \gamma) d\tau = -\frac{2}{\gamma} \exp\left(-\frac{\gamma\tau}{2}\right) \sum_{s=0}^k \binom{k}{s} (-\gamma)^s \times \\ \times \sum_{j=0}^s \left(\frac{2}{\gamma}\right)^j \frac{\tau^{s-j}}{(s-j)!}.$$

Частные случаи для неопределенного интеграла от функций 0-5 порядков:

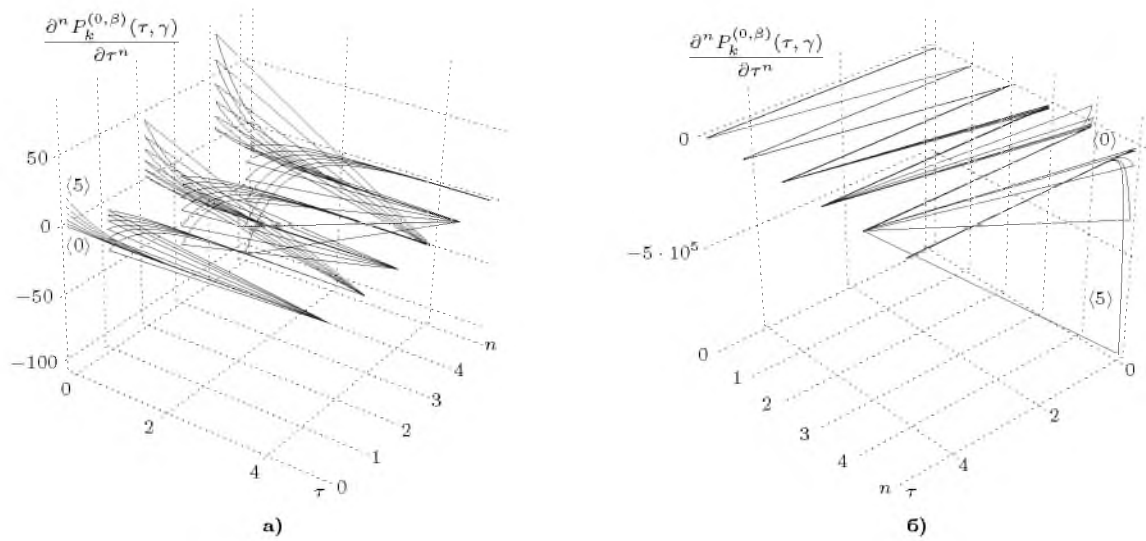
$$\begin{aligned} \int L_0(\tau, \gamma) d\tau &= -\frac{2}{\gamma} \exp\left(-\frac{\gamma\tau}{2}\right); \\ \int L_1(\tau, \gamma) d\tau &= \frac{2}{\gamma} \exp\left(-\frac{\gamma\tau}{2}\right) (\gamma\tau + 1); \\ \int L_2(\tau, \gamma) d\tau &= -\frac{1}{\gamma} \exp\left(-\frac{\gamma\tau}{2}\right) (\gamma^2\tau^2 + 2); \\ \int L_3(\tau, \gamma) d\tau &= \frac{1}{3\gamma} \exp\left(-\frac{\gamma\tau}{2}\right) (\gamma^3\tau^3 - 3\gamma^2\tau^2 + 6\gamma\tau + 6); \\ \int L_4(\tau, \gamma) d\tau &= -\frac{1}{12\gamma} \exp\left(-\frac{\gamma\tau}{2}\right) (\gamma^4\tau^4 - 8\gamma^3\tau^3 + 24\gamma^2\tau^2 + \\ &+ 24); \\ \int L_5(\tau, \gamma) d\tau &= \frac{1}{60\gamma} \exp\left(-\frac{\gamma\tau}{2}\right) (\gamma^5\tau^5 - 15\gamma^4\tau^4 + 80\gamma^3\tau^3 - \\ &- 120\gamma^2\tau^2 + 120\gamma\tau + 120). \end{aligned}$$



Рис. 1.66. Вид неопределенного интеграла от ортогональных функций Лагерра 0-5 порядков;  $\gamma = 8$

$$[1.67] \quad \int \tau L_k(\tau, \gamma) d\tau = -\frac{2}{\gamma} \exp\left(-\frac{\gamma\tau}{2}\right) \sum_{s=0}^k \binom{k}{s} (-\gamma)^s \times \\ \times (s+1) \sum_{j=0}^{s+1} \left(\frac{2}{\gamma}\right)^j \frac{\tau^{s+1-j}}{(s+1-j)!}.$$

Частные случаи для неопределенного интеграла 1-ого рода от функций 0-5 порядков:

$$\begin{aligned} \int \tau L_0(\tau, \gamma) d\tau &= -\frac{2}{\gamma^2} \exp\left(-\frac{\gamma\tau}{2}\right) (\gamma\tau + 2); \\ \int \tau L_1(\tau, \gamma) d\tau &= \frac{2}{\gamma^2} \exp\left(-\frac{\gamma\tau}{2}\right) (\gamma^2\tau^2 + 3\gamma\tau + 6); \\ \int \tau L_2(\tau, \gamma) d\tau &= -\frac{1}{\gamma^2} \exp\left(-\frac{\gamma\tau}{2}\right) (\gamma^3\tau^3 + 2\gamma^2\tau^2 + 10\gamma\tau + \\ &+ 20); \\ \int \tau L_3(\tau, \gamma) d\tau &= \frac{1}{3\gamma^2} \exp\left(-\frac{\gamma\tau}{2}\right) (\gamma^4\tau^4 - \gamma^3\tau^3 + 12\gamma^2\tau^2 + \\ &+ 42\gamma\tau + 84); \\ \int \tau L_4(\tau, \gamma) d\tau &= -\frac{1}{12\gamma^2} \exp\left(-\frac{\gamma\tau}{2}\right) (\gamma^5\tau^5 - 6\gamma^4\tau^4 + 24\gamma^3\tau^3 + \end{aligned}$$

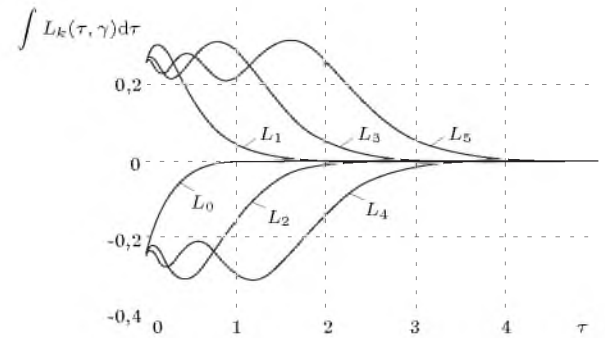

Рис. 1.67. Вид неопределенного интеграла 1-ого рода от ортогональных функций Лагерра 0-5 порядков;  $\gamma = 8$

$$[1.68] \quad \int \tau^2 L_k(\tau, \gamma) d\tau = -\frac{2}{\gamma} \exp\left(-\frac{\gamma\tau}{2}\right) \sum_{s=0}^k \binom{k}{s} (-\gamma)^s \times \\ \times (s+1)(s+2) \sum_{j=0}^{s+2} \left(\frac{2}{\gamma}\right)^j \frac{\tau^{s+2-j}}{(s+2-j)!}.$$

Частные случаи для неопределенного интеграла 2-ого рода от функций 0-5 порядков:

$$\int \tau^2 L_0(\tau, \gamma) d\tau = -\frac{2}{\gamma^3} \exp\left(-\frac{\gamma\tau}{2}\right) (\gamma^2\tau^2 + 4\gamma\tau + 8);$$

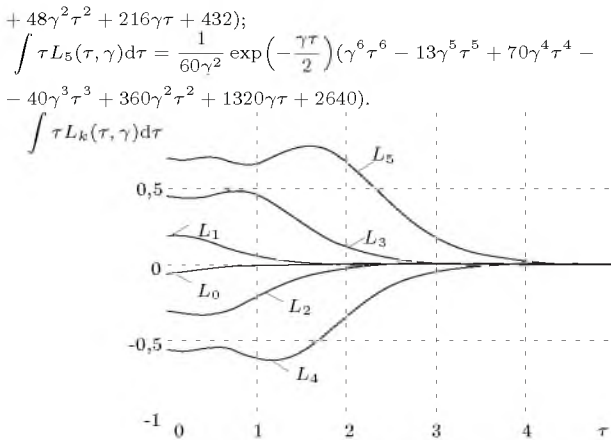
$$\int \tau^2 L_1(\tau, \gamma) d\tau = \frac{2}{\gamma^3} \exp\left(-\frac{\gamma\tau}{2}\right) (\gamma^3\tau^3 + 5\gamma^2\tau^2 + 20\gamma\tau + 40);$$

$$\int \tau^2 L_2(\tau, \gamma) d\tau = -\frac{1}{\gamma^3} \exp\left(-\frac{\gamma\tau}{2}\right) (\gamma^4\tau^4 + 4\gamma^3\tau^3 + 26\gamma^2\tau^2 +$$
 $+ 104\gamma\tau + 208);$ 

$$\int \tau^2 L_3(\tau, \gamma) d\tau = \frac{1}{\gamma^3} \exp\left(-\frac{\gamma\tau}{2}\right) (\gamma^5\tau^5 + \gamma^4\tau^4 + 26\gamma^3\tau^3 +$$
 $+ 150\gamma^2\tau^2 + 600\gamma\tau + 1200);$ 

$$\int \tau^2 L_4(\tau, \gamma) d\tau = -\frac{1}{12\gamma^3} \exp\left(-\frac{\gamma\tau}{2}\right) (\gamma^6\tau^6 - 4\gamma^5\tau^5 + 32 \times$$
 $\times \gamma^4\tau^4 + 160\gamma^3\tau^3 + 984\gamma^2\tau^2 + 3936\gamma\tau + 7872);$ 

$$\int \tau^2 L_5(\tau, \gamma) d\tau = \frac{\gamma^3}{960} \exp\left(-\frac{\gamma\tau}{2}\right) (\gamma^7\tau^7 - 11\gamma^6\tau^6 - 68\gamma^5\tau^5 +$$
 $+ 80\gamma^4\tau^4 + 1240\gamma^3\tau^3 + 7320\gamma^2\tau^2 + 29280\gamma\tau + 58560).$ 

$$\int \tau^2 L_k(\tau, \gamma) d\tau$$



Рис. 1.68. Вид неопределенного интеграла 2-ого рода от ортогональных функций Лагерра 0-5 порядков;  $\gamma = 8$

$$[1.69] \quad \int \tau^3 L_k(\tau, \gamma) d\tau = -\frac{2}{\gamma} \exp\left(-\frac{\gamma\tau}{2}\right) \sum_{s=0}^k \binom{k}{s} (-\gamma)^s \times \\ \times (s+1)(s+2)(s+3) \sum_{j=0}^{s+3} \left(\frac{2}{\gamma}\right)^j \frac{\tau^{s+3-j}}{(s+3-j)!}.$$

Частные случаи для неопределенного интеграла 3-ого рода от функций 0-5 порядков:

$$\int \tau^3 L_0(\tau, \gamma) d\tau = -\frac{2}{\gamma^4} \exp\left(-\frac{\gamma\tau}{2}\right) (\gamma^3\tau^3 + 6\gamma^2\tau^2 + 24\gamma\tau + 48);$$

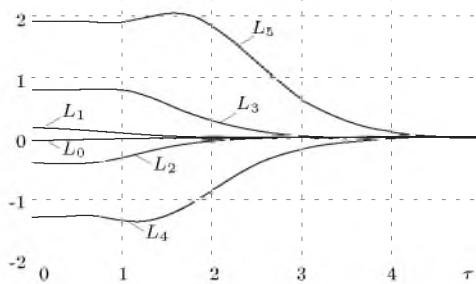
$$\int \tau^3 L_1(\tau, \gamma) d\tau = \frac{2}{\gamma^4} \exp\left(-\frac{\gamma\tau}{2}\right) (\gamma^4\tau^4 + 7\gamma^3\tau^3 + 42\gamma^2\tau^2 +$$
 $+ 168\gamma\tau + 336);$ 

$$\int \tau^3 L_2(\tau, \gamma) d\tau = -\frac{1}{\gamma^4} \exp\left(-\frac{\gamma\tau}{2}\right) (\gamma^5\tau^5 + 6\gamma^4\tau^4 + 50\gamma^3\tau^3 +$$
 $+ 300\gamma^2\tau^2 + 1200\gamma\tau + 2400);$ 

$$\int \tau^3 L_3(\tau, \gamma) d\tau = \frac{1}{3\gamma^4} \exp\left(-\frac{\gamma\tau}{2}\right) (\gamma^6\tau^6 + 3\gamma^5\tau^5 + 48\gamma^4\tau^4 +$$
 $+ 378\gamma^3\tau^3 + 2268\gamma^2\tau^2 + 9072\gamma\tau + 18144);$ 

$$\int \tau^3 L_4(\tau, \gamma) d\tau = -\frac{1}{12\gamma^4} \exp\left(-\frac{\gamma\tau}{2}\right) (\gamma^7\tau^7 - 2\gamma^6\tau^6 + 48 \times$$
 $\times \gamma^5\tau^5 + 384\gamma^4\tau^4 + 3096\gamma^3\tau^3 + 18576\gamma^2\tau^2 + 74304\gamma\tau + 148608);$ 

$$\int \tau^3 L_5(\tau, \gamma) d\tau = \frac{1}{60\gamma^4} \exp\left(-\frac{\gamma\tau}{2}\right) (\gamma^8\tau^8 - 9\gamma^7\tau^7 + 74\gamma^6\tau^6 +$$
 $+ 288\gamma^5\tau^5 + 3480\gamma^4\tau^4 + 27720\gamma^3\tau^3 + 166320\gamma^2\tau^2 + 665280\gamma\tau +$ 
 $+ 1330560).$



Рис. 1.69. Вид неопределенного интеграла 3-ого рода от ортогональных функций Лагерра 0-5 порядков;  $\gamma = 8$

$$[1.70] \quad \int \tau^n L_k(\tau, \gamma) d\tau = -\frac{2}{\gamma} \exp\left(-\frac{\gamma\tau}{2}\right) \sum_{s=0}^k \binom{k}{s} (-\gamma)^s \times \\ \times \frac{(s+n)!}{s!} \sum_{j=0}^{s+n} \left(\frac{2}{\gamma}\right)^j \frac{\tau^{s+n-j}}{(s+n-j)!}.$$

Частные случаи для неопределенного интеграла n-ого рода от функций 0-5 порядков:

$$\int \tau^n L_0(\tau, \gamma) d\tau = -\frac{2n!}{\gamma} \exp\left(-\frac{\gamma\tau}{2}\right) \sum_{j=0}^n \left(\frac{2}{\gamma}\right)^j \frac{\tau^{n-j}}{(n-j)!};$$

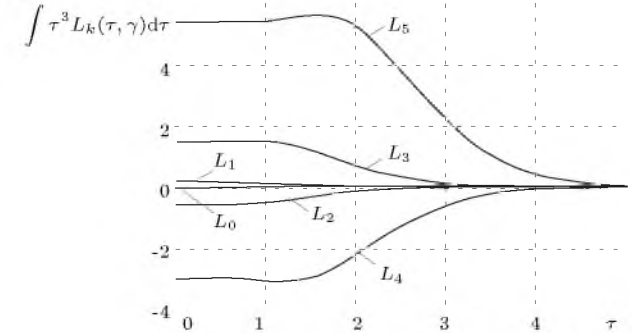
$$\int \tau^n L_1(\tau, \gamma) d\tau = -\frac{2}{\gamma} \exp\left(-\frac{\gamma\tau}{2}\right) \left( n! \sum_{j=0}^n \left(\frac{2}{\gamma}\right)^j \frac{\tau^{n-j}}{(n-j)!} -$$
 $- \gamma(n+1)! \sum_{j=0}^{n+1} \left(\frac{2}{\gamma}\right)^j \frac{\tau^{1+n-j}}{(1+n-j)!} \right);$

$$\int \tau^n L_2(\tau, \gamma) d\tau = -\frac{2}{\gamma} \exp\left(-\frac{\gamma\tau}{2}\right) \left( n! \sum_{j=0}^n \left(\frac{2}{\gamma}\right)^j \frac{\tau^{n-j}}{(n-j)!} - 2\gamma(n+1)! \sum_{j=0}^{n+1} \left(\frac{2}{\gamma}\right)^j \frac{\tau^{1+n-j}}{(1+n-j)!} + \frac{1}{2}\gamma^2(n+2)! \times \sum_{j=0}^{n+2} \left(\frac{2}{\gamma}\right)^j \frac{\tau^{2+n-j}}{(2+n-j)!} \right);$$

$$\int \tau^n L_3(\tau, \gamma) d\tau = -\frac{2}{\gamma} \exp\left(-\frac{\gamma\tau}{2}\right) \left( n! \sum_{j=0}^n \left(\frac{2}{\gamma}\right)^j \frac{\tau^{n-j}}{(n-j)!} - 3\gamma(n+1)! \sum_{j=0}^{n+1} \left(\frac{2}{\gamma}\right)^j \frac{\tau^{1+n-j}}{(1+n-j)!} + \frac{3}{2}\gamma^2(n+2)! \times \sum_{j=0}^{n+2} \left(\frac{2}{\gamma}\right)^j \frac{\tau^{2+n-j}}{(2+n-j)!} - \frac{1}{6}\gamma^3(n+3)! \sum_{j=0}^{n+3} \left(\frac{2}{\gamma}\right)^j \frac{\tau^{3+n-j}}{(3+n-j)!} \right);$$

$$\int \tau^n L_4(\tau, \gamma) d\tau = -\frac{2}{\gamma} \exp\left(-\frac{\gamma\tau}{2}\right) \left( n! \sum_{j=0}^n \left(\frac{2}{\gamma}\right)^j \frac{\tau^{n-j}}{(n-j)!} - 4\gamma(n+1)! \sum_{j=0}^{n+1} \left(\frac{2}{\gamma}\right)^j \frac{\tau^{1+n-j}}{(1+n-j)!} + 3\gamma^2(n+2)! \times \sum_{j=0}^{n+2} \left(\frac{2}{\gamma}\right)^j \frac{\tau^{2+n-j}}{(2+n-j)!} - \frac{2}{3}\gamma^3(n+3)! \sum_{j=0}^{n+3} \left(\frac{2}{\gamma}\right)^j \frac{\tau^{3+n-j}}{(3+n-j)!} + \frac{1}{24}\gamma^4(n+4)! \sum_{j=0}^{n+4} \left(\frac{2}{\gamma}\right)^j \frac{\tau^{4+n-j}}{(4+n-j)!} \right);$$

$$\int \tau^n L_5(\tau, \gamma) d\tau = -\frac{2}{\gamma} \exp\left(-\frac{\gamma\tau}{2}\right) \left( n! \sum_{j=0}^n \left(\frac{2}{\gamma}\right)^j \frac{\tau^{n-j}}{(n-j)!} - 5\gamma(n+1)! \sum_{j=0}^{n+1} \left(\frac{2}{\gamma}\right)^j \frac{\tau^{1+n-j}}{(1+n-j)!} + 5\gamma^2(n+2)! \times \sum_{j=0}^{n+2} \left(\frac{2}{\gamma}\right)^j \frac{\tau^{2+n-j}}{(2+n-j)!} - \frac{5}{3}\gamma^3(n+3)! \sum_{j=0}^{n+3} \left(\frac{2}{\gamma}\right)^j \frac{\tau^{3+n-j}}{(3+n-j)!} + \frac{5}{24}\gamma^4(n+4)! \sum_{j=0}^{n+4} \left(\frac{2}{\gamma}\right)^j \frac{\tau^{4+n-j}}{(4+n-j)!} - \frac{1}{120}\gamma^5(n+5)! \times \sum_{j=0}^{n+5} \left(\frac{2}{\gamma}\right)^j \frac{\tau^{5+n-j}}{(5+n-j)!} \right).$$



Рис. 1.70. Вид неопределенного интеграла n-ого рода от ортогональных функций Лагерра 2-ого порядка;  $n = 0..5$ ,  $\gamma = 8$

$$[1.71] \quad \int L_k^{(1)}(\tau, \gamma) d\tau = -\frac{2}{\gamma} \exp\left(-\frac{\gamma\tau}{2}\right) \sum_{s=0}^k \binom{k+1}{k-s} \times (-\gamma)^s \sum_{j=0}^s \left(\frac{2}{\gamma}\right)^j \frac{\tau^{s-j}}{(s-j)!}.$$

Частные случаи для неопределенного интеграла от функций 0-5 порядков:

$$\int L_0^{(1)}(\tau, \gamma) d\tau = -\frac{2}{\gamma} \exp\left(-\frac{\gamma\tau}{2}\right);$$

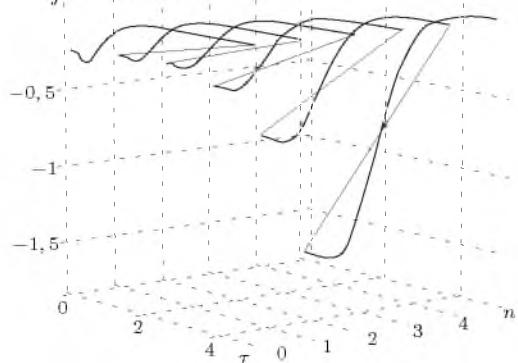
$$\int L_1^{(1)}(\tau, \gamma) d\tau = 2 \exp\left(-\frac{\gamma\tau}{2}\right) \tau;$$

$$\int L_2^{(1)}(\tau, \gamma) d\tau = -\frac{1}{\gamma} \exp\left(-\frac{\gamma\tau}{2}\right) (\gamma^2 \tau^2 - 2\gamma\tau + 2);$$

$$\int L_3^{(1)}(\tau, \gamma) d\tau = \frac{1}{3} \exp\left(-\frac{\gamma\tau}{2}\right) \tau (\gamma^2 \tau^2 - 6\gamma\tau + 12);$$

$$\int L_4^{(1)}(\tau, \gamma) d\tau = -\frac{1}{12\gamma} \exp\left(-\frac{\gamma\tau}{2}\right) (\gamma^4 \tau^4 - 12\gamma^3 \tau^3 + 48\gamma^2 \tau^2 - 48\gamma\tau + 24);$$

$$\int L_5^{(1)}(\tau, \gamma) d\tau = \frac{1}{60} \exp\left(-\frac{\gamma\tau}{2}\right) \tau (\gamma^4 \tau^4 - 20\gamma^3 \tau^3 + 140\gamma^2 \tau^2 - 360\gamma\tau + 360).$$



Рис. 1.71. Вид неопределенного интеграла от ортогональных функций Сонина-Лагерра 0-5 порядков;  $\gamma = 8$ ,  $\alpha = 1$

$$[1.72] \quad \int \tau L_k^{(1)}(\tau, \gamma) d\tau = -\frac{2}{\gamma} \exp\left(-\frac{\gamma\tau}{2}\right) \sum_{s=0}^k \binom{k+1}{k-s} \times (-\gamma)^s (s+1) \sum_{j=0}^{s+1} \left(\frac{2}{\gamma}\right)^j \frac{\tau^{s+1-j}}{(s+1-j)!}.$$

Частные случаи для неопределенного интеграла 1-ого рода от функций 0-5 порядков:

$$\int \tau L_0^{(1)}(\tau, \gamma) d\tau = -\frac{2}{\gamma^2} \exp\left(-\frac{\gamma\tau}{2}\right) (\gamma\tau + 2);$$

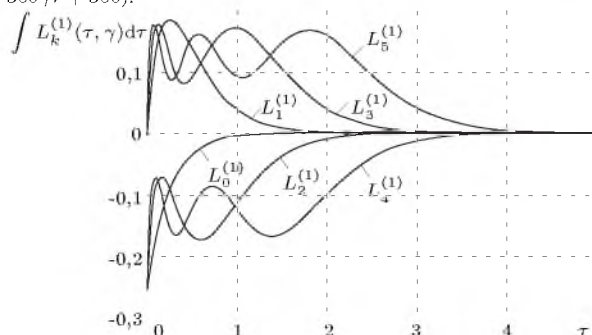
$$\int \tau L_1^{(1)}(\tau, \gamma) d\tau = \frac{2}{\gamma^2} \exp\left(-\frac{\gamma\tau}{2}\right) (\gamma^2 \tau^2 + 2\gamma\tau + 4);$$

$$\int \tau L_2^{(1)}(\tau, \gamma) d\tau = -\frac{1}{\gamma^2} \exp\left(-\frac{\gamma\tau}{2}\right) (\gamma^3 \tau^3 + 6\gamma\tau + 12);$$

$$\int \tau L_3^{(1)}(\tau, \gamma) d\tau = \frac{1}{3\gamma^2} \exp\left(-\frac{\gamma\tau}{2}\right) (\gamma^4 \tau^4 - 4\gamma^3 \tau^3 + 12\gamma^2 \tau^2 + 24\gamma\tau + 48);$$

$$\int \tau L_4^{(1)}(\tau, \gamma) d\tau = -\frac{1}{12\gamma^2} \exp\left(-\frac{\gamma\tau}{2}\right) (\gamma^5 \tau^5 - 10\gamma^4 \tau^4 + 40 \times \gamma^3 \tau^3 + 120\gamma\tau + 240);$$

$$\int \tau L_5^{(1)}(\tau, \gamma) d\tau = \frac{1}{60\gamma^2} \exp\left(-\frac{\gamma\tau}{2}\right) (\gamma^6 \tau^6 - 18\gamma^5 \tau^5 + 120 \times \gamma^4 \tau^4 - 240\gamma^3 \tau^3 + 360\gamma^2 \tau^2 + 720\gamma\tau + 1440).$$



Рис. 1.72. Вид неопределенного интеграла 1-ого рода от ортогональных функций Сонина-Лагерра 0-5 порядков;  $\gamma = 8, \alpha = 1$

$$[1.73] \quad \int \tau^2 L_k^{(1)}(\tau, \gamma) d\tau = -\frac{2}{\gamma} \exp\left(-\frac{\gamma\tau}{2}\right) \sum_{s=0}^k \binom{k+1}{k-s} \times (-\gamma)^s (s+1)(s+2) \sum_{j=0}^{s+2} \left(\frac{2}{\gamma}\right)^j \frac{\tau^{s+2-j}}{(s+2-j)!}$$

Частные случаи для неопределенного интеграла 2-ого рода от функций 0-5 порядков:

$$\begin{aligned} \int \tau^2 L_0^{(1)}(\tau, \gamma) d\tau &= -\frac{2}{\gamma^3} \exp\left(-\frac{\gamma\tau}{2}\right) (\gamma^2 \tau^2 + 4\gamma\tau + 8); \\ \int \tau^2 L_1^{(1)}(\tau, \gamma) d\tau &= \frac{2}{\gamma^3} \exp\left(-\frac{\gamma\tau}{2}\right) (\gamma^3 \tau^3 + 4\gamma^2 \tau^2 + 16\gamma\tau + 32); \\ \int \tau^2 L_2^{(1)}(\tau, \gamma) d\tau &= -\frac{1}{\gamma^3} \exp\left(-\frac{\gamma\tau}{2}\right) (\gamma^4 \tau^4 + 2\gamma^3 \tau^3 + 18\gamma^2 \tau^2 + 72\gamma\tau + 144); \\ \int \tau^2 L_3^{(1)}(\tau, \gamma) d\tau &= \frac{1}{\gamma^3} \exp\left(-\frac{\gamma\tau}{2}\right) (\gamma^5 \tau^5 - 2\gamma^4 \tau^4 + 20\gamma^3 \tau^3 + 96\gamma^2 \tau^2 + 384\gamma\tau + 768); \\ \int \tau^2 L_4^{(1)}(\tau, \gamma) d\tau &= -\frac{1}{12\gamma^3} \exp\left(-\frac{\gamma\tau}{2}\right) (\gamma^6 \tau^6 - 8\gamma^5 \tau^5 + 40 \times \\ &\times \gamma^4 \tau^4 + 80\gamma^3 \tau^3 + 600\gamma^2 \tau^2 + 2400\gamma\tau + 4800); \\ \int \tau^2 L_5^{(1)}(\tau, \gamma) d\tau &= \frac{\gamma^3}{960} \exp\left(-\frac{\gamma\tau}{2}\right) (\gamma^7 \tau^7 - 16\gamma^6 \tau^6 + 108 \times \\ &\times \gamma^5 \tau^5 - 120\gamma^4 \tau^4 + 840\gamma^3 \tau^3 + 4320\gamma^2 \tau^2 + 17280\gamma\tau + 34560). \end{aligned}$$

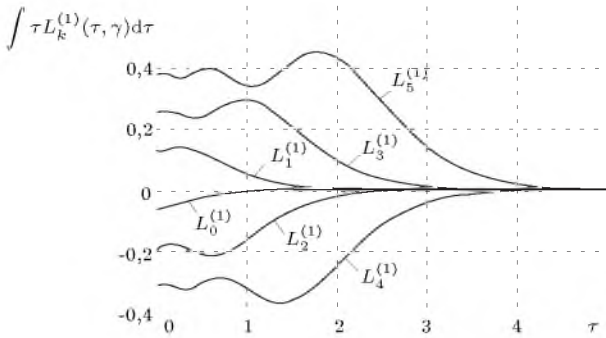

Рис. 1.73. Вид неопределенного интеграла 2-ого рода от ортогональных функций Сонина-Лагерра 0-5 порядков;  $\gamma = 8, \alpha = 1$

$$[1.74] \quad \int \tau^3 L_k^{(1)}(\tau, \gamma) d\tau = -\frac{2}{\gamma} \exp\left(-\frac{\gamma\tau}{2}\right) \sum_{s=0}^k \binom{k+1}{k-s} \times (-\gamma)^s (s+1)(s+2)(s+3) \sum_{j=0}^{s+3} \left(\frac{2}{\gamma}\right)^j \frac{\tau^{s+3-j}}{(s+3-j)!}$$

Частные случаи для неопределенного интеграла 3-ого рода от функций 0-5 порядков:

$$\begin{aligned} \int \tau^3 L_0^{(1)}(\tau, \gamma) d\tau &= -\frac{2}{\gamma^4} \exp\left(-\frac{\gamma\tau}{2}\right) (\gamma^3 \tau^3 + 6\gamma^2 \tau^2 + 24\gamma\tau + 48); \\ \int \tau^3 L_1^{(1)}(\tau, \gamma) d\tau &= \frac{2}{\gamma^4} \exp\left(-\frac{\gamma\tau}{2}\right) (\gamma^4 \tau^4 + 6\gamma^3 \tau^3 + 36\gamma^2 \tau^2 + 144\gamma\tau + 288); \\ \int \tau^3 L_2^{(1)}(\tau, \gamma) d\tau &= -\frac{1}{\gamma^4} \exp\left(-\frac{\gamma\tau}{2}\right) (\gamma^5 \tau^5 + 4\gamma^4 \tau^4 + 38\gamma^3 \tau^3 + 228\gamma^2 \tau^2 + 912\gamma\tau + 1824); \\ \int \tau^3 L_3^{(1)}(\tau, \gamma) d\tau &= \frac{1}{3\gamma^4} \exp\left(-\frac{\gamma\tau}{2}\right) (\gamma^6 \tau^6 + 36\gamma^4 \tau^4 + 264 \times \\ &\times \gamma^3 \tau^3 + 1584\gamma^2 \tau^2 + 6336\gamma\tau + 12672); \\ \int \tau^3 L_4^{(1)}(\tau, \gamma) d\tau &= -\frac{1}{12\gamma^4} \exp\left(-\frac{\gamma\tau}{2}\right) (\gamma^7 \tau^7 - 6\gamma^6 \tau^6 + 48 \times \\ &\times \gamma^5 \tau^5 + 240\gamma^4 \tau^4 + 2040\gamma^3 \tau^3 + 12240\gamma^2 \tau^2 + 48960\gamma\tau + 97920); \\ \int \tau^3 L_5^{(1)}(\tau, \gamma) d\tau &= \frac{1}{60\gamma^4} \exp\left(-\frac{\gamma\tau}{2}\right) (\gamma^8 \tau^8 - 14\gamma^7 \tau^7 + 104 \times \\ &\times \gamma^6 \tau^6 + 48\gamma^5 \tau^5 + 2280\gamma^4 \tau^4 + 17520\gamma^3 \tau^3 + 105120\gamma^2 \tau^2 + 420480\gamma\tau + 840960). \end{aligned}$$

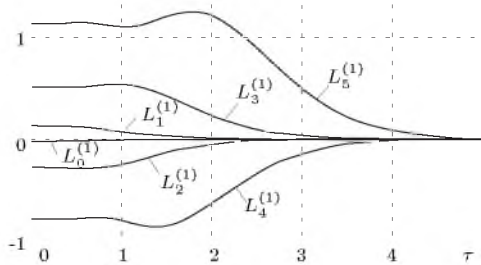

Рис. 1.74. Вид неопределенного интеграла 3-ого рода от ортогональных функций Сонина-Лагерра 0-5 порядков;  $\gamma = 8, \alpha = 1$

$$[1.75] \quad \int \tau^n L_k^{(1)}(\tau, \gamma) d\tau = -\frac{2}{\gamma} \exp\left(-\frac{\gamma\tau}{2}\right) \sum_{s=0}^k \binom{k+1}{k-s} \times (-\gamma)^s \frac{(s+n)!}{s!} \sum_{j=0}^{s+n} \left(\frac{2}{\gamma}\right)^j \frac{\tau^{s+n-j}}{(s+n-j)!}$$

Частные случаи для неопределенного интеграла n-ого рода от функций 0-5 порядков:

$$\begin{aligned} \int \tau^n L_0^{(1)}(\tau, \gamma) d\tau &= -\frac{2n!}{\gamma} \exp\left(-\frac{\gamma\tau}{2}\right) \sum_{j=0}^n \left(\frac{2}{\gamma}\right)^j \frac{\tau^{n-j}}{(n-j)!}; \\ \int \tau^n L_1^{(1)}(\tau, \gamma) d\tau &= -\frac{2}{\gamma} \exp\left(-\frac{\gamma\tau}{2}\right) \left( n! \sum_{j=0}^n \left(\frac{2}{\gamma}\right)^j \frac{\tau^{n-j}}{(n-j)!} - \right. \end{aligned}$$

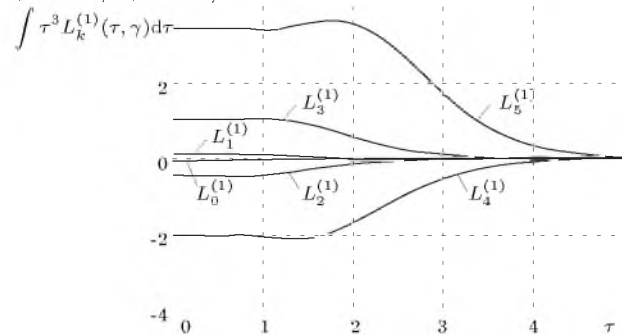
$$\int \tau^n L_5^{(1)}(\tau, \gamma) d\tau = -\frac{2}{\gamma} \exp\left(-\frac{\gamma\tau}{2}\right) \left( n! \sum_{j=0}^n \left(\frac{2}{\gamma}\right)^j \frac{\tau^{n-j}}{(n-j)!} - 6\gamma(n+1)! \sum_{j=0}^{n+1} \left(\frac{2}{\gamma}\right)^j \frac{\tau^{1+n-j}}{(1+n-j)!} + \frac{15}{2} \gamma^2 (n+2)! \times \right. \\ \left. + \sum_{j=0}^{n+2} \left(\frac{2}{\gamma}\right)^j \frac{\tau^{2+n-j}}{(2+n-j)!} - \frac{10}{3} \gamma^3 (n+3)! \sum_{j=0}^{n+3} \left(\frac{2}{\gamma}\right)^j \frac{\tau^{3+n-j}}{(3+n-j)!} + \right. \\ \left. + \frac{5}{8} \gamma^4 (n+4)! \sum_{j=0}^{n+4} \left(\frac{2}{\gamma}\right)^j \frac{\tau^{4+n-j}}{(4+n-j)!} - \frac{1}{20} \gamma^5 (n+5)! \times \right. \\ \left. + \sum_{j=0}^{n+5} \left(\frac{2}{\gamma}\right)^j \frac{\tau^{5+n-j}}{(5+n-j)!} \right) \int \tau^n L_k^{(1)}(\tau, \gamma) d\tau.$$



Рис. 1.75. Вид неопределенного интеграла  $n$ -ого рода от ортогональных функций Сонина-Лагерра 2-ого порядка;  $n = 0, 5, \gamma = 8, \alpha = 1$



Рис. 1.76. Вид неопределенного интеграла от ортогональных функций Сонина-Лагерра 0-5 порядков;  $\gamma = 8, \alpha = 2$

$$[1.77] \quad \int \tau L_k^{(2)}(\tau, \gamma) d\tau = -\frac{2}{\gamma} \exp\left(-\frac{\gamma\tau}{2}\right) \sum_{s=0}^k \binom{k+2}{k-s} \times$$

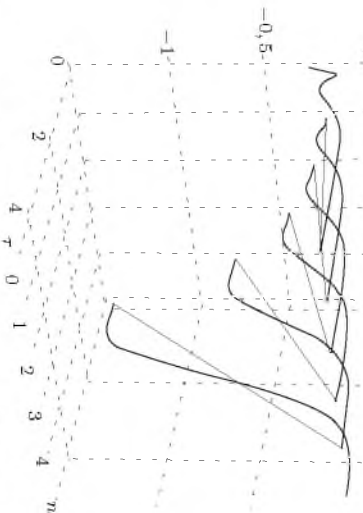
$$\times (-\gamma)^s (s+1) \sum_{j=0}^{s+1} \left(\frac{2}{\gamma}\right)^j \frac{\tau^{s+1-j}}{(s+1-j)!}.$$

Частные случаи для неопределенного интеграла 1-ого рода от

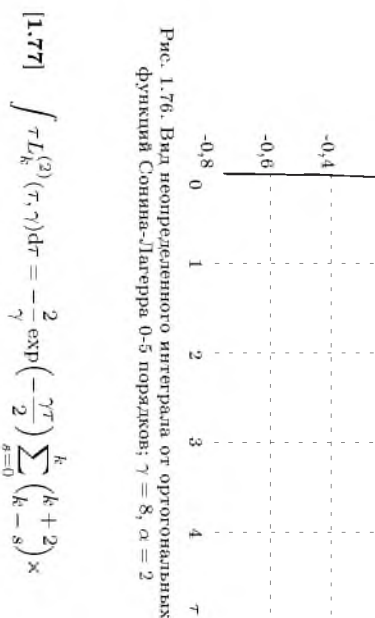
функций 0-5 порядков:

$$\int \tau L_0^{(2)}(\tau, \gamma) d\tau = -\frac{2}{\gamma^2} \exp\left(-\frac{\gamma\tau}{2}\right) (\gamma\tau + 2);$$

$$\int \tau L_1^{(2)}(\tau, \gamma) d\tau = \frac{2}{\gamma^2} \exp\left(-\frac{\gamma\tau}{2}\right) (\gamma^2 \tau^2 + \gamma\tau + 2);$$

$$\int \tau L_2^{(2)}(\tau, \gamma) d\tau = -\frac{1}{\gamma^2} \exp\left(-\frac{\gamma\tau}{2}\right) (\gamma^3 \tau^3 - 2\gamma^2 \tau^2 + 4\gamma\tau + 8);$$

$$\int \tau L_3^{(2)}(\tau, \gamma) d\tau = \frac{1}{3\gamma^2} \exp\left(-\frac{\gamma\tau}{2}\right) (\gamma^4 \tau^4 - 7\gamma^3 \tau^3 + 18\gamma^2 \tau^2 +$$

$$+ 12\gamma\tau + 24);$$

$$\int \tau L_4^{(2)}(\tau, \gamma) d\tau = -\frac{1}{12\gamma^2} \exp\left(-\frac{\gamma\tau}{2}\right) (\gamma^5 \tau^5 - 14\gamma^4 \tau^4 + 68 \times$$

$$\times \gamma^3 \tau^3 - 72\gamma^2 \tau^2 + 72\gamma\tau + 144);$$

### 1.3 Аналитические соотношения для неопределенных интегралов от ортогональных функций

$$-2\gamma(n+1)! \sum_{j=0}^{n+1} \left(\frac{2}{\gamma}\right)^j \frac{\tau^{1+n-j}}{(1+n-j)!};$$

$$\int \tau^n L_2^{(1)}(\tau, \gamma) d\tau = -\frac{2}{\gamma} \exp\left(-\frac{\gamma\tau}{2}\right) \left( n! \sum_{j=0}^n \left(\frac{2}{\gamma}\right)^j \frac{\tau^{n-j}}{(n-j)!} - \right.$$

$$\left. -3\gamma(n+1)! \sum_{j=0}^{n+1} \left(\frac{2}{\gamma}\right)^j \frac{\tau^{1+n-j}}{(1+n-j)!} + \frac{3}{2} \gamma^2(n+2)! \times \right.$$

$$\left. \times \sum_{j=0}^{n+2} \left(\frac{2}{\gamma}\right)^j \frac{\tau^{2+n-j}}{(2+n-j)!} \right);$$

$$\int \tau^n L_3^{(1)}(\tau, \gamma) d\tau = -\frac{2}{\gamma} \exp\left(-\frac{\gamma\tau}{2}\right) \left( n! \sum_{j=0}^n \left(\frac{2}{\gamma}\right)^j \frac{\tau^{n-j}}{(n-j)!} - \right.$$

$$\left. -4\gamma(n+1)! \sum_{j=0}^{n+1} \left(\frac{2}{\gamma}\right)^j \frac{\tau^{1+n-j}}{(1+n-j)!} + 3\gamma^2(n+2)! \times \right.$$

$$\left. \times \sum_{j=0}^{n+2} \left(\frac{2}{\gamma}\right)^j \frac{\tau^{2+n-j}}{(2+n-j)!} - \frac{2}{3} \gamma^3(n+3)! \sum_{j=0}^{n+3} \left(\frac{2}{\gamma}\right)^j \frac{\tau^{3+n-j}}{(3+n-j)!} \right);$$

$$\int \tau^n L_4^{(1)}(\tau, \gamma) d\tau = -\frac{2}{\gamma} \exp\left(-\frac{\gamma\tau}{2}\right) \left( n! \sum_{j=0}^n \left(\frac{2}{\gamma}\right)^j \frac{\tau^{n-j}}{(n-j)!} - \right.$$

$$\left. -5\gamma(n+1)! \sum_{j=0}^{n+1} \left(\frac{2}{\gamma}\right)^j \frac{\tau^{1+n-j}}{(1+n-j)!} + 5\gamma^2(n+2)! \times \right.$$

$$\left. \times \sum_{j=0}^{n+2} \left(\frac{2}{\gamma}\right)^j \frac{\tau^{2+n-j}}{(2+n-j)!} - \frac{5}{3} \gamma^3(n+3)! \sum_{j=0}^{n+3} \left(\frac{2}{\gamma}\right)^j \frac{\tau^{3+n-j}}{(3+n-j)!} + \right.$$

$$\left. + \frac{5}{24} \gamma^4(n+4)! \sum_{j=0}^{n+4} \left(\frac{2}{\gamma}\right)^j \frac{\tau^{4+n-j}}{(4+n-j)!} \right);$$

$$[1.76] \int L_k^{(2)}(\tau, \gamma) d\tau = -\frac{2}{\gamma} \exp\left(-\frac{\gamma\tau}{2}\right) \sum_{s=0}^k \binom{k+2}{k-s} \times$$

$$\times (-\gamma)^s \sum_{j=0}^s \binom{2}{\gamma}^j \frac{\tau^{s-j}}{(s-j)!};$$

Частные случаи для неопределенного интеграла от функций 0-5 порядков:

$$\int L_0^{(2)}(\tau, \gamma) d\tau = -\frac{2}{\gamma} \exp\left(-\frac{\gamma\tau}{2}\right);$$

$$\int L_1^{(2)}(\tau, \gamma) d\tau = \frac{2}{\gamma} \exp\left(-\frac{\gamma\tau}{2}\right) (\gamma\tau - 1);$$

$$\int L_2^{(2)}(\tau, \gamma) d\tau = -\frac{1}{\gamma} \exp\left(-\frac{\gamma\tau}{2}\right) (\gamma^2\tau^2 - 4\gamma\tau + 4);$$

$$\int L_3^{(2)}(\tau, \gamma) d\tau = \frac{1}{3\gamma} \exp\left(-\frac{\gamma\tau}{2}\right) (\gamma^3\tau^3 - 9\gamma^2\tau^2 + 24\gamma\tau - 12);$$

$$\int L_4^{(2)}(\tau, \gamma) d\tau = -\frac{1}{12\gamma} \exp\left(-\frac{\gamma\tau}{2}\right) (\gamma^4\tau^4 - 16\gamma^3\tau^3 + 84\gamma^2\tau^2 -$$

$$-144\gamma\tau + 72);$$

$$\int L_5^{(2)}(\tau, \gamma) d\tau = \frac{1}{60\gamma} \exp\left(-\frac{\gamma\tau}{2}\right) (\gamma^5\tau^5 - 25\gamma^4\tau^4 + 220\gamma^3\tau^3 -$$

$$-780\gamma^2\tau^2 + 1080\gamma\tau - 360);$$

$$\int L_k^{(2)}(\tau, \gamma) d\tau$$

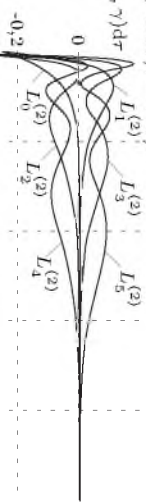



Рис. 1.77. Вид неопределенного интеграла 1-ого рода от ортогональных функций Сонина-Лагерра 0-5 порядков;  $\gamma = 8, \alpha = 2$

$$[1.78] \int \tau^2 L_k^{(2)}(\tau, \gamma) d\tau = -\frac{2}{\gamma} \exp\left(-\frac{\gamma\tau}{2}\right) \sum_{s=0}^k \binom{k+2}{k-s} \times (-\gamma)^s (s+1)(s+2) \sum_{j=0}^{s+2} \left(\frac{2}{\gamma}\right)^j \frac{\tau^{s+2-j}}{(s+2-j)!}.$$

Частные случаи для неопределенного интеграла 2-ого рода от функций 0-5 порядков:

$$\begin{aligned} \int \tau^2 L_0^{(2)}(\tau, \gamma) d\tau &= -\frac{2}{\gamma^3} \exp\left(-\frac{\gamma\tau}{2}\right) (\gamma^2 \tau^2 + 4\gamma\tau + 8); \\ \int \tau^2 L_1^{(2)}(\tau, \gamma) d\tau &= \frac{2}{\gamma^3} \exp\left(-\frac{\gamma\tau}{2}\right) (\gamma^3 \tau^3 + 3\gamma^2 \tau^2 + 12\gamma\tau + 24); \\ \int \tau^2 L_2^{(2)}(\tau, \gamma) d\tau &= -\frac{1}{\gamma^3} \exp\left(-\frac{\gamma\tau}{2}\right) (\gamma^4 \tau^4 + 12\gamma^2 \tau^2 + 48\gamma\tau + 96); \\ \int \tau^2 L_3^{(2)}(\tau, \gamma) d\tau &= \frac{1}{\gamma^3} \exp\left(-\frac{\gamma\tau}{2}\right) (\gamma^5 \tau^5 - 5\gamma^4 \tau^4 + 20\gamma^3 \tau^3 + 60\gamma^2 \tau^2 + 240\gamma\tau + 480); \\ \int \tau^2 L_4^{(2)}(\tau, \gamma) d\tau &= -\frac{1}{12\gamma^3} \exp\left(-\frac{\gamma\tau}{2}\right) (\gamma^6 \tau^6 - 12\gamma^5 \tau^5 + 60 \times \\ &\times \gamma^4 \tau^4 + 360\gamma^2 \tau^2 + 1440\gamma\tau + 2880); \\ \int \tau^2 L_5^{(2)}(\tau, \gamma) d\tau &= \frac{\gamma^3}{960} \exp\left(-\frac{\gamma\tau}{2}\right) (\gamma^7 \tau^7 - 21\gamma^6 \tau^6 + 168 \times \\ &\times \gamma^5 \tau^5 - 420\gamma^4 \tau^4 + 840\gamma^3 \tau^3 + 2520\gamma^2 \tau^2 + 10080\gamma\tau + 20160). \end{aligned}$$

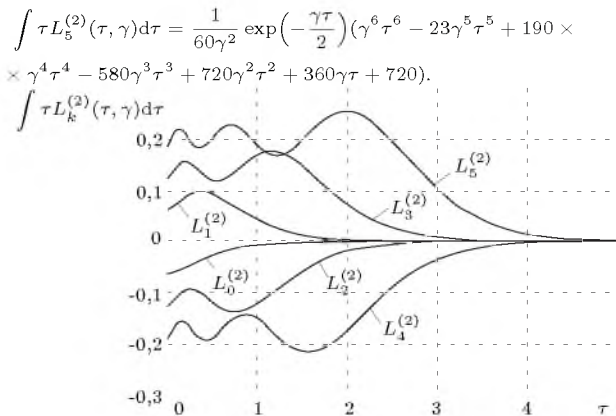

Рис. 1.78. Вид неопределенного интеграла 2-ого рода от ортогональных функций Сонина-Лагерра 0-5 порядков;  $\gamma = 8, \alpha = 2$

$$[1.79] \int \tau^3 L_k^{(2)}(\tau, \gamma) d\tau = -\frac{2}{\gamma} \exp\left(-\frac{\gamma\tau}{2}\right) \sum_{s=0}^k \binom{k+2}{k-s} \times (-\gamma)^s (s+1)(s+2)(s+3) \sum_{j=0}^{s+3} \left(\frac{2}{\gamma}\right)^j \frac{\tau^{s+3-j}}{(s+3-j)!}.$$

Частные случаи для неопределенного интеграла 3-ого рода от функций 0-5 порядков:

$$\begin{aligned} \int \tau^3 L_0^{(2)}(\tau, \gamma) d\tau &= -\frac{2}{\gamma^4} \exp\left(-\frac{\gamma\tau}{2}\right) (\gamma^3 \tau^3 + 6\gamma^2 \tau^2 + 24\gamma\tau + 48); \\ \int \tau^3 L_1^{(2)}(\tau, \gamma) d\tau &= \frac{2}{\gamma^4} \exp\left(-\frac{\gamma\tau}{2}\right) (\gamma^4 \tau^4 + 5\gamma^3 \tau^3 + 30\gamma^2 \tau^2 + 120\gamma\tau + 240); \\ \int \tau^3 L_2^{(2)}(\tau, \gamma) d\tau &= -\frac{1}{\gamma^4} \exp\left(-\frac{\gamma\tau}{2}\right) (\gamma^5 \tau^5 + 2\gamma^4 \tau^4 + 28\gamma^3 \tau^3 + 168\gamma^2 \tau^2 + 672\gamma\tau + 1344); \\ \int \tau^3 L_3^{(2)}(\tau, \gamma) d\tau &= \frac{1}{3\gamma^4} \exp\left(-\frac{\gamma\tau}{2}\right) (\gamma^6 \tau^6 - 3\gamma^5 \tau^5 + 30\gamma^4 \tau^4 + 180\gamma^3 \tau^3 + 1080\gamma^2 \tau^2 + 4320\gamma\tau + 8640); \\ \int \tau^3 L_4^{(2)}(\tau, \gamma) d\tau &= -\frac{1}{12\gamma^4} \exp\left(-\frac{\gamma\tau}{2}\right) (\gamma^7 \tau^7 - 10\gamma^6 \tau^6 + 60 \times \\ &\times \gamma^5 \tau^5 + 120\gamma^4 \tau^4 + 1320\gamma^3 \tau^3 + 7920\gamma^2 \tau^2 + 31680\gamma\tau + 63360); \\ \int \tau^3 L_5^{(2)}(\tau, \gamma) d\tau &= \frac{1}{60\gamma^4} \exp\left(-\frac{\gamma\tau}{2}\right) (\gamma^8 \tau^8 - 19\gamma^7 \tau^7 + 154 \times \\ &\times \gamma^6 \tau^6 - 252\gamma^5 \tau^5 + 1680\gamma^4 \tau^4 + 10920\gamma^3 \tau^3 + 65520\gamma^2 \tau^2 + 262080\gamma\tau + 524160). \end{aligned}$$

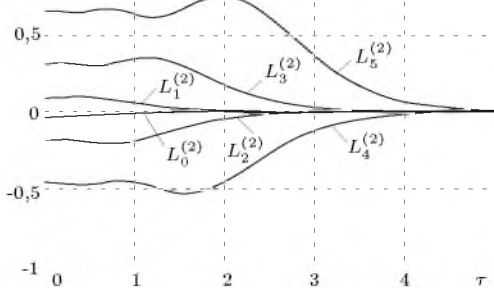

Рис. 1.79. Вид неопределенного интеграла 3-ого рода от ортогональных функций Сонина-Лагерра 0-5 порядков;  $\gamma = 8, \alpha = 2$

$$[1.80] \int \tau^n L_k^{(2)}(\tau, \gamma) d\tau = -\frac{2}{\gamma} \exp\left(-\frac{\gamma\tau}{2}\right) \sum_{s=0}^k \binom{k+2}{k-s} \times (-\gamma)^s \frac{(s+n)!}{s!} \sum_{j=0}^{s+n} \left(\frac{2}{\gamma}\right)^j \frac{\tau^{s+n-j}}{(s+n-j)!}.$$

Частные случаи для неопределенного интеграла n-ого рода от функций 0-5 порядков:

$$\begin{aligned} \int \tau^n L_0^{(2)}(\tau, \gamma) d\tau &= -\frac{2n!}{\gamma} \exp\left(-\frac{\gamma\tau}{2}\right) \sum_{j=0}^n \left(\frac{2}{\gamma}\right)^j \frac{\tau^{n-j}}{(n-j)!}; \\ \int \tau^n L_1^{(2)}(\tau, \gamma) d\tau &= -\frac{2}{\gamma} \exp\left(-\frac{\gamma\tau}{2}\right) \left( n! \sum_{j=0}^n \left(\frac{2}{\gamma}\right)^j \frac{\tau^{n-j}}{(n-j)!} - \right. \end{aligned}$$

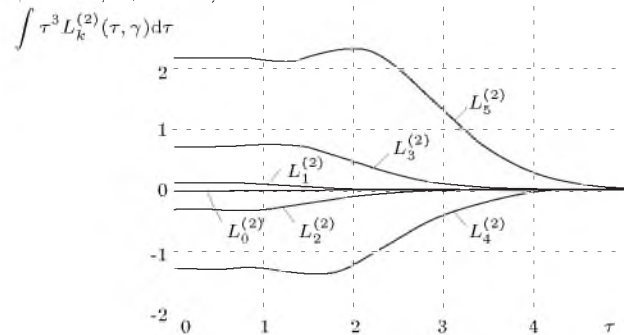
$$\begin{aligned}
\int \tau^n L_4^{(2)}(\tau, \gamma) d\tau &= -\frac{2}{\gamma} \exp\left(-\frac{\gamma\tau}{2}\right) \left( n! \sum_{j=0}^n \binom{2}{\gamma}^j \frac{\tau^{n-j}}{(n-j)!} - \right. \\
&- 6\gamma(n+1)! \sum_{j=0}^{n+1} \left(\frac{2}{\gamma}\right)^j \frac{\tau^{1+n-j}}{(1+n-j)!} + \frac{15}{2} \gamma^2(n+2)! \times \\
&\times \sum_{j=0}^{n+2} \left(\frac{2}{\gamma}\right)^j \frac{\tau^{2+n-j}}{(2+n-j)!} - \frac{10}{3} \gamma^3(n+3)! \sum_{j=0}^{n+3} \left(\frac{2}{\gamma}\right)^j \times \\
&\times \left. \frac{\tau^{3+n-j}}{(3+n-j)!} + \frac{5}{8} \gamma^4(n+4)! \sum_{j=0}^{n+4} \left(\frac{2}{\gamma}\right)^j \frac{\tau^{4+n-j}}{(4+n-j)!} \right); \\
\int \tau^n L_5^{(2)}(\tau, \gamma) d\tau &= -\frac{2}{\gamma} \exp\left(-\frac{\gamma\tau}{2}\right) \left( n! \sum_{j=0}^n \binom{2}{\gamma}^j \frac{\tau^{n-j}}{(n-j)!} - \right. \\
&- 7\gamma(n+1)! \sum_{j=0}^{1+n} \left(\frac{2}{\gamma}\right)^j \frac{\tau^{1+n-j}}{(1+n-j)!} + \frac{21}{2} \gamma^2(n+2)! \times \\
&\times \sum_{j=0}^{n+2} \left(\frac{2}{\gamma}\right)^j \frac{\tau^{2+n-j}}{(2+n-j)!} - \frac{35}{6} \gamma^3(n+3)! \sum_{j=0}^{n+3} \left(\frac{2}{\gamma}\right)^j \times \\
&\times \left. \frac{\tau^{3+n-j}}{(3+n-j)!} + \frac{35}{24} \gamma^4(n+4)! \sum_{j=0}^{n+4} \left(\frac{2}{\gamma}\right)^j \frac{\tau^{4+n-j}}{(4+n-j)!} - \right. \\
&- \left. \frac{7}{40} \gamma^5(n+5)! \sum_{j=0}^{n+5} \left(\frac{2}{\gamma}\right)^j \frac{\tau^{5+n-j}}{(5+n-j)!} \right).
\end{aligned}$$

$$\begin{aligned}
\mathbf{1.811} \quad \int L_k^{(\alpha)}(\tau, \gamma) d\tau &= -\frac{2}{\gamma} \exp\left(-\frac{\gamma\tau}{2}\right) \sum_{s=0}^k \binom{k+\alpha}{\gamma}^s \frac{\tau^{k-s}}{(k-s)!} \times \\
&\times (-\gamma)^s \sum_{j=0}^s \binom{2}{\gamma}^j \frac{\tau^{s-j}}{(s-j)!}.
\end{aligned}$$

Частные случаи для неопределенного интеграла от функций 0-5 порядков:

$$\begin{aligned}
\int L_0^{(\alpha)}(\tau, \gamma) d\tau &= -\frac{2}{\gamma} \exp\left(-\frac{\gamma\tau}{2}\right); \\
\int L_1^{(\alpha)}(\tau, \gamma) d\tau &= \frac{2}{\gamma} \exp\left(-\frac{\gamma\tau}{2}\right) (\gamma\tau - \alpha + 1); \\
\int L_2^{(\alpha)}(\tau, \gamma) d\tau &= -\frac{1}{\gamma} \exp\left(-\frac{\gamma\tau}{2}\right) (\gamma^2\tau^2 - 2\alpha\gamma\tau + \alpha^2 - \alpha + 2); \\
\int L_3^{(\alpha)}(\tau, \gamma) d\tau &= \frac{1}{3\gamma} \exp\left(-\frac{\gamma\tau}{2}\right) (\gamma^3\tau^3 - 3(\alpha+1)\gamma^2\tau^2 + 3 \times \\
&\times (\alpha^2 + \alpha + 2)\gamma\tau - \alpha^3 - 5\alpha + 6); \\
\int L_4^{(\alpha)}(\tau, \gamma) d\tau &= -\frac{1}{12\gamma} \exp\left(-\frac{\gamma\tau}{2}\right) (\gamma^4\tau^4 - 4(\alpha+2)\gamma^3\tau^3 + 6 \times \\
&\times (\alpha^2 + 3\alpha + 4)\gamma^2\tau^2 - 4(\alpha^3 + 3\alpha^2 + 8\alpha)\gamma\tau + \alpha^4 + 2\alpha^3 + 11\alpha^2 - \\
&- 14\alpha + 24); \\
\int L_5^{(\alpha)}(\tau, \gamma) d\tau &= \frac{1}{60\gamma} \exp\left(-\frac{\gamma\tau}{2}\right) (\gamma^5\tau^5 - 5(\alpha+3)\gamma^4\tau^4 + 10 \times \\
&\times (\alpha^2 + 5\alpha + 8)\gamma^3\tau^3 - 10(\alpha^3 + 6\alpha^2 + 17\alpha + 12)\gamma^2\tau^2 + 5(\alpha^4 + 6\alpha^3 + \\
&+ 23\alpha^2 + 18\alpha + 24)\gamma\tau - \alpha^5 - 5\alpha^4 - 25\alpha^3 + 5\alpha^2 - 94\alpha + 120).
\end{aligned}$$



### 1.3 Аналитические соотношения для неопределенных интегралов от ортогональных функций

$$- 3\gamma(n+1)! \sum_{j=0}^{n+1} \left(\frac{2}{\gamma}\right)^j \frac{\tau^{1+n-j}}{(1+n-j)!};$$

$$\int \tau^n L_2^{(2)}(\tau, \gamma) d\tau = -\frac{2}{\gamma} \exp\left(-\frac{\gamma\tau}{2}\right) \left( n! \sum_{j=0}^n \left(\frac{2}{\gamma}\right)^j \frac{\tau^{n-j}}{(n-j)!} -$$

$$- 4\gamma(n+1)! \sum_{j=0}^{n+1} \left(\frac{2}{\gamma}\right)^j \frac{\tau^{1+n-j}}{(1+n-j)!} + 3\gamma^2(n+2)! \times$$

$$\times \sum_{j=0}^{2+n} \left(\frac{2}{\gamma}\right)^j \frac{\tau^{2+n-j}}{(2+n-j)!};$$

$$\int \tau^n L_3^{(2)}(\tau, \gamma) d\tau = -\frac{2}{\gamma} \exp\left(-\frac{\gamma\tau}{2}\right) \left( n! \sum_{j=0}^n \left(\frac{2}{\gamma}\right)^j \frac{\tau^{n-j}}{(n-j)!} -$$

$$- 5\gamma(n+1)! \sum_{j=0}^{n+1} \left(\frac{2}{\gamma}\right)^j \frac{\tau^{1+n-j}}{(1+n-j)!} + 5\gamma^2(n+2)! \times$$

$$\times \sum_{j=0}^{n+2} \left(\frac{2}{\gamma}\right)^j \frac{\tau^{2+n-j}}{(2+n-j)!} - \frac{5}{3}\gamma^3(n+3)! \sum_{j=0}^{n+3} \left(\frac{2}{\gamma}\right)^j \frac{\tau^{3+n-j}}{(3+n-j)!};$$



Рис. 1.80. Вид неопределенного интеграла  $n$ -ого порядка от ортогональных функций Сонин-Лагерра 2-ого порядка;  $n = 0..5, \gamma = 8, \alpha = 2$



Рис. 1.81. Вид неопределенного интеграла от ортогональных функций Сонина-Лагерра 2-ого порядка: а)  $\gamma = 8, \alpha \in [0; 5]$ ; б)  $\gamma \in [5; 10], \alpha = 1$

[1.82] 
$$\int \tau L_k^{(\alpha)}(\tau, \gamma) d\tau = -\frac{2}{\gamma} \exp\left(-\frac{\gamma\tau}{2}\right) \sum_{s=0}^k \binom{k+\alpha}{k-s} \times$$

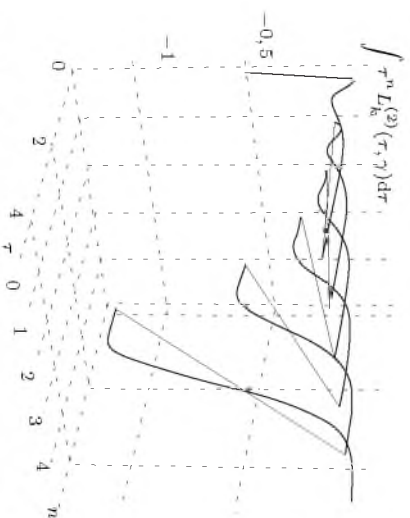
$$\times (-\gamma)^s (s+1) \sum_{j=0}^{s+1} \left(\frac{2}{\gamma}\right)^j \frac{\tau^{s+1-j}}{(s+1-j)!}.$$

Частные случаи для неопределенного интеграла 1-ого рода от функций 0-5 порядков:

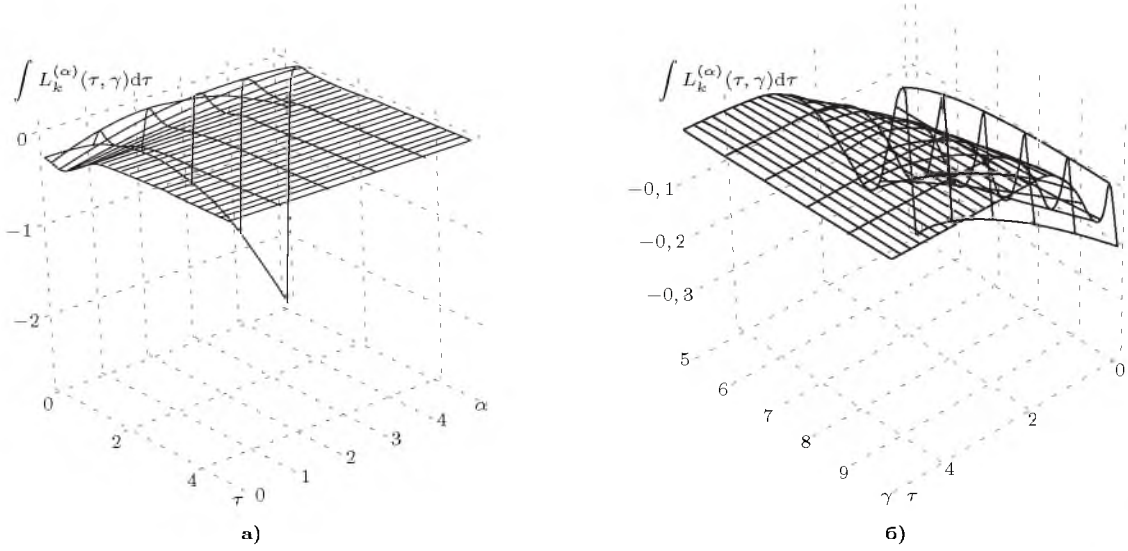
$$\int \tau L_0^{(\alpha)}(\tau, \gamma) d\tau = -\frac{2}{\gamma^2} \exp\left(-\frac{\gamma\tau}{2}\right) (\gamma\tau + 2);$$

$$\int \tau L_1^{(\alpha)}(\tau, \gamma) d\tau = \frac{2}{\gamma^2} \exp\left(-\frac{\gamma\tau}{2}\right) (\gamma^2\tau^2 - (\alpha - 3)\gamma\tau - 2\alpha + 6);$$

$$\int \tau L_2^{(\alpha)}(\tau, \gamma) d\tau = -\frac{1}{\gamma^2} \exp\left(-\frac{\gamma\tau}{2}\right) (\gamma^3\tau^3 - 2(\alpha - 1)\gamma^2\tau^2 +$$

$$+ (\alpha^2 - 5\alpha + 10)\gamma\tau + 2\alpha^2 - 10\alpha + 20);$$

$$\int \tau L_3^{(\alpha)}(\tau, \gamma) d\tau = \frac{1}{3\gamma^2} \exp\left(-\frac{\gamma\tau}{2}\right) (\gamma^4\tau^4 - (3\alpha + 1)\gamma^3\tau^3 +$$

$$+ 3(\alpha^2 - \alpha + 4)\gamma^2\tau^2 - (\alpha^3 - 6\alpha^2 + 23\alpha - 42)\gamma\tau - 2(\alpha^3 + 6\alpha^2 -$$

$$- 23\alpha + 42));$$

$$\int \tau L_4^{(\alpha)}(\tau, \gamma) d\tau = -\frac{1}{12\gamma^2} \exp\left(-\frac{\gamma\tau}{2}\right) (\gamma^5\tau^5 - 2(2\alpha + 3)\gamma^4\tau^4 +$$

$$+ 2(3\alpha^2 + 5\alpha + 12)\gamma^3\tau^3 - 4(\alpha^3 + 11\alpha - 12)\gamma^2\tau^2 + (\alpha^4 + 6\alpha^3 +$$

$$+ 35\alpha^2 - 126\alpha + 216)\gamma\tau + 2(\alpha^4 - 6\alpha^3 + 35\alpha^2 - 126\alpha + 216));$$

$$\int \tau L_5^{(\alpha)}(\tau, \gamma) d\tau = \frac{1}{60\gamma^2} \exp\left(-\frac{\gamma\tau}{2}\right) (\gamma^6\tau^6 - (5\alpha + 13)\gamma^5\tau^5 +$$

$$+ 10(\alpha^2 + 4\alpha + 7)\gamma^4\tau^4 - 10(\alpha^3 + 4\alpha^2 + 15\alpha + 4)\gamma^3\tau^3 + 5(\alpha^4 + 2\alpha^3 +$$

$$+ 23\alpha^2 - 26\alpha + 72)\gamma^2\tau^2 - (\alpha^5 - 5\alpha^4 + 45\alpha^3 - 235\alpha^2 + 794\alpha -$$

$$- 1320)\gamma\tau - 2(\alpha^5 - 5\alpha^4 + 45\alpha^3 - 235\alpha^2 + 794\alpha - 1320)).$$



Рис. 1.82. Вид неопределенного интеграла 1-ого рода от ортогональных функций Сонина-Лагерра 2-ого порядка: а)  $\gamma = 8, \alpha \in [0; 5]$ ; б)  $\gamma \in [5; 10], \alpha = 1$

$$[1.83] \quad \int \tau^2 L_k^{(\alpha)}(\tau, \gamma) d\tau = -\frac{2}{\gamma} \exp\left(-\frac{\gamma\tau}{2}\right) \sum_{s=0}^k \binom{k+\alpha}{k-s} \times \\ \times (-\gamma)^s (s+1)(s+2) \sum_{j=0}^{s+2} \left(\frac{2}{\gamma}\right)^j \frac{\tau^{s+2-j}}{(s+2-j)!}.$$

Частные случаи для неопределенного интеграла 2-ого рода от функций 0-5 порядков:

$$\int \tau^2 L_0^{(\alpha)}(\tau, \gamma) d\tau = -\frac{2}{\gamma^3} \exp\left(-\frac{\gamma\tau}{2}\right) (\gamma^2 \tau^2 + 4\gamma\tau + 8); \\ \int \tau^2 L_1^{(\alpha)}(\tau, \gamma) d\tau = \frac{2}{\gamma^3} \exp\left(-\frac{\gamma\tau}{2}\right) (\gamma^3 \tau^3 - (\alpha-5)\gamma^2 \tau^2 - 4 \times \\ \times (\alpha-5)\gamma\tau - 8(\alpha-5)); \\ \int \tau^2 L_2^{(\alpha)}(\tau, \gamma) d\tau = -\frac{1}{\gamma^3} \exp\left(-\frac{\gamma\tau}{2}\right) (\gamma^4 \tau^4 - 2(\alpha-2)\gamma^3 \tau^3 +$$

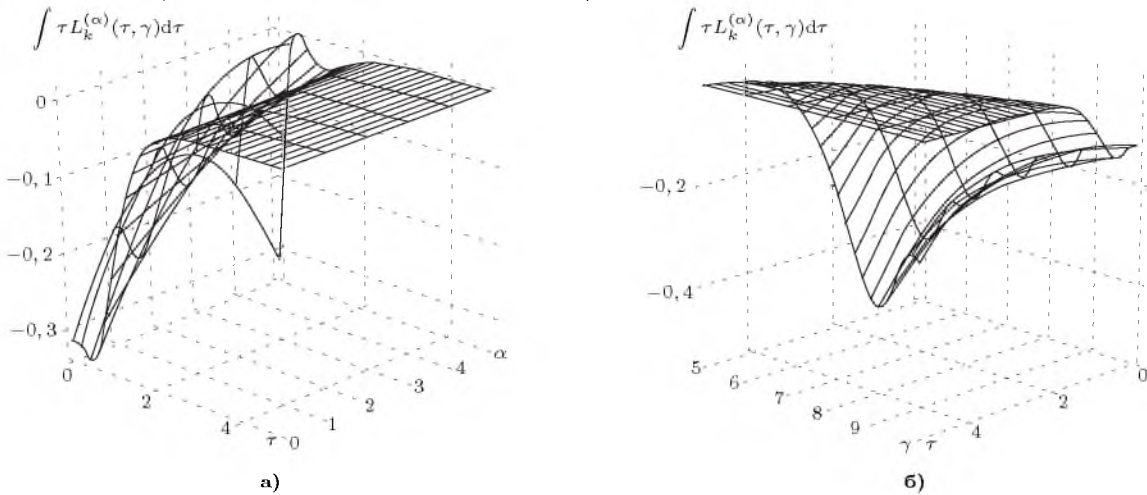
$$+ (\alpha^2 - 9\alpha + 26)\gamma^2 \tau^2 + 4(\alpha^2 - 9\alpha + 26)\gamma\tau + 8(\alpha^2 - 9\alpha + 26)); \\ \int \tau^2 L_3^{(\alpha)}(\tau, \gamma) d\tau = \frac{1}{3\gamma^3} \exp\left(-\frac{\gamma\tau}{2}\right) (\gamma^5 \tau^5 - (3\alpha-1)\gamma^4 \tau^4 + \\ + (3\alpha^2 - 9\alpha + 26)\gamma^3 \tau^3 - (\alpha^3 - 12\alpha^2 + 65\alpha - 150)\gamma^2 \tau^2 - 4 \times \\ \times (\alpha^3 - 12\alpha^2 + 65\alpha - 150)\gamma\tau - 8(\alpha^3 + 12\alpha^2 - 65\alpha + 150)); \\ \int \tau^2 L_4^{(\alpha)}(\tau, \gamma) d\tau = -\frac{1}{12\gamma^3} \exp\left(-\frac{\gamma\tau}{2}\right) (\gamma^6 \tau^6 - 4(\alpha+1)\gamma^5 \tau^5 + \\ + 2(3\alpha^2 + \alpha + 16)\gamma^4 \tau^4 - 4(\alpha^3 - 3\alpha^2 + 22\alpha - 40)\gamma^3 \tau^3 + \\ + (\alpha^4 - 14\alpha^3 + 107\alpha^2 - 478\alpha + 984)\gamma^2 \tau^2 + 4(\alpha^4 - 14\alpha^3 + 107 \times \\ \times \alpha^2 - 478\alpha + 984)\gamma\tau + 8(\alpha^4 - 14\alpha^3 + 107\alpha^2 - 478\alpha + 984)); \\ \int \tau^2 L_5^{(\alpha)}(\tau, \gamma) d\tau = \frac{1}{60\gamma^3} \exp\left(-\frac{\gamma\tau}{2}\right) (\gamma^7 \tau^7 - (5\alpha+11)\gamma^6 \tau^6 + \\ + 2(5\alpha^2 + 15\alpha + 34)\gamma^5 \tau^5 - 10(\alpha^3 + 2\alpha^2 + 17\alpha - 8)\gamma^4 \tau^4 + 5 \times \\ \times (\alpha^4 - 2\alpha^3 + 39\alpha^2 - 118\alpha + 248)\gamma^3 \tau^3 - (\alpha^5 - 15\alpha^4 + 145\alpha^3 - 945 \times \\ \times \alpha^2 + 3814\alpha - 7320)\gamma^2 \tau^2 - 4(\alpha^5 - 15\alpha^4 + 145\alpha^3 - 945\alpha^2 + 3814 \times \\ \times \alpha - 7320)\gamma\tau - 8(\alpha^5 - 15\alpha^4 + 145\alpha^3 - 945\alpha^2 + 3814\alpha - 7320)).$$



Рис. 1.83. Вид неопределенного интеграла 2-ого рода от ортогональных функций Сонина-Лагерра 2-ого порядка: а)  $\gamma = 8$ ,  $\alpha \in [0; 5]$ ; б)  $\gamma \in [5; 10]$ ,  $\alpha = 1$

$$[1.84] \quad \int \tau^3 L_k^{(\alpha)}(\tau, \gamma) d\tau = -\frac{2}{\gamma} \exp\left(-\frac{\gamma\tau}{2}\right) \sum_{s=0}^k \binom{k+\alpha}{k-s} \times \\ \times (-\gamma)^s (s+1)(s+2)(s+3) \sum_{j=0}^{s+3} \left(\frac{2}{\gamma}\right)^j \frac{\tau^{s+3-j}}{(s+3-j)!}.$$

Частные случаи для неопределенного интеграла 3-ого рода от функций 0-5 порядков:

$$\int \tau^3 L_0^{(\alpha)}(\tau, \gamma) d\tau = -\frac{2}{\gamma^4} \exp\left(-\frac{\gamma\tau}{2}\right) (\gamma^3 \tau^3 + 6\gamma^2 \tau^2 + 24\gamma\tau + \\ + 48); \\ \int \tau^3 L_1^{(\alpha)}(\tau, \gamma) d\tau = \frac{2}{\gamma^4} \exp\left(-\frac{\gamma\tau}{2}\right) (\gamma^4 \tau^4 - (\alpha-7)\gamma^3 \tau^3 - 6 \times \\ \times (\alpha-7)\gamma^2 \tau^2 - 24(\alpha-7)\gamma\tau - 48(\alpha-7)); \\ \int \tau^3 L_2^{(\alpha)}(\tau, \gamma) d\tau = -\frac{1}{\gamma^4} \exp\left(-\frac{\gamma\tau}{2}\right) (\gamma^5 \tau^5 - 2(\alpha-3)\gamma^4 \tau^4 + \\ + (\alpha^2 - 13\alpha + 50)\gamma^3 \tau^3 + 6(\alpha^2 - 13\alpha + 50)\gamma^2 \tau^2 + 24(\alpha^2 - 13\alpha + \\ + 50)\gamma\tau + 48(\alpha^2 - 13\alpha + 50));$$

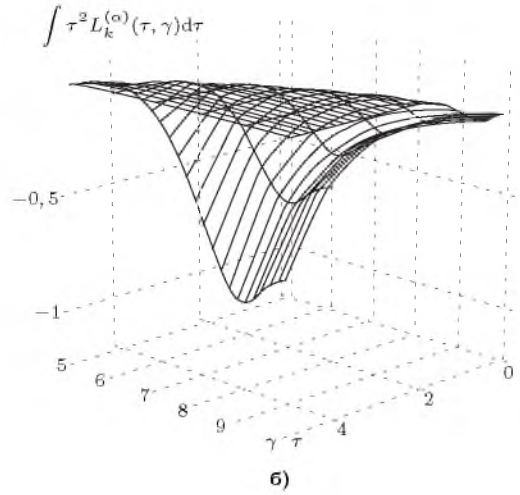
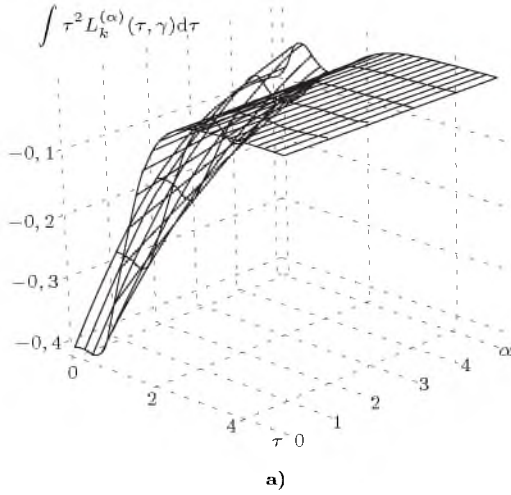
$$\int \tau^3 L_3^{(\alpha)}(\tau, \gamma) d\tau = \frac{1}{3\gamma^4} \exp\left(-\frac{\gamma\tau}{2}\right) (\gamma^6 \tau^6 - 3(\alpha-1)\gamma^5 \tau^5 + 3 \times \\ \times (\alpha^2 - 5\alpha + 16)\gamma^4 \tau^4 - (\alpha^3 - 18\alpha^2 + 131\alpha - 378)\gamma^3 \tau^3 - 6(\alpha^3 - \\ - 18\alpha^2 + 131\alpha - 378)\gamma^2 \tau^2 - 24(\alpha^3 - 18\alpha^2 + 131\alpha - 378)\gamma\tau - \\ - 48(\alpha^3 - 18\alpha^2 + 131\alpha - 378)); \\ \int \tau^3 L_4^{(\alpha)}(\tau, \gamma) d\tau = -\frac{1}{12\gamma^4} \exp\left(-\frac{\gamma\tau}{2}\right) (\gamma^7 \tau^7 - 2(2\alpha+1) \times \\ \times \gamma^6 \tau^6 + 6(\alpha^2 - \alpha + 8)\gamma^5 \tau^5 - 4(\alpha^3 - 6\alpha^2 + 41\alpha - 96)\gamma^4 \tau^4 + \\ + 4(\alpha^4 - 22\alpha^3 + 227\alpha^2 - 1262\alpha + 3096)\gamma^3 \tau^3 + 6(\alpha^4 - 22\alpha^3 + 227 \times \\ \times \alpha^2 - 1262\alpha + 3096)\gamma^2 \tau^2 + 24(\alpha^4 - 22\alpha^3 + 227\alpha^2 - 1262\alpha + \\ + 3096)\gamma\tau + 48(\alpha^4 - 22\alpha^3 + 227\alpha^2 - 1262\alpha + 3096)); \\ \int \tau^3 L_5^{(\alpha)}(\tau, \gamma) d\tau = \frac{1}{60\gamma^4} \exp\left(-\frac{\gamma\tau}{2}\right) (\gamma^8 \tau^8 - (5\alpha+9)\gamma^7 \tau^7 + \\ + 2(5\alpha^2 + 10\alpha + 37)\gamma^6 \tau^6 - 2(5\alpha^3 - 115\alpha + 144)\gamma^5 \tau^5 + 5(\alpha^4 - \\ - 6\alpha^3 + 71\alpha^2 - 306\alpha + 696)\gamma^4 \tau^4 - (\alpha^5 - 25\alpha^4 + 325\alpha^3 - 2615\alpha^2 + \\ + 12514\alpha - 27720)\gamma^3 \tau^3 - 6(\alpha^5 - 25\alpha^4 + 325\alpha^3 - 2615\alpha^2 + \\ + 12514\alpha - 27720)\gamma^2 \tau^2 - 24(\alpha^5 - 25\alpha^4 + 325\alpha^3 - 2615\alpha^2 + \\ + 12514\alpha - 27720)\gamma\tau - 48(\alpha^5 - 25\alpha^4 + 325\alpha^3 - 2615\alpha^2 + 12514 \times \\ \times \alpha - 27720)).$$



Рис. 1.84. Вид неопределенного интеграла 3-ого рода от ортогональных функций Сонина-Лагерра 2-ого порядка: а)  $\gamma = 8$ ,  $\alpha \in [0; 5]$ ; б)  $\gamma \in [5; 10]$ ,  $\alpha = 1$

$$[1.85] \quad \int \tau^n L_k^{(\alpha)}(\tau, \gamma) d\tau = -\frac{2}{\gamma} \exp\left(-\frac{\gamma\tau}{2}\right) \sum_{s=0}^k \binom{k+\alpha}{k-s} \times \\ \times (-\gamma)^s \frac{(s+n)!}{s!} \sum_{j=0}^{s+n} \left(\frac{2}{\gamma}\right)^j \frac{\tau^{s+n-j}}{(s+n-j)!}.$$

Частные случаи для неопределенного интеграла  $n$ -ого рода от функций 0-5 порядков:

$$\int \tau^n L_0^{(\alpha)}(\tau, \gamma) d\tau = -\frac{2n!}{\gamma} \exp\left(-\frac{\gamma\tau}{2}\right) \sum_{j=0}^n \left(\frac{2}{\gamma}\right)^j \frac{\tau^{n-j}}{(n-j)!};$$

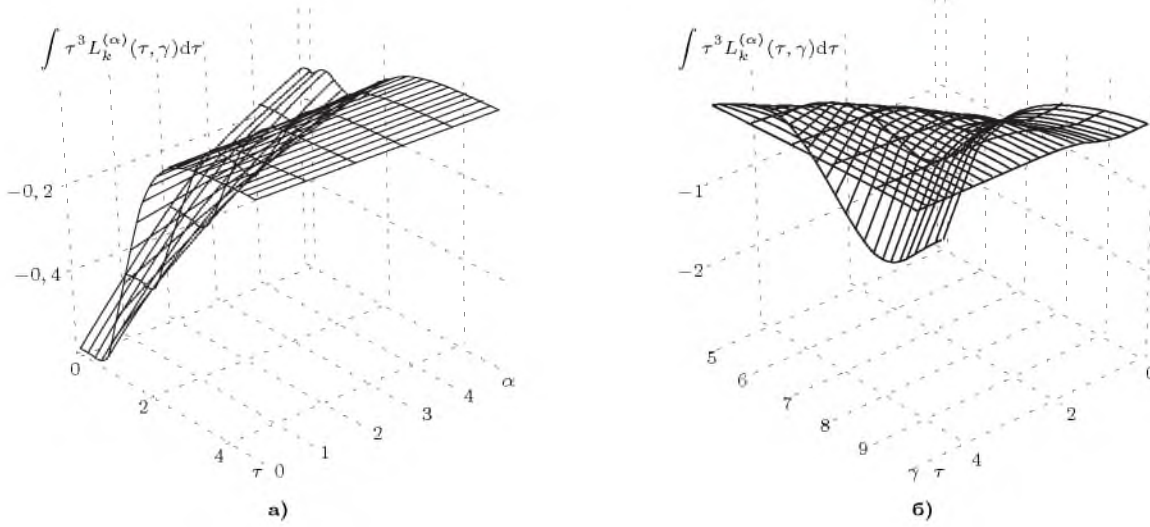
$$\int \tau^n L_1^{(\alpha)}(\tau, \gamma) d\tau = -\frac{2}{\gamma} \exp\left(-\frac{\gamma\tau}{2}\right) \left( n! \sum_{j=0}^n \left(\frac{2}{\gamma}\right)^j \frac{\tau^{n-j}}{(n-j)!} - \right. \\ \left. - (\alpha+1)\gamma(n+1)! \sum_{j=0}^{n+1} \left(\frac{2}{\gamma}\right)^j \frac{\tau^{1+n-j}}{(1+n-j)!} \right);$$

$$\int \tau^n L_2^{(\alpha)}(\tau, \gamma) d\tau = -\frac{2}{\gamma} \exp\left(-\frac{\gamma\tau}{2}\right) \left( n! \sum_{j=0}^n \left(\frac{2}{\gamma}\right)^j \frac{\tau^{n-j}}{(n-j)!} - \right. \\ \left. - (\alpha+2)\gamma(n+1)! \sum_{j=0}^{n+1} \left(\frac{2}{\gamma}\right)^j \frac{\tau^{1+n-j}}{(1+n-j)!} + \right. \\ \left. + (\alpha+1)(\alpha+2)\gamma^2(n+2)! \frac{1}{4} \sum_{j=0}^{n+2} \left(\frac{2}{\gamma}\right)^j \frac{\tau^{2+n-j}}{(2+n-j)!} \right);$$

$$\int \tau^n L_3^{(\alpha)}(\tau, \gamma) d\tau = -\frac{2}{\gamma} \exp\left(-\frac{\gamma\tau}{2}\right) \left( n! \sum_{j=0}^n \left(\frac{2}{\gamma}\right)^j \frac{\tau^{n-j}}{(n-j)!} - \right. \\ \left. - (\alpha+3)\gamma(n+1)! \sum_{j=0}^{n+1} \left(\frac{2}{\gamma}\right)^j \frac{\tau^{1+n-j}}{(1+n-j)!} + \right. \\ \left. + (\alpha+2)(\alpha+3)\gamma^2(n+2)! \frac{1}{4} \sum_{j=0}^{n+2} \left(\frac{2}{\gamma}\right)^j \frac{\tau^{2+n-j}}{(2+n-j)!} - \right.$$

$$\left. - (\alpha+1)(\alpha+2)(\alpha+3)\gamma^3(n+3)! \frac{1}{36} \sum_{j=0}^{n+3} \left(\frac{2}{\gamma}\right)^j \frac{\tau^{3+n-j}}{(3+n-j)!} \right);$$

$$\int \tau^n L_4^{(\alpha)}(\tau, \gamma) d\tau = -\frac{2}{\gamma} \exp\left(-\frac{\gamma\tau}{2}\right) \left( n! \sum_{j=0}^n \left(\frac{2}{\gamma}\right)^j \frac{\tau^{n-j}}{(n-j)!} - \right. \\ \left. - (\alpha+4)\gamma(n+1)! \sum_{j=0}^{n+1} \left(\frac{2}{\gamma}\right)^j \frac{\tau^{1+n-j}}{(1+n-j)!} + \right. \\ \left. + (\alpha+3)(\alpha+4)\gamma^2(n+2)! \frac{1}{4} \sum_{j=0}^{n+2} \left(\frac{2}{\gamma}\right)^j \frac{\tau^{2+n-j}}{(2+n-j)!} - \right. \\ \left. - (\alpha+2)(\alpha+3)(\alpha+4)\gamma^3(n+3)! \frac{1}{36} \sum_{j=0}^{n+3} \left(\frac{2}{\gamma}\right)^j \frac{\tau^{3+n-j}}{(3+n-j)!} + \right. \\ \left. + (\alpha+4)\gamma^4(n+4)! \frac{1}{24\alpha!} \sum_{j=0}^{n+4} \left(\frac{2}{\gamma}\right)^j \frac{\tau^{4+n-j}}{(4+n-j)!} \right);$$

$$\int \tau^n L_5^{(\alpha)}(\tau, \gamma) d\tau = -\frac{2}{\gamma} \exp\left(-\frac{\gamma\tau}{2}\right) \left( n! \sum_{j=0}^n \left(\frac{2}{\gamma}\right)^j \frac{\tau^{n-j}}{(n-j)!} - \right. \\ \left. - (\alpha+5)\gamma(n+1)! \sum_{j=0}^{n+1} \left(\frac{2}{\gamma}\right)^j \frac{\tau^{1+n-j}}{(1+n-j)!} + \right. \\ \left. + (\alpha+4)(\alpha+5)\gamma^2(n+2)! \frac{1}{4} \sum_{j=0}^{n+2} \left(\frac{2}{\gamma}\right)^j \frac{\tau^{2+n-j}}{(2+n-j)!} - \right. \\ \left. - (\alpha+3)(\alpha+4)(\alpha+5)\gamma^3(n+3)! \frac{1}{36} \sum_{j=0}^{n+3} \left(\frac{2}{\gamma}\right)^j \frac{\tau^{3+n-j}}{(3+n-j)!} + \right. \\ \left. + (\alpha+4)\gamma^4(n+4)! \frac{1}{576(\alpha+1)!} \sum_{j=0}^{n+4} \left(\frac{2}{\gamma}\right)^j \frac{\tau^{4+n-j}}{(4+n-j)!} - \right. \\ \left. - (\alpha+5)\gamma^5(n+5)! \frac{1}{14400\alpha!} \sum_{j=0}^{n+5} \left(\frac{2}{\gamma}\right)^j \frac{\tau^{5+n-j}}{(5+n-j)!} \right).$$



Рис. 1.85. Вид неопределенного интеграла n-ого рода от ортогональных функций Сонина-Лагерра 2-ого порядка: а)  $n = 0..5$ ,  $\gamma = 8$ ,  $\alpha \in [0; 5]$ ; б)  $n = 0..5$ ,  $\gamma \in [5; 10]$ ,  $\alpha = 1$

$$[1.86] \quad \int P_k^{(-1/2,0)}(\tau, \gamma) d\tau = - \sum_{s=0}^k \binom{k}{s} \binom{k+s-1/2}{s-1/2} \times \frac{2(-1)^s}{\gamma(4s+1)} \exp\left(-\frac{(4s+1)}{2}\gamma\tau\right).$$

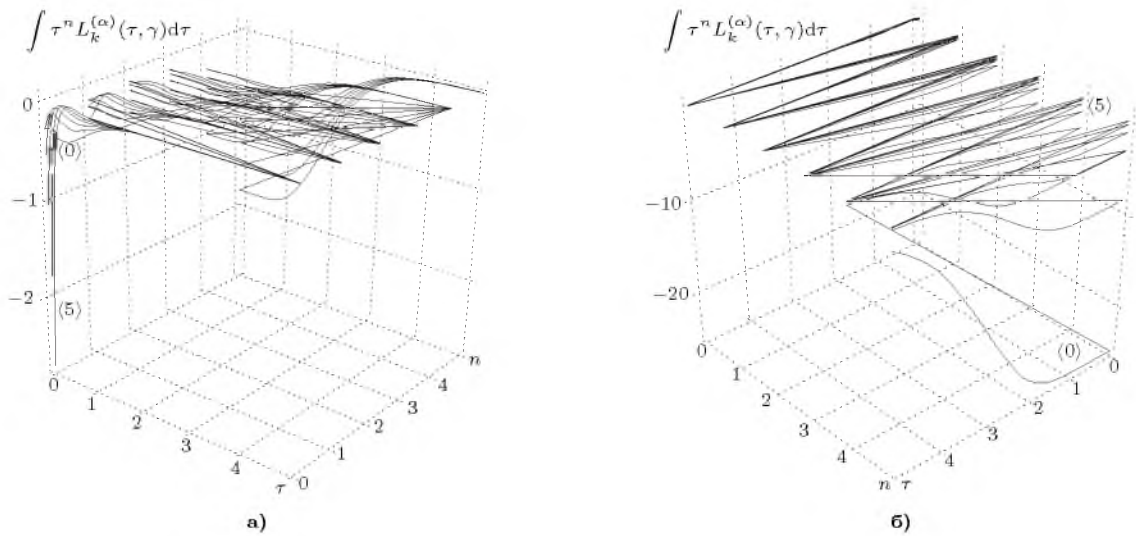

Рис. 1.86. Вид неопределенного интеграла от ортогональных функций Якоби 0-5 порядков;  $\gamma = 2$ ,  $c = 2$ ,  $\alpha = -1/2$ ,  $\beta = 0$

Частные случаи для неопределенного интеграла от функций 0-5 порядков:

$$\begin{aligned} \int P_0^{(-1/2,0)}(\tau, \gamma) d\tau &= -\frac{2}{\gamma} \exp\left(-\frac{\gamma\tau}{2}\right); \\ \int P_1^{(-1/2,0)}(\tau, \gamma) d\tau &= -\frac{1}{5\gamma} \exp\left(-\frac{\gamma\tau}{2}\right)(5 - 3\exp(-2\gamma\tau)); \\ \int P_2^{(-1/2,0)}(\tau, \gamma) d\tau &= -\frac{1}{36\gamma} \exp\left(-\frac{\gamma\tau}{2}\right)(27 - 54\exp(-2\gamma\tau) + \\ &+ 35\exp(-4\gamma\tau)); \\ \int P_3^{(-1/2,0)}(\tau, \gamma) d\tau &= -\frac{1}{104\gamma} \exp\left(-\frac{\gamma\tau}{2}\right)(65 - 273 \times \\ &\times \exp(-2\gamma\tau) + 455\exp(-4\gamma\tau) - 231\exp(-6\gamma\tau)); \\ \int P_4^{(-1/2,0)}(\tau, \gamma) d\tau &= -\frac{1}{1088\gamma} \exp\left(-\frac{\gamma\tau}{2}\right)(595 - 4284 \times \\ &\times \exp(-2\gamma\tau) + 13090\exp(-4\gamma\tau) - 15708\exp(-6\gamma\tau) + \\ &+ 6435\exp(-8\gamma\tau)); \\ \int P_5^{(-1/2,0)}(\tau, \gamma) d\tau &= -\frac{1}{2688\gamma} \exp\left(-\frac{\gamma\tau}{2}\right)(1323 - 14553 \times \\ &\times \exp(-2\gamma\tau) + 70070\exp(-4\gamma\tau) - 145530\exp(-6\gamma\tau) + \\ &+ 135135\exp(-8\gamma\tau) - 46189\exp(-10\gamma\tau)). \end{aligned}$$

$$[1.87] \quad \int \tau P_n^{(-1/2,0)}(\tau, \gamma) d\tau = - \sum_{s=0}^k \binom{k}{s} \binom{k+s-1/2}{s-1/2} \times \times (-1)^s \exp\left(-\frac{(4s+1)}{2}\gamma\tau\right) \left(\frac{2\tau}{\gamma(4s+1)} + \frac{4}{\gamma^2(4s+1)^2}\right).$$

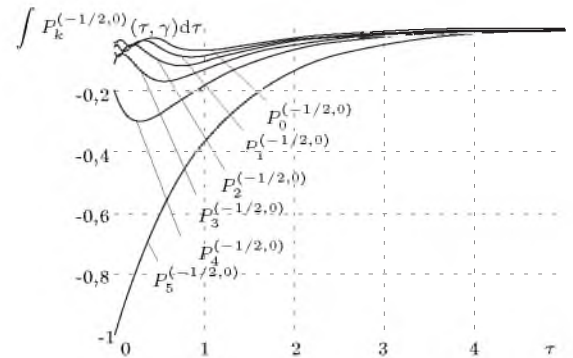
Частные случаи для неопределенного интеграла 1-ого рода от функций 0-5 порядков:

$$\begin{aligned} \int \tau P_0^{(-1/2,0)}(\tau, \gamma) d\tau &= -\frac{2}{\gamma^2} \exp\left(-\frac{\gamma\tau}{2}\right)(\gamma\tau + 2); \\ \int \tau P_1^{(-1/2,0)}(\tau, \gamma) d\tau &= -\frac{1}{25\gamma^2} \exp\left(-\frac{\gamma\tau}{2}\right)(50 - 6 \times \\ &\times \exp(-2\gamma\tau) + \gamma\tau(25 - 15\exp(-2\gamma\tau))); \\ \int \tau P_2^{(-1/2,0)}(\tau, \gamma) d\tau &= -\frac{1}{1620\gamma^2} \exp\left(-\frac{\gamma\tau}{2}\right)(2430 - 972 \times \\ &\times \exp(-2\gamma\tau) + 350\exp(-4\gamma\tau) + \gamma\tau(1215 - 2430\exp(-2\gamma\tau) + \\ &+ 1575\exp(-4\gamma\tau))); \\ \int \tau P_3^{(-1/2,0)}(\tau, \gamma) d\tau &= -\frac{1}{60840\gamma^2} \exp\left(-\frac{\gamma\tau}{2}\right)(76059 - \\ &- 63882\exp(-2\gamma\tau) + 59150\exp(-4\gamma\tau) - 20790\exp(-6\gamma\tau) + \end{aligned}$$

$$\begin{aligned}
 & + \gamma\tau(38025 - 159705 \exp(-2\gamma\tau) + 266175 \exp(-4\gamma\tau) - \\
 & - 135135 \exp(-6\gamma\tau)); \\
 & \int \tau P_4^{(-1/2,0)}(\tau, \gamma) d\tau = -\frac{1}{10820160\gamma^2} \exp\left(-\frac{\gamma\tau}{2}\right) (11834550 - \\
 & - 17041752 \exp(-2\gamma\tau) + 28928900 \exp(-4\gamma\tau) - 24033240 \times \\
 & \times \exp(-6\gamma\tau) + 7528950 \exp(-8\gamma\tau) + \gamma\tau(5917275 - \\
 & - 42604380 \exp(-2\gamma\tau) + 130180050 \exp(-4\gamma\tau) - 156216060 \times \\
 & \times \exp(-6\gamma\tau) + 63996075 \exp(-8\gamma\tau)); \\
 & \int \tau P_5^{(-1/2,0)}(\tau, \gamma) d\tau = -\frac{1}{187125120\gamma^2} \exp\left(-\frac{\gamma\tau}{2}\right) \times \\
 & \times (184201290 - 405242838 \exp(-2\gamma\tau) + 1083982900 \times \\
 & \times \exp(-4\gamma\tau) - 1558626300 \exp(-6\gamma\tau) + 1106755650 \times \\
 & \times \exp(-8\gamma\tau) - 306233070 \exp(-10\gamma\tau) + \gamma\tau(92100645 - \\
 & - 1013107095 \exp(-2\gamma\tau) + 4877923050 \exp(-4\gamma\tau) - \\
 & - 10131070950 \exp(-6\gamma\tau) + 9407423025 \exp(-8\gamma\tau) - \\
 & - 3215447235 \exp(-10\gamma\tau));
 \end{aligned}$$



Рис. 1.87. Вид неопределенного интеграла 1-ого рода от ортогональных функций Якоби 0-5 порядков;  $\gamma = 2, c = 2, \alpha = -1/2, \beta = 0$

[1.88] 
$$\begin{aligned}
 & \int \tau^2 P_k^{(-1/2,0)}(\tau, \gamma) d\tau = \\
 & = -\sum_{s=0}^k \binom{k}{s} \binom{k+s-1/2}{s-1/2} (-1)^s \exp\left(-\frac{(4s+1)\gamma\tau}{2}\right) \times \\
 & \times \left( \frac{2\tau^2}{\gamma(4s+1)} + \frac{8\tau}{\gamma^2(4s+1)^2} + \frac{16}{\gamma^3(4s+1)^3} \right).
 \end{aligned}$$

Частные случаи для неопределенного интеграла 2-ого рода от функций 0-5 порядков:

$$\begin{aligned}
 & \int \tau^2 P_0^{(-1/2,0)}(\tau, \gamma) d\tau = -\frac{2}{\gamma^3} \exp\left(-\frac{\gamma\tau}{2}\right) (\gamma^2\tau^2 + 4\gamma\tau + 8); \\
 & \int \tau^2 P_1^{(-1/2,0)}(\tau, \gamma) d\tau = -\frac{1}{125\gamma^3} \exp\left(-\frac{\gamma\tau}{2}\right) (1000 - 24 \times \\
 & \times \exp(-2\gamma\tau) + \gamma\tau(500 - 60 \exp(-2\gamma\tau)) + \gamma^2\tau^2(125 - 75 \times \\
 & \times \exp(-2\gamma\tau))); \\
 & \int \tau^2 P_2^{(-1/2,0)}(\tau, \gamma) d\tau = -\frac{1}{72900\gamma^3} \exp\left(-\frac{\gamma\tau}{2}\right) (437400 - \\
 & - 34992 \exp(-2\gamma\tau) + 7000 \exp(-4\gamma\tau) + \gamma\tau(218700 - 87480 \times \\
 & \times \exp(-2\gamma\tau) + 31500 \exp(-4\gamma\tau)) + \gamma^2\tau^2(54675 - 109350 \times \\
 & \times \exp(-2\gamma\tau) + 70875 \exp(-4\gamma\tau))); \\
 & \int \tau^2 P_3^{(-1/2,0)}(\tau, \gamma) d\tau = -\frac{1}{35591400\gamma^3} \exp\left(-\frac{\gamma\tau}{2}\right) \times \\
 & \times (177957000 - 29896776 \exp(-2\gamma\tau) + 15379000 \exp(-4\gamma\tau) - \\
 & - 3742200 \exp(-6\gamma\tau) + \gamma\tau(88978500 - 74741940 \exp(-2\gamma\tau) + \\
 & + 69205500 \exp(-4\gamma\tau) - 24324300 \exp(-6\gamma\tau)) + \gamma^2\tau^2 \times \\
 & \times (22244625 - 93427425 \exp(-2\gamma\tau) + 155712375 \exp(-4\gamma\tau) -
 \end{aligned}$$

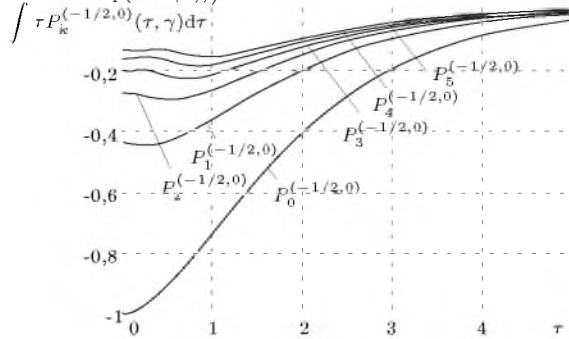
$$\begin{aligned}
 & - 79053975 \exp(-6\gamma\tau)); \\
 & \int \tau^2 P_4^{(-1/2,0)}(\tau, \gamma) d\tau = -\frac{1}{107606491200\gamma^3} \exp\left(-\frac{\gamma\tau}{2}\right) \times \\
 & \times (470778399000 - 135584178912 \exp(-2\gamma\tau) + 127865738000 \times \\
 & \times \exp(-4\gamma\tau) - 73541714400 \exp(-6\gamma\tau) + 17617743000 \times \\
 & \times \exp(-8\gamma\tau) + \gamma\tau(235389199500 - 338960447280 \exp(-2\gamma\tau) + \\
 & + 575395821000 \exp(-4\gamma\tau) - 478021143600 \exp(-6\gamma\tau) + \\
 & + 149750815500 \exp(-8\gamma\tau)) + \gamma^2\tau^2(58847299875 - \\
 & - 423700559100 \exp(-2\gamma\tau) + 1294640597250 \exp(-4\gamma\tau) - \\
 & - 1553568716700 \exp(-6\gamma\tau) + 636440965875 \exp(-8\gamma\tau)); \\
 & \int \tau^2 P_5^{(-1/2,0)}(\tau, \gamma) d\tau = -\frac{1}{13026715228800\gamma^3} \exp\left(-\frac{\gamma\tau}{2}\right) \times \\
 & \times (51292691213400 - 22568784133896 \exp(-2\gamma\tau) + \\
 & + 33538430926000 \exp(-4\gamma\tau) - 33385775346000 \exp(-6\gamma\tau) + \\
 & + 18128657547000 \exp(-8\gamma\tau) - 4060650508200 \exp(-10\gamma\tau) + \\
 & + \gamma\tau(25646345606700 - 56421960334740 \exp(-2\gamma\tau) + \\
 & + 150922939167000 \exp(-4\gamma\tau) - 217007539749000 \times \\
 & \times \exp(-6\gamma\tau) + 154093589149500 \exp(-8\gamma\tau) - \\
 & - 42636830336100 \exp(-10\gamma\tau)) + \gamma^2\tau^2(6411586401675 - \\
 & - 70527450418425 \exp(-2\gamma\tau) + 339576613125750 \exp(-4\gamma\tau) - \\
 & - 705274504184250 \exp(-6\gamma\tau) + 654897753885375 \times \\
 & \times \exp(-8\gamma\tau) - 223843359264525 \exp(-10\gamma\tau));
 \end{aligned}$$



Рис. 1.88. Вид неопределенного интеграла 2-ого рода от ортогональных функций Якоби 0-5 порядков;  $\gamma = 2, c = 2, \alpha = -1/2, \beta = 0$

[1.89] 
$$\begin{aligned}
 & \int \tau^3 P_k^{(-1/2,0)}(\tau, \gamma) d\tau = \\
 & = -\sum_{s=0}^k \binom{k}{s} \binom{k+s-1/2}{s-1/2} (-1)^s \exp\left(-\frac{(4s+1)\gamma\tau}{2}\right) \times \\
 & \times \left( \frac{2\tau^3}{\gamma(4s+1)} + \frac{12\tau^2}{\gamma^2(4s+1)^2} + \right. \\
 & \left. + \frac{48\tau}{\gamma^3(4s+1)^3} + \frac{96}{\gamma^4(4s+1)^4} \right).
 \end{aligned}$$

Частные случаи для неопределенного интеграла 3-ого рода от функций 0-5 порядков:

$$\begin{aligned}
 & \int \tau^3 P_0^{(-1/2,0)}(\tau, \gamma) d\tau = -\frac{2}{\gamma^4} \exp\left(-\frac{\gamma\tau}{2}\right) (\gamma^3\tau^3 + 6\gamma^2\tau^2 + \\
 & + 24\gamma\tau + 48); \\
 & \int \tau^3 P_1^{(-1/2,0)}(\tau, \gamma) d\tau = -\frac{1}{625\gamma^4} \exp\left(-\frac{\gamma\tau}{2}\right) (30000 - \\
 & - 144 \exp(-2\gamma\tau) + \gamma\tau(15000 - 360 \exp(-2\gamma\tau)) + \gamma^2\tau^2(3750 - \\
 & - 450 \exp(-2\gamma\tau)) + \gamma^3\tau^3(625 - 375 \exp(-2\gamma\tau))); \\
 & \int \tau^3 P_2^{(-1/2,0)}(\tau, \gamma) d\tau = -\frac{1}{1093500\gamma^4} \exp\left(-\frac{\gamma\tau}{2}\right) (39366000 - \\
 & - 629856 \exp(-2\gamma\tau) + 70000 \exp(-4\gamma\tau) + \gamma\tau(19683000 -
 \end{aligned}$$

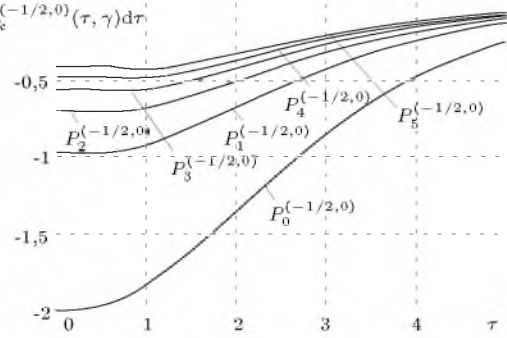
$$\begin{aligned}
 & -1574640 \exp(-2\gamma\tau) + 315000 \exp(-4\gamma\tau) + \gamma^2 \tau^2 (4920750 - \\
 & -1968300 \exp(-2\gamma\tau) + 708750 \exp(-4\gamma\tau) + \gamma^3 \tau^3 (820125 - \\
 & -1340250 \exp(-2\gamma\tau) + 1063125 \exp(-4\gamma\tau))); \\
 & \int \tau^3 P_3^{(-1/2,0)}(\tau, \gamma) d\tau = -\frac{1}{6940323000\gamma^4} \exp\left(-\frac{\gamma\tau}{2}\right) \times \\
 & \times (208209690000 - 6995845584 \exp(-2\gamma\tau) + 1999270000 \times \\
 & \times \exp(-4\gamma\tau) - 336798000 \exp(-6\gamma\tau) + \gamma\tau(104104845000 - \\
 & -17489613960 \exp(-2\gamma\tau) + 8996715000 \exp(-4\gamma\tau) - \\
 & -2189187000 \exp(-6\gamma\tau)) + \gamma^2 \tau^2 (26026211250 - 21862017450 \times \\
 & \times \exp(-2\gamma\tau) + 20242608750 \exp(-4\gamma\tau) - 7114857750 \times \\
 & \times \exp(-6\gamma\tau) + \gamma^3 \tau^3 (4337701875 - 18218347875 \exp(-2\gamma\tau) + \\
 & + 30363913125 \exp(-4\gamma\tau) - 15415525125 \exp(-6\gamma\tau))); \\
 & \int \tau^3 P_4^{(-1/2,0)}(\tau, \gamma) d\tau = -\frac{1}{356715518328000\gamma^4} \exp\left(-\frac{\gamma\tau}{2}\right) \times \\
 & \times (9363782356110000 - 539353863711936 \exp(-2\gamma\tau) + \\
 & + 282583280980000 \exp(-4\gamma\tau) - 112518823032000 \exp(-6\gamma\tau) + \\
 & + 20612759310000 \exp(-8\gamma\tau) + \gamma\tau(4681891178055000 - \\
 & -1348384659279840 \exp(-2\gamma\tau) + 1271624764410000 \times \\
 & \times \exp(-4\gamma\tau) - 731372349708000 \exp(-6\gamma\tau) + 175208454135000 \times \\
 & \times \exp(-8\gamma\tau)) + \gamma^2 \tau^2 (1170472794513750 - 1685480824099800 \times \\
 & \times \exp(-2\gamma\tau) + 2861155719922500 \exp(-4\gamma\tau) - \\
 & -2376960136551000 \exp(-6\gamma\tau) + 744635930073750 \times \\
 & \times \exp(-8\gamma\tau)) + \gamma^3 \tau^3 (195078799085625 - 1404567353416500 \times \\
 & \times \exp(-2\gamma\tau) + 4291733579883750 \exp(-4\gamma\tau) - \\
 & -5150080295860500 \exp(-6\gamma\tau) + 2109801801875625 \times \\
 & \times \exp(-8\gamma\tau)); \\
 & \int \tau^3 P_5^{(-1/2,0)}(\tau, \gamma) d\tau = -\frac{1}{302284926884304000\gamma^4} \times \\
 & \times \exp\left(-\frac{\gamma\tau}{2}\right) (7141481397641682000 - 628450362992468016 \times \\
 & \times \exp(-2\gamma\tau) + 518839526425220000 \exp(-4\gamma\tau) - \\
 & -357561653955660000 \exp(-6\gamma\tau) + 148473705309930000 \times \\
 & \times \exp(-8\gamma\tau) - 26922112869366000 \exp(-10\gamma\tau) + \\
 & + \gamma\tau(3570740698820841000 - 1571125907481170040 \exp(-2\gamma\tau) + \\
 & + 233477868913490000 \exp(-4\gamma\tau) - 2324150750711790000 \times \\
 & \times \exp(-6\gamma\tau) + 1262026495134405000 \exp(-8\gamma\tau) - \\
 & -282682185128343000 \exp(-10\gamma\tau)) + \gamma^2 \tau^2 \times \\
 & \times (892685174705210250 - 1963907384351462550 \exp(-2\gamma\tau) + \\
 & + 5253250205055352500 \exp(-4\gamma\tau) - 7553489939813317500 \times \\
 & \times \exp(-6\gamma\tau) + 5363612604321221250 \exp(-8\gamma\tau) - \\
 & -1484081471923800750 \exp(-10\gamma\tau)) + \gamma^3 \tau^3 \times \\
 & \times (148780862450868375 - 1636589486959552125 \exp(-2\gamma\tau) + \\
 & + 7879875307583028750 \exp(-4\gamma\tau) - 16365894869595521250 \times \\
 & \times \exp(-6\gamma\tau) + 15196902378910126875 \exp(-8\gamma\tau) - \\
 & -5194285151733302625 \exp(-10\gamma\tau)).
 \end{aligned}$$



Рис. 1.89. Вид неопределенного интеграла 3-го рода от ортогональных функций Якоби 0-5 порядков;  $\gamma = 2$ ,  $c = 2$ ,  $\alpha = -1/2$ ,  $\beta = 0$

$$\begin{aligned}
 [1.90] \quad & \int \tau^n P_k^{(-1/2,0)}(\tau, \gamma) d\tau = \\
 & = -\sum_{s=0}^k \binom{k}{s} \binom{k+s-1/2}{s-1/2} (-1)^s \exp\left(-\frac{(4s+1)\gamma\tau}{2}\right) \times \\
 & \times \sum_{j=0}^n \frac{n! \tau^{n-j}}{(n-j)! \left(\frac{\gamma(4s+1)}{2}\right)^{j+1}}.
 \end{aligned}$$

Частные случаи для неопределенного интеграла n-ого рода от функций 0-5 порядков:

$$\int \tau^n P_0^{(-1/2,0)}(\tau, \gamma) d\tau = -\frac{2n!}{\gamma} \exp\left(-\frac{\gamma\tau}{2}\right) \sum_{j=0}^n \left(\frac{2}{\gamma}\right)^j \frac{\tau^{n-j}}{(n-j)!};$$

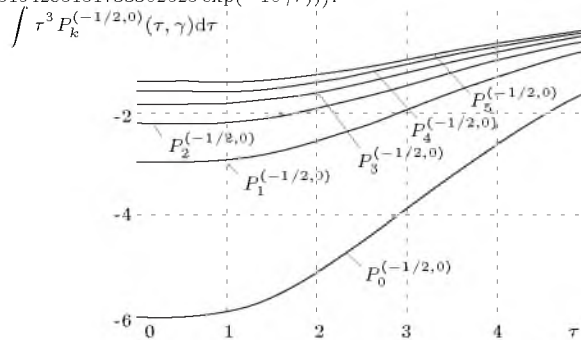
$$\int \tau^n P_1^{(-1/2,0)}(\tau, \gamma) d\tau = -\exp\left(-\frac{\gamma\tau}{2}\right) \times$$

$$\times \left( \frac{n!}{2} \sum_{j=0}^n \frac{\tau^{n-j}}{(n-j)! \left(\frac{\gamma}{2}\right)^{j+1}} - \right.$$

$$\left. - \frac{3n!}{2} \exp(-2\gamma\tau) \sum_{j=0}^n \frac{\tau^{n-j}}{(n-j)! \left(\frac{5\gamma}{2}\right)^{j+1}} \right);$$

$$\int \tau^n P_2^{(-1/2,0)}(\tau, \gamma) d\tau = -\exp\left(-\frac{\gamma\tau}{2}\right) \times$$

$$\times \left( \frac{3n!}{8} \sum_{j=0}^n \frac{\tau^{n-j}}{(n-j)! \left(\frac{\gamma}{2}\right)^{j+1}} - \right.$$

$$\left. - \frac{15n!}{4} \exp(-2\gamma\tau) \sum_{j=0}^n \frac{\tau^{n-j}}{(n-j)! \left(\frac{5\gamma}{2}\right)^{j+1}} + \right.$$

$$\left. + \frac{35n!}{8} \exp(-4\gamma\tau) \sum_{j=0}^n \frac{\tau^{n-j}}{(n-j)! \left(\frac{9\gamma}{2}\right)^{j+1}} \right);$$

$$\int \tau^n P_3^{(-1/2,0)}(\tau, \gamma) d\tau = -\exp\left(-\frac{\gamma\tau}{2}\right) \times$$

$$\times \left( \frac{5n!}{16} \sum_{j=0}^n \frac{\tau^{n-j}}{(n-j)! \left(\frac{\gamma}{2}\right)^{j+1}} - \right.$$

$$\left. - \frac{105n!}{16} \exp(-2\gamma\tau) \sum_{j=0}^n \frac{\tau^{n-j}}{(n-j)! \left(\frac{5\gamma}{2}\right)^{j+1}} + \right.$$

$$\left. + \frac{315n!}{16} \exp(-4\gamma\tau) \sum_{j=0}^n \frac{\tau^{n-j}}{(n-j)! \left(\frac{9\gamma}{2}\right)^{j+1}} - \right.$$

$$\left. - \frac{231n!}{16} \exp(-6\gamma\tau) \sum_{j=0}^n \frac{\tau^{n-j}}{(n-j)! \left(\frac{13\gamma}{2}\right)^{j+1}} \right);$$

$$\int \tau^n P_4^{(-1/2,0)}(\tau, \gamma) d\tau = -\exp\left(-\frac{\gamma\tau}{2}\right) \times$$

$$\times \left( \frac{35n!}{128} \sum_{j=0}^n \frac{\tau^{n-j}}{(n-j)! \left(\frac{\gamma}{2}\right)^{j+1}} - \right.$$



Рис. 1.90. Вид неопределенного интеграла n-ого рода от ортогональных функций Якоби 2-ого порядка;  $n = 0..5$ ,  $\gamma = 2$ ,  $c = 2$ ,  $\alpha = -1/2$ ,  $\beta = 0$

$$[1.91] \quad \int Leg_k(\tau, \gamma) d\tau = - \sum_{s=0}^k \binom{k}{s} \binom{k+s}{s} \times \frac{(-1)^s}{\gamma(2s+1)} \exp(-(2s+1)\gamma\tau).$$

Частные случаи для неопределенного интеграла от функций 0-5 порядков:

$$\begin{aligned} \int Leg_0(\tau, \gamma) d\tau &= -\frac{1}{\gamma} \exp(-\gamma\tau); \\ \int Leg_1(\tau, \gamma) d\tau &= -\frac{1}{3\gamma} \exp(-\gamma\tau)(3 - 2 \exp(-2\gamma\tau)); \\ \int Leg_2(\tau, \gamma) d\tau &= -\frac{1}{5\gamma} \exp(-\gamma\tau)(5 - 10 \exp(-2\gamma\tau) + 6 \times \\ &\times \exp(-4\gamma\tau)); \\ \int Leg_3(\tau, \gamma) d\tau &= -\frac{1}{7\gamma} \exp(-\gamma\tau)(7 - 28 \exp(-2\gamma\tau) + 42 \times \\ &\times \exp(-4\gamma\tau) - 20 \exp(-6\gamma\tau)); \\ \int Leg_4(\tau, \gamma) d\tau &= -\frac{1}{9\gamma} \exp(-\gamma\tau)(9 - 60 \exp(-2\gamma\tau) + 162 \times \\ &\times \exp(-4\gamma\tau) - 180 \exp(-6\gamma\tau) + 70 \exp(-8\gamma\tau)); \\ \int Leg_5(\tau, \gamma) d\tau &= -\frac{1}{11\gamma} \exp(-\gamma\tau)(11 - 110 \exp(-2\gamma\tau) + 462 \times \\ &\times \exp(-4\gamma\tau) - 880 \exp(-6\gamma\tau) + 770 \exp(-8\gamma\tau) - 252 \times \\ &\times \exp(-10\gamma\tau)). \end{aligned}$$

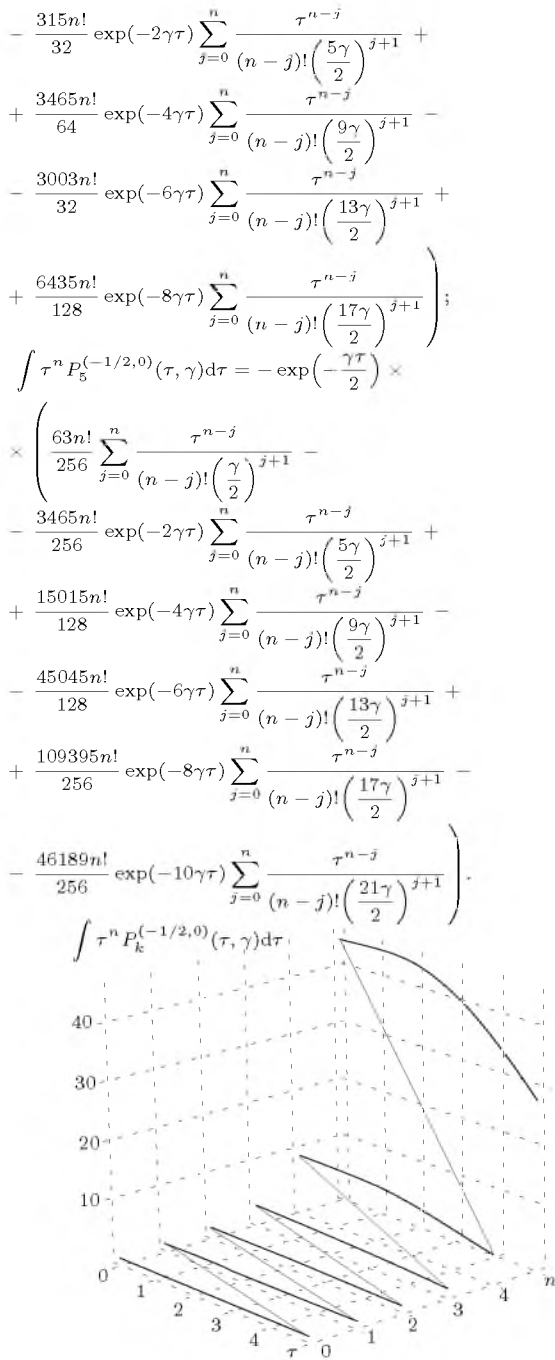

Рис. 1.91. Вид неопределенного интеграла от ортогональных функций Лежандра 0-5 порядков;  $\gamma = 2$ ,  $c = 2$

$$[1.92] \quad \int \tau Leg_k(\tau, \gamma) d\tau = - \sum_{s=0}^k \binom{k}{s} \binom{k+s}{s} (-1)^s \times \exp(-(2s+1)\gamma\tau) \left( \frac{\tau}{\gamma(2s+1)} + \frac{1}{\gamma^2(2s+1)^2} \right).$$

Частные случаи для неопределенного интеграла 1-ого рода от функций 0-5 порядков:

$$\begin{aligned} \int \tau Leg_0(\tau, \gamma) d\tau &= -\frac{1}{\gamma^2} \exp(-\gamma\tau)(\gamma\tau + 1); \\ \int \tau Leg_1(\tau, \gamma) d\tau &= -\frac{1}{9\gamma^2} \exp(-\gamma\tau)(9 - 2 \exp(-2\gamma\tau) + \gamma\tau(9 - \\ &- 6 \exp(-2\gamma\tau))); \\ \int \tau Leg_2(\tau, \gamma) d\tau &= -\frac{1}{75\gamma^2} \exp(-\gamma\tau)(75 - 50 \exp(-2\gamma\tau) + \\ &+ 18 \exp(-4\gamma\tau) + \gamma\tau(75 - 150 \exp(-2\gamma\tau) + 90 \exp(-4\gamma\tau))); \\ \int \tau Leg_3(\tau, \gamma) d\tau &= -\frac{1}{735\gamma^2} \exp(-\gamma\tau)(735 - 980 \exp(-2\gamma\tau) + \\ &+ 882 \exp(-4\gamma\tau) - 300 \exp(-6\gamma\tau) + \gamma\tau(735 - 2940 \exp(-2\gamma\tau) + \\ &+ 4410 \exp(-4\gamma\tau) - 2100 \exp(-6\gamma\tau))); \end{aligned}$$

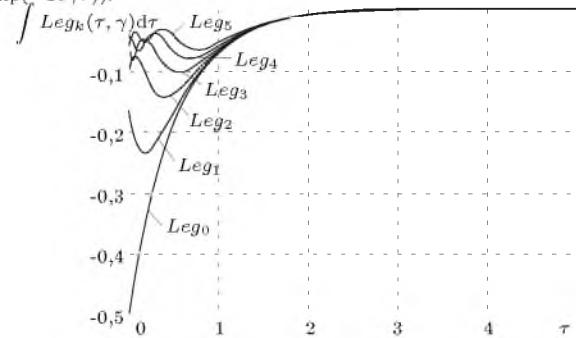



Рис. 1.92. Вид неопределенного интеграла 1-ого рода от ортогональных функций Лежандра 0-5 порядков;  $\gamma = 2, c = 2$

$$[1.93] \quad \int \tau^2 Leg_k(\tau, \gamma) d\tau = -\sum_{s=0}^k \binom{k}{s} \binom{k+s}{s} (-1)^s \times \exp(-(2s+1)\gamma\tau) \left( \frac{\tau^2}{\gamma(2s+1)} + \frac{2\tau}{\gamma^2(2s+1)^2} + \frac{2}{\gamma^3(2s+1)^3} \right).$$

Частные случаи для неопределенного интеграла 2-ого рода от функций 0-5 порядков:

$$\int \tau^2 Leg_0(\tau, \gamma) d\tau = -\frac{1}{\gamma^3} \exp(-\gamma\tau) (\gamma^2 \tau^2 + 2\gamma\tau + 2);$$

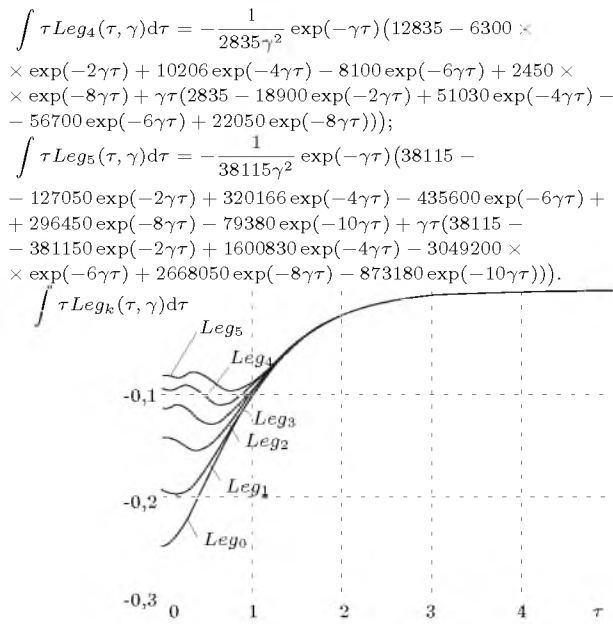
$$\int \tau^2 Leg_1(\tau, \gamma) d\tau = -\frac{1}{27\gamma^3} \exp(-\gamma\tau) (54 - 4 \exp(-2\gamma\tau) + \gamma\tau(54 - 12 \exp(-2\gamma\tau) + \gamma^2 \tau^2 (27 - 18 \exp(-2\gamma\tau)));$$

$$\int \tau^2 Leg_2(\tau, \gamma) d\tau = -\frac{1}{1125\gamma^3} \exp(-\gamma\tau) (2250 - 500 \times \exp(-2\gamma\tau) + 108 \exp(-4\gamma\tau) + \gamma\tau(2250 - 1500 \exp(-2\gamma\tau) + 540 \exp(-4\gamma\tau)) + \gamma^2 \tau^2 (1125 - 2250 \exp(-2\gamma\tau) + 1350 \times \exp(-4\gamma\tau)));$$

$$\int \tau^2 Leg_3(\tau, \gamma) d\tau = -\frac{1}{77175\gamma^3} \exp(-\gamma\tau) (154350 - 68600 \exp(-2\gamma\tau) + 37044 \exp(-4\gamma\tau) - 9000 \exp(-6\gamma\tau) + \gamma\tau(154350 - 205800 \exp(-2\gamma\tau) + 185220 \exp(-4\gamma\tau) - 63000 \exp(-6\gamma\tau)) + \gamma^2 \tau^2 (77175 - 308700 \exp(-2\gamma\tau) + 463050 \exp(-4\gamma\tau) - 220500 \exp(-6\gamma\tau)));$$

$$\int \tau^2 Leg_4(\tau, \gamma) d\tau = -\frac{1}{893025\gamma^3} \exp(-\gamma\tau) (1786050 - 1323000 \exp(-2\gamma\tau) + 1285956 \exp(-4\gamma\tau) - 729000 \times \exp(-6\gamma\tau) + 171500 \exp(-8\gamma\tau) + \gamma\tau(1786050 - 3969000 \times \exp(-2\gamma\tau) + 6429780 \exp(-4\gamma\tau) - 5103000 \exp(-6\gamma\tau) + 1543500 \exp(-8\gamma\tau)) + \gamma^2 \tau^2 (893025 - 5953500 \exp(-2\gamma\tau) +$$



Рис. 1.93. Вид неопределенного интеграла 2-ого рода от ортогональных функций Лежандра 0-5 порядков;  $\gamma = 2, c = 2$

$$[1.94] \quad \int \tau^3 Leg_k(\tau, \gamma) d\tau = -\sum_{s=0}^k \binom{k}{s} \binom{k+s}{s} (-1)^s \times \exp(-(2s+1)\gamma\tau) \left( \frac{\tau^3}{\gamma(2s+1)} + \frac{3\tau^2}{\gamma^2(2s+1)^2} + \frac{6\tau}{\gamma^3(2s+1)^3} + \frac{6}{\gamma^4(2s+1)^4} \right).$$

Частные случаи для неопределенного интеграла 3-ого рода от функций 0-5 порядков:

$$\int \tau^3 Leg_0(\tau, \gamma) d\tau = -\frac{1}{\gamma^4} \exp(-\gamma\tau) (\gamma^3 \tau^3 + 3\gamma^2 \tau^2 + 6\gamma\tau + 6);$$

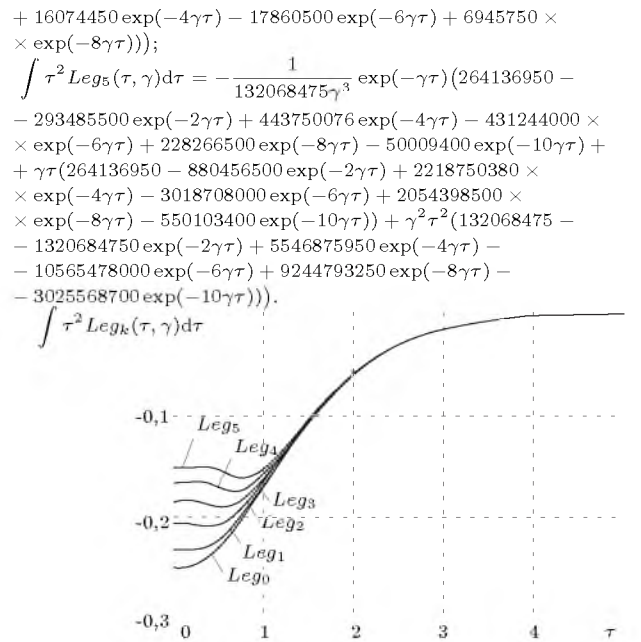
$$\int \tau^3 Leg_1(\tau, \gamma) d\tau = -\frac{1}{27\gamma^4} \exp(-\gamma\tau) (162 - 4 \exp(-2\gamma\tau) + \gamma\tau(162 - 12 \exp(-2\gamma\tau) + \gamma^2 \tau^2 (81 - 18 \exp(-2\gamma\tau)) + \gamma^3 \tau^3 \times (27 - 18 \exp(-2\gamma\tau)));$$

$$\int \tau^3 Leg_2(\tau, \gamma) d\tau = -\frac{1}{5625\gamma^4} \exp(-\gamma\tau) (33750 - 2500 \times \exp(-2\gamma\tau) + 324 \exp(-4\gamma\tau) + \gamma\tau(33750 - 7500 \exp(-2\gamma\tau) + 1620 \exp(-4\gamma\tau)) + \gamma^2 \tau^2 (16875 - 11250 \exp(-2\gamma\tau) + 4050 \times \exp(-4\gamma\tau)) + \gamma^3 \tau^3 (5625 - 11250 \exp(-2\gamma\tau) + 6750 \times \exp(-4\gamma\tau)));$$

$$\int \tau^3 Leg_3(\tau, \gamma) d\tau = -\frac{1}{2701125\gamma^4} \exp(-\gamma\tau) (16206750 - 2401000 \exp(-2\gamma\tau) + 777924 \exp(-4\gamma\tau) - 135000 \exp(-6\gamma\tau) + \gamma\tau(16206750 - 7203000 \exp(-2\gamma\tau) + 3889620 \exp(-4\gamma\tau) - 945000 \exp(-6\gamma\tau)) + \gamma^2 \tau^2 (8103375 - 10804500 \exp(-2\gamma\tau) + 9724050 \exp(-4\gamma\tau) - 3307500 \exp(-6\gamma\tau)) + \gamma^3 \tau^3 (2701125 - 10804500 \exp(-2\gamma\tau) + 16206750 \exp(-4\gamma\tau) - 7717500 \times \exp(-6\gamma\tau)));$$

$$\int \tau^3 Leg_4(\tau, \gamma) d\tau = -\frac{1}{93767625\gamma^4} \exp(-\gamma\tau) (562605750 -$$

$$\begin{aligned}
 & -138915000 \exp(-2\gamma\tau) + 81015228 \exp(-4\gamma\tau) - 32805000 \times \\
 & \times \exp(-6\gamma\tau) + 6002500 \exp(-8\gamma\tau) + \gamma\tau(562605750 - \\
 & - 416745000 \exp(-2\gamma\tau) + 405076140 \exp(-4\gamma\tau) - 229635000 \times \\
 & \times \exp(-6\gamma\tau) + 54022500 \exp(-8\gamma\tau)) + \gamma^2\tau^2(281302875 - \\
 & - 625117500 \exp(-2\gamma\tau) + 1012690350 \exp(-4\gamma\tau) - 803722500 \times \\
 & \times \exp(-6\gamma\tau) + 243101250 \exp(-8\gamma\tau)) + \gamma^3\tau^3(93767625 - \\
 & - 625117500 \exp(-2\gamma\tau) + 1687817250 \exp(-4\gamma\tau) - \\
 & - 1875352500 \exp(-6\gamma\tau) + 729303750 \exp(-8\gamma\tau)); \\
 & \int \tau^3 Leg_5(\tau, \gamma) d\tau = -\frac{1}{152539088625\gamma^4} \exp(-\gamma\tau) \times \\
 & \times (915234531750 - 338975752500 \exp(-2\gamma\tau) + \\
 & + 307518802668 \exp(-4\gamma\tau) - 213465780000 \exp(-6\gamma\tau) + \\
 & + 87882602500 \exp(-8\gamma\tau) - 15752961000 \exp(-10\gamma\tau) + \\
 & + \gamma\tau(915234531750 - 1016927257500 \exp(-2\gamma\tau) + \\
 & + 1537594013340 \exp(-4\gamma\tau) - 1494260460000 \exp(-6\gamma\tau) + \\
 & + 790943422500 \exp(-8\gamma\tau) - 173282571000 \exp(-10\gamma\tau)) + \\
 & + \gamma^2\tau^2(457617265875 - 1525390886250 \exp(-2\gamma\tau) + \\
 & + 3843985033350 \exp(-4\gamma\tau) - 5229911610000 \exp(-6\gamma\tau) + \\
 & + 3559245401250 \exp(-8\gamma\tau) - 953054140500 \exp(-10\gamma\tau)) + \\
 & + \gamma^3\tau^3(152539088625 - 1525390886250 \exp(-2\gamma\tau) + \\
 & + 6406641722250 \exp(-4\gamma\tau) - 12203127090000 \exp(-6\gamma\tau) + \\
 & + 10677736203750 \exp(-8\gamma\tau) - 3494531848500 \exp(-10\gamma\tau)); \\
 & \int \tau^3 Leg_k(\tau, \gamma) d\tau
 \end{aligned}$$



Рис. 1.94. Вид неопределенного интеграла 3-ого рода от ортогональных функций Лежандра 0-5 порядков;  $\gamma = 2, c = 2$

$$\begin{aligned}
 [1.95] \quad \int \tau^n Leg_k(\tau, \gamma) d\tau &= -\sum_{s=0}^k \binom{k}{s} \binom{k+s}{s} (-1)^s \times \\
 &\times \exp(-(2s+1)\gamma\tau) \sum_{j=0}^n \frac{n! \tau^{n-j}}{(n-j)! (\gamma(2s+1))^{j+1}}.
 \end{aligned}$$

Частные случаи для неопределенного интеграла n-ого рода от функций 0-5 порядков:

$$\begin{aligned}
 \int \tau^n Leg_0(\tau, \gamma) d\tau &= -\frac{2n!}{\gamma} \exp(-\gamma\tau) \sum_{j=0}^n \left(\frac{2}{\gamma}\right)^j \frac{\tau^{n-j}}{(n-j)!}; \\
 \int \tau^n Leg_1(\tau, \gamma) d\tau &= -\exp(-\gamma\tau) \times \\
 &\times \left( n! \sum_{j=0}^n \frac{\tau^{n-j}}{(n-j)! (\gamma)^{j+1}} - \right. \\
 &\left. - n! \exp(-2\gamma\tau) \sum_{j=0}^n \frac{\tau^{n-j}}{(n-j)! (3\gamma)^{j+1}} \right); \\
 \int \tau^n Leg_2(\tau, \gamma) d\tau &= -\exp(-\gamma\tau) \times
 \end{aligned}$$

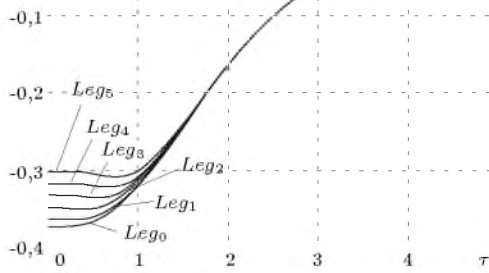
$$\begin{aligned}
 & \times \left( n! \sum_{j=0}^n \frac{\tau^{n-j}}{(n-j)! (\gamma)^{j+1}} - \right. \\
 & \left. - 6n! \exp(-2\gamma\tau) \sum_{j=0}^n \frac{\tau^{n-j}}{(n-j)! (3\gamma)^{j+1}} + \right. \\
 & \left. + 6n! \exp(-4\gamma\tau) \sum_{j=0}^n \frac{\tau^{n-j}}{(n-j)! (5\gamma)^{j+1}} \right); \\
 \int \tau^n Leg_3(\tau, \gamma) d\tau &= -\exp(-\gamma\tau) \times \\
 & \times \left( n! \sum_{j=0}^n \frac{\tau^{n-j}}{(n-j)! (\gamma)^{j+1}} - \right. \\
 & \left. - 12n! \exp(-2\gamma\tau) \sum_{j=0}^n \frac{\tau^{n-j}}{(n-j)! (3\gamma)^{j+1}} + \right. \\
 & \left. + 30n! \exp(-4\gamma\tau) \sum_{j=0}^n \frac{\tau^{n-j}}{(n-j)! (5\gamma)^{j+1}} - \right. \\
 & \left. - 20n! \exp(-6\gamma\tau) \sum_{j=0}^n \frac{\tau^{n-j}}{(n-j)! (7\gamma)^{j+1}} \right); \\
 \int \tau^n Leg_4(\tau, \gamma) d\tau &= -\exp(-\gamma\tau) \times \\
 & \times \left( n! \sum_{j=0}^n \frac{\tau^{n-j}}{(n-j)! (\gamma)^{j+1}} - \right. \\
 & \left. - 20n! \exp(-2\gamma\tau) \sum_{j=0}^n \frac{\tau^{n-j}}{(n-j)! (3\gamma)^{j+1}} + \right. \\
 & \left. + 90n! \exp(-4\gamma\tau) \sum_{j=0}^n \frac{\tau^{n-j}}{(n-j)! (5\gamma)^{j+1}} - \right. \\
 & \left. - 140n! \exp(-6\gamma\tau) \sum_{j=0}^n \frac{\tau^{n-j}}{(n-j)! (7\gamma)^{j+1}} + \right. \\
 & \left. + 70n! \exp(-8\gamma\tau) \sum_{j=0}^n \frac{\tau^{n-j}}{(n-j)! (9\gamma)^{j+1}} \right); \\
 \int \tau^n Leg_5(\tau, \gamma) d\tau &= -\exp(-\gamma\tau) \times \\
 & \times \left( n! \sum_{j=0}^n \frac{\tau^{n-j}}{(n-j)! (\gamma)^{j+1}} - \right. \\
 & \left. - 30n! \exp(-2\gamma\tau) \sum_{j=0}^n \frac{\tau^{n-j}}{(n-j)! (3\gamma)^{j+1}} + \right. \\
 & \left. + 210n! \exp(-4\gamma\tau) \sum_{j=0}^n \frac{\tau^{n-j}}{(n-j)! (5\gamma)^{j+1}} - \right. \\
 & \left. - 560n! \exp(-6\gamma\tau) \sum_{j=0}^n \frac{\tau^{n-j}}{(n-j)! (7\gamma)^{j+1}} + \right. \\
 & \left. + 630n! \exp(-8\gamma\tau) \sum_{j=0}^n \frac{\tau^{n-j}}{(n-j)! (9\gamma)^{j+1}} - \right. \\
 & \left. - 252n! \exp(-10\gamma\tau) \sum_{j=0}^n \frac{\tau^{n-j}}{(n-j)! (11\gamma)^{j+1}} \right).
 \end{aligned}$$



Рис. 1.95. Вид неопределенного интеграла n-ого рода от ортогональных функций Лежандра 2-ого порядка;  $n = 0..5$ ,  $\gamma = 2$ ,  $c = 2$

$$[1.96] \quad \int P_k^{(1/2,0)}(\tau, \gamma) d\tau = - \sum_{s=0}^k \binom{k}{s} \binom{k+s+1/2}{s+1/2} \times \frac{2(-1)^s}{\gamma(4s+3)} \exp\left(-\frac{(4s+3)}{2}\gamma\tau\right).$$

Частные случаи для неопределенного интеграла от функций 0-5 порядков:

$$\begin{aligned} \int P_0^{(1/2,0)}(\tau, \gamma) d\tau &= -\frac{2}{3\gamma} \exp\left(-\frac{3\gamma\tau}{2}\right); \\ \int P_1^{(1/2,0)}(\tau, \gamma) d\tau &= -\frac{1}{7\gamma} \exp\left(-\frac{3\gamma\tau}{2}\right)(7 - 5 \exp(-2\gamma\tau)); \\ \int P_2^{(1/2,0)}(\tau, \gamma) d\tau &= -\frac{1}{44\gamma} \exp\left(-\frac{3\gamma\tau}{2}\right)(55 - 110 \times \\ &\times \exp(-2\gamma\tau) + \\ &+ 63 \exp(-4\gamma\tau)); \\ \int P_3^{(1/2,0)}(\tau, \gamma) d\tau &= -\frac{1}{120\gamma} \exp\left(-\frac{3\gamma\tau}{2}\right)(175 - 675 \times \\ &\times \exp(-2\gamma\tau) + 945 \exp(-4\gamma\tau) - 429 \exp(-6\gamma\tau)); \\ \int P_4^{(1/2,0)}(\tau, \gamma) d\tau &= -\frac{1}{1216\gamma} \exp\left(-\frac{3\gamma\tau}{2}\right)(1995 - 12540 \times \\ &\times \exp(-2\gamma\tau) + 31122 \exp(-4\gamma\tau) - 32604 \exp(-6\gamma\tau) + 12155 \times \\ &\times \exp(-8\gamma\tau)); \\ \int P_5^{(1/2,0)}(\tau, \gamma) d\tau &= -\frac{1}{2944\gamma} \exp\left(-\frac{3\gamma\tau}{2}\right)(5313 - 49335 \times \\ &\times \exp(-2\gamma\tau) + 188370 \exp(-4\gamma\tau) - 335478 \exp(-6\gamma\tau) + \\ &+ 279565 \exp(-8\gamma\tau) - 88179 \exp(-10\gamma\tau)). \end{aligned}$$

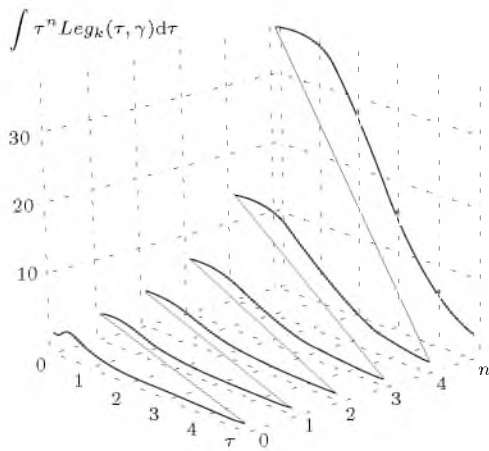

Рис. 1.96. Вид неопределенного интеграла от ортогональных функций Якоби 0-5 порядков;  $\gamma = 2$ ,  $c = 2$ ,  $\alpha = 1/2$ ,  $\beta = 0$

$$[1.97] \quad \int \tau P_k^{(1/2,0)}(\tau, \gamma) d\tau = - \sum_{s=0}^k \binom{k}{s} \binom{k+s+1/2}{s+1/2} \times (-1)^s \exp\left(-\frac{(4s+3)}{2}\gamma\tau\right) \left(\frac{2\tau}{\gamma(4s+3)} + \frac{4}{\gamma^2(4s+3)^2}\right).$$

Частные случаи для неопределенного интеграла 1-ого рода от функций 0-5 порядков:

$$\begin{aligned} \int \tau P_0^{(1/2,0)}(\tau, \gamma) d\tau &= -\frac{2}{9\gamma^2} \exp\left(-\frac{3\gamma\tau}{2}\right)(3\gamma\tau + 2); \\ \int \tau P_1^{(1/2,0)}(\tau, \gamma) d\tau &= -\frac{1}{147\gamma^2} \exp\left(-\frac{3\gamma\tau}{2}\right)(98 - 30 \times \\ &\times \exp(-2\gamma\tau) + \gamma\tau(147 - 105 \exp(-2\gamma\tau))); \\ \int \tau P_2^{(1/2,0)}(\tau, \gamma) d\tau &= -\frac{1}{10164\gamma^2} \exp\left(-\frac{3\gamma\tau}{2}\right)(8470 - 7260 \times \\ &\times \exp(-2\gamma\tau) + 2646 \exp(-4\gamma\tau) + \gamma\tau(12705 - 25410 \exp(-2\gamma\tau) + \\ &+ 14553 \exp(-4\gamma\tau))); \\ \int \tau P_3^{(1/2,0)}(\tau, \gamma) d\tau &= -\frac{1}{138600\gamma^2} \exp\left(-\frac{3\gamma\tau}{2}\right)(134750 - \\ &- 222750 \exp(-2\gamma\tau) + 198450 \exp(-4\gamma\tau) - 66066 \exp(-6\gamma\tau) + \\ &+ \gamma\tau(202125 - 779625 \exp(-2\gamma\tau) + 1091475 \exp(-4\gamma\tau) - \\ &- 495495 \exp(-6\gamma\tau))); \\ \int \tau P_4^{(1/2,0)}(\tau, \gamma) d\tau &= -\frac{1}{8895040\gamma^2} \exp\left(-\frac{3\gamma\tau}{2}\right)(9728950 - \\ &- 26208600 \exp(-2\gamma\tau) + 41392260 \exp(-4\gamma\tau) - 31799768 \times \\ &\times \exp(-6\gamma\tau) + 9359350 \exp(-8\gamma\tau) + \gamma\tau(14593425 - 91730100 \times \\ &\times \exp(-2\gamma\tau) + 227657430 \exp(-4\gamma\tau) - 238498260 \exp(-6\gamma\tau) + \\ &+ 88913825 \exp(-8\gamma\tau))); \\ \int \tau P_5^{(1/2,0)}(\tau, \gamma) d\tau &= -\frac{1}{495313280\gamma^2} \times \\ &\times \exp\left(-\frac{3\gamma\tau}{2}\right)(595923790 - 2371533450 \exp(-2\gamma\tau) + \\ &+ 5762238300 \exp(-4\gamma\tau) - 7525666148 \exp(-6\gamma\tau) + \\ &+ 4951096150 \exp(-8\gamma\tau) - 1290058770 \exp(-10\gamma\tau) + \\ &+ \gamma\tau(893885685 - 8300367075 \exp(-2\gamma\tau) + 31692310650 \times \\ &\times \exp(-4\gamma\tau) - 56442496110 \exp(-6\gamma\tau) + 47035413425 \times \\ &\times \exp(-8\gamma\tau) - 14835675855 \exp(-10\gamma\tau)). \end{aligned}$$

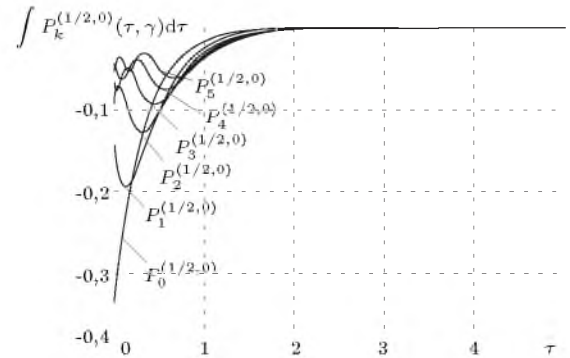

Рис. 1.97. Вид неопределенного интеграла 1-ого рода от ортогональных функций Якоби 0-5 порядков;  $\gamma = 2$ ,  $c = 2$ ,  $\alpha = 1/2$ ,  $\beta = 0$

$$\begin{aligned}
 [1.98] \quad & \int \tau^2 P_k^{(1/2,0)}(\tau, \gamma) d\tau = \\
 & = - \sum_{s=0}^k \binom{k}{s} \binom{k+s+1/2}{s+1/2} (-1)^s \exp\left(-\frac{(4s+3)}{2}\gamma\tau\right) \times \\
 & \quad \times \left( \frac{2\tau^2}{\gamma(4s+3)} + \frac{8\tau}{\gamma^2(4s+3)^2} + \frac{16}{\gamma^3(4s+3)^3} \right).
 \end{aligned}$$

Частные случаи для неопределенного интеграла 2-ого рода от функций 0-5 порядков:

$$\begin{aligned}
 \int \tau^2 P_0^{(1/2,0)}(\tau, \gamma) d\tau &= -\frac{2}{27\gamma^3} \exp\left(-\frac{3\gamma\tau}{2}\right) (9\gamma^2\tau^2 + 12\gamma\tau + 8); \\
 \int \tau^2 P_1^{(1/2,0)}(\tau, \gamma) d\tau &= -\frac{1}{3087\gamma^3} \exp\left(-\frac{3\gamma\tau}{2}\right) (2744 - 360 \times \\
 & \times \exp(-2\gamma\tau) + \gamma\tau(4116 - 1260 \exp(-2\gamma\tau) + \gamma^2\tau^2(3087 - 2205 \times \\
 & \times \exp(-2\gamma\tau))); \\
 \int \tau^2 P_2^{(1/2,0)}(\tau, \gamma) d\tau &= -\frac{1}{2347884\gamma^3} \exp\left(-\frac{3\gamma\tau}{2}\right) (2608760 - \\
 & - 958320 \exp(-2\gamma\tau) + 222264 \exp(-4\gamma\tau) + \gamma\tau(3913140 - \\
 & - 3354120 \exp(-2\gamma\tau) + 1222452 \exp(-4\gamma\tau)) + \gamma^2\tau^2(2934855 - \\
 & - 5869710 \exp(-2\gamma\tau) + 3361743 \exp(-4\gamma\tau))); \\
 \int \tau^2 P_3^{(1/2,0)}(\tau, \gamma) d\tau &= -\frac{1}{160083000\gamma^3} \exp\left(-\frac{3\gamma\tau}{2}\right) \times \\
 & \times (207515000 - 147015000 \exp(-2\gamma\tau) + 83349000 \exp(-4\gamma\tau) - \\
 & - 20348328 \exp(-6\gamma\tau) + \gamma\tau(311272500 - 514552500 \times \\
 & \times \exp(-2\gamma\tau) + 458419500 \exp(-4\gamma\tau) - 152612460 \times \\
 & \times \exp(-6\gamma\tau)) + \gamma^2\tau^2(233454375 - 900466875 \times \\
 & \times \exp(-2\gamma\tau) + 1260653625 \exp(-4\gamma\tau) - 572296725 \times \\
 & \times \exp(-6\gamma\tau)); \\
 \int \tau^2 P_4^{(1/2,0)}(\tau, \gamma) d\tau &= -\frac{1}{195201652800\gamma^3} \exp\left(-\frac{3\gamma\tau}{2}\right) \times \\
 & \times (284669077000 - 328655844000 \exp(-2\gamma\tau) + 330310234800 \times \\
 & \times \exp(-4\gamma\tau) - 186092242336 \exp(-6\gamma\tau) + 43240197000 \times \\
 & \times \exp(-8\gamma\tau) + \gamma\tau(427003615500 - 1150295454000 \exp(-2\gamma\tau) + \\
 & + 1816706291400 \exp(-4\gamma\tau) - 1395691817520 \exp(-6\gamma\tau) + \\
 & + 410781871500 \exp(-8\gamma\tau)) + \gamma^2\tau^2(320252711625 - \\
 & - 2013017044500 \exp(-2\gamma\tau) + 4995942301350 \exp(-4\gamma\tau) - \\
 & - 5233844315700 \exp(-6\gamma\tau) + 1951213889625 \exp(-8\gamma\tau)); \\
 \int \tau^2 P_5^{(1/2,0)}(\tau, \gamma) d\tau &= -\frac{1}{250001948380800\gamma^3} \exp\left(-\frac{3\gamma\tau}{2}\right) \times \\
 & \times (401044792194200 - 683997677649000 \exp(-2\gamma\tau) + \\
 & + 1057601217582000 \exp(-4\gamma\tau) - 1012924560856208 \times \\
 & \times \exp(-6\gamma\tau) + 526103476899000 \exp(-8\gamma\tau) -
 \end{aligned}$$

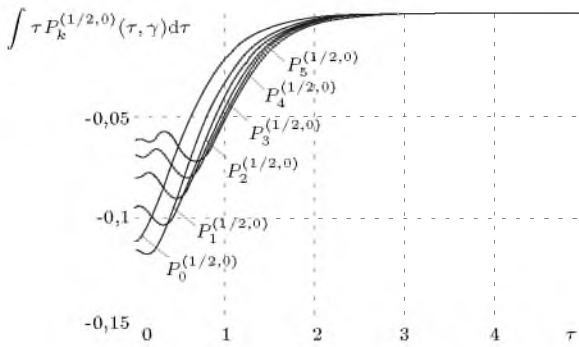
$$\begin{aligned}
 & - 113241358830600 \exp(-10\gamma\tau) + \gamma\tau(601567188291300 - \\
 & - 2393991871771500 \exp(-2\gamma\tau) + 5816806696701000 \times \\
 & \times \exp(-4\gamma\tau) - 7596934206421560 \exp(-6\gamma\tau) + \\
 & + 4997983030540500 \exp(-8\gamma\tau) - 1302275626551900 \times \\
 & \times \exp(-10\gamma\tau)) + \gamma^2\tau^2(451175391218475 - 4189485775600125 \times \\
 & \times \exp(-2\gamma\tau) + 15996218415927750 \exp(-4\gamma\tau) - \\
 & - 28488503274080850 \exp(-6\gamma\tau) + 4997983030540500 \times \\
 & \times \exp(-8\gamma\tau) - 1302275626551900 \exp(-10\gamma\tau)).
 \end{aligned}$$



Рис. 1.98. Вид неопределенного интеграла 2-ого рода от ортогональных функций Якоби 0-5 порядков;  $\gamma = 2$ ,  $c = 2$ ,  $\alpha = 1/2$ ,  $\beta = 0$

$$\begin{aligned}
 [1.99] \quad & \int \tau^3 P_k^{(1/2,0)}(\tau, \gamma) d\tau \\
 & = - \sum_{s=0}^k \binom{k}{s} \binom{k+s+1/2}{s+1/2} (-1)^s \exp\left(-\frac{(4s+3)}{2}\gamma\tau\right) \times \\
 & \times \left( \frac{2\tau^3}{\gamma(4s+3)} + \frac{12\tau^2}{\gamma^2(4s+3)^2} + \right. \\
 & \quad \left. + \frac{48\tau}{\gamma^3(4s+3)^3} + \frac{96}{\gamma^4(4s+3)^4} \right).
 \end{aligned}$$

Частные случаи для неопределенного интеграла 3-ого рода от функций 0-5 порядков:

$$\begin{aligned}
 \int \tau^3 P_0^{(1/2,0)}(\tau, \gamma) d\tau &= -\frac{2}{27\gamma^4} \exp\left(-\frac{3\gamma\tau}{2}\right) (9\gamma^3\tau^3 + 18\gamma^2\tau^2 + \\
 & + 24\gamma\tau + 16); \\
 \int \tau^3 P_1^{(1/2,0)}(\tau, \gamma) d\tau &= -\frac{1}{21609\gamma^4} \exp\left(-\frac{3\gamma\tau}{2}\right) (38416 - \\
 & - 2160 \times \exp(-2\gamma\tau) + \gamma\tau(57624 - 7560 \exp(-2\gamma\tau)) + \gamma^2\tau^2 \times \\
 & \times (43218 - 13230 \exp(-2\gamma\tau)) + \gamma^3\tau^3(21609 - 15435 \times \\
 & \times \exp(-2\gamma\tau))); \\
 \int \tau^3 P_2^{(1/2,0)}(\tau, \gamma) d\tau &= -\frac{1}{180787068\gamma^4} \exp\left(-\frac{3\gamma\tau}{2}\right) \times \\
 & \times (401749040 - 63249120 \exp(-2\gamma\tau) + 9335088 \exp(-4\gamma\tau) + \\
 & + \gamma\tau(602623560 - 221371920 \exp(-2\gamma\tau) + 51342984 \times \\
 & \times \exp(-4\gamma\tau)) + \gamma^2\tau^2(451967670 - 387400860 \exp(-2\gamma\tau) + \\
 & + 141193206 \exp(-4\gamma\tau)) + \gamma^3\tau^3(225983835 - 451967670 \times \\
 & \times \exp(-2\gamma\tau) + 258854211 \exp(-4\gamma\tau))); \\
 \int \tau^3 P_3^{(1/2,0)}(\tau, \gamma) d\tau &= -\frac{1}{61631955000\gamma^4} \exp\left(-\frac{3\gamma\tau}{2}\right) \times \\
 & \times (159786550000 - 48514950000 \exp(-2\gamma\tau) + \\
 & + 17503290000 \exp(-4\gamma\tau) - 3133642512 \exp(-6\gamma\tau) + \\
 & + \gamma\tau(239679825000 - 169802325000 \exp(-2\gamma\tau) + \\
 & + 96268095000 \exp(-4\gamma\tau) - 23502318840 \exp(-6\gamma\tau)) + \\
 & + \gamma^2\tau^2(179759868750 - 297154068750 \exp(-2\gamma\tau) + \\
 & + 264737261250 \exp(-4\gamma\tau) - 88133695650 \exp(-6\gamma\tau)) +
 \end{aligned}$$

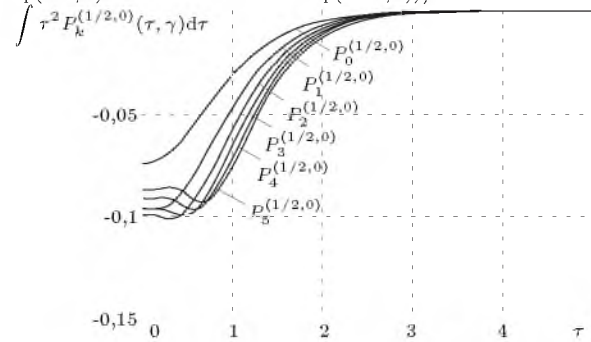
$$\begin{aligned}
 & + \gamma^3 \tau^3 (89879934375 - 346679746875 \exp(-2\gamma\tau) + \\
 & + 485351645625 \exp(-4\gamma\tau) - 220334239125 \exp(-6\gamma\tau)); \\
 & \int \tau^3 P_4^{(1/2,0)}(\tau, \gamma) d\tau = -\frac{1}{1427900090232000\gamma^4} \exp\left(-\frac{3\gamma\tau}{2}\right) \times \\
 & \times (4164708596510000 - 2060672141880000 \exp(-2\gamma\tau) + \\
 & + 1317937836852000 \exp(-4\gamma\tau) - 544505901075136 \times \\
 & \times \exp(-6\gamma\tau) + 99884855070000 \exp(-8\gamma\tau) + \gamma\tau \times \\
 & \times (6247062894765000 - 7212352496580000 \exp(-2\gamma\tau) + \\
 & + 7248658102686000 \exp(-4\gamma\tau) - 4083794258063520 \times \\
 & \times \exp(-6\gamma\tau) + 948906123165000 \exp(-8\gamma\tau)) + \gamma^2 \tau^2 \times \\
 & \times (4685297171073750 - 12621616869015000 \exp(-2\gamma\tau) + \\
 & + 19933809782386500 \exp(-4\gamma\tau) - 15314228467738200 \times \\
 & \times \exp(-6\gamma\tau) + 4507304085033750 \exp(-8\gamma\tau)) + \gamma^3 \tau^3 \times \\
 & \times (2342648585536875 - 14725219680517500 \exp(-2\gamma\tau) + \\
 & + 36545317934375250 \exp(-4\gamma\tau) - 38285571169345500 \times \\
 & \times \exp(-6\gamma\tau) + 14273129602606875 \exp(-8\gamma\tau)); \\
 & \int \tau^3 P_5^{(1/2,0)}(\tau, \gamma) d\tau = -\frac{1}{42061577805327696000\gamma^4} \times \\
 & \times \exp\left(-\frac{3\gamma\tau}{2}\right) (134947562125426358000 - \\
 & - 98639305093762290000 \exp(-2\gamma\tau) + 97056063737500140000 \times \\
 & \times \exp(-4\gamma\tau) - 68167797096501085984 \exp(-6\gamma\tau) + \\
 & + 27951877727643870000 \exp(-8\gamma\tau) - 4970163239075034000 \times \\
 & \times \exp(-10\gamma\tau) + \gamma\tau(202421343188139537000 - \\
 & - 345237567828168015000 \exp(-2\gamma\tau) + 533808350556250770000 \times \\
 & \times \exp(-4\gamma\tau) - 511258478223758144880 \exp(-6\gamma\tau) + \\
 & + 265542838412616765000 \exp(-8\gamma\tau) - 57156877249362891000 \times \\
 & \times \exp(-10\gamma\tau)) + \gamma^2 \tau^2 (151816007391104652750 - \\
 & - 604165743699294026250 \exp(-2\gamma\tau) + 1467972964029689617500 \times \\
 & \times \exp(-4\gamma\tau) - 1917219293339093043300 \exp(-6\gamma\tau) + \\
 & + 1261328482459929633750 \exp(-8\gamma\tau) - 328652044183836623250 \times \\
 & \times \exp(-10\gamma\tau)) + \gamma^3 \tau^3 (75908003695552326375 - \\
 & - 704860034315843030625 \exp(-2\gamma\tau) + 2691283767387764298750 \times \\
 & \times \exp(-4\gamma\tau) - 4793048233347732608250 \exp(-6\gamma\tau) + \\
 & + 3994206861123110506875 \exp(-8\gamma\tau) - \\
 & - 1259832836038040389125 \exp(-10\gamma\tau)).
 \end{aligned}$$



Рис. 1.99. Вид неопределенного интеграла 3-го рода от ортогональных функций Якоби 0-5 порядков;  $\gamma = 2$ ,  $c = 2$ ,  $\alpha = 1/2$ ,  $\beta = 0$

$$\begin{aligned}
 [1.100] \quad & \int \tau^n P_k^{(1/2,0)}(\tau, \gamma) d\tau = \\
 & = -\sum_{s=0}^k \binom{k}{s} \binom{k+s+1/2}{s+1/2} (-1)^s \exp\left(-\frac{(4s+3)\gamma\tau}{2}\right) \times \\
 & \times \sum_{j=0}^n \frac{n! \tau^{n-j}}{(n-j)! \left(\frac{\gamma(4s+3)}{2}\right)^{j+1}}.
 \end{aligned}$$

Частные случаи для неопределенного интеграла n-го рода от функций 0-5 порядков:

$$\int \tau^n P_0^{(1/2,0)}(\tau, \gamma) d\tau = -\frac{2n!}{3\gamma} \exp\left(-\frac{3\gamma\tau}{2}\right) \sum_{j=0}^n \left(\frac{2}{3\gamma}\right)^j \frac{\tau^{n-j}}{(n-j)!};$$

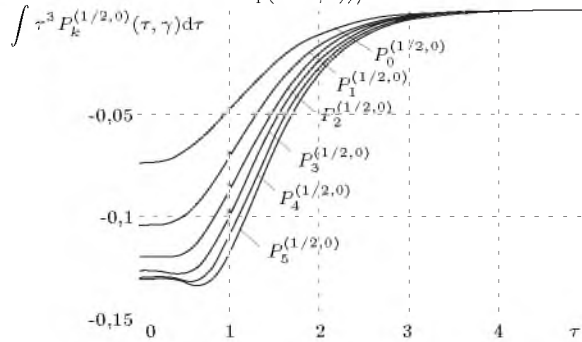
$$\int \tau^n P_1^{(1/2,0)}(\tau, \gamma) d\tau = -\exp\left(-\frac{3\gamma\tau}{2}\right) \times$$

$$\times \left( \frac{3n!}{2} \sum_{j=0}^n \frac{\tau^{n-j}}{(n-j)! \left(\frac{3\gamma}{2}\right)^{j+1}} - \right.$$

$$\left. - \frac{5n!}{2} \exp(-2\gamma\tau) \sum_{j=0}^n \frac{\tau^{n-j}}{(n-j)! \left(\frac{7\gamma}{2}\right)^{j+1}} \right);$$

$$\int \tau^n P_2^{(1/2,0)}(\tau, \gamma) d\tau = -\exp\left(-\frac{3\gamma\tau}{2}\right) \times$$

$$\times \left( \frac{15n!}{8} \sum_{j=0}^n \frac{\tau^{n-j}}{(n-j)! \left(\frac{3\gamma}{2}\right)^{j+1}} - \right.$$

$$\left. - \frac{35n!}{4} \exp(-2\gamma\tau) \sum_{j=0}^n \frac{\tau^{n-j}}{(n-j)! \left(\frac{7\gamma}{2}\right)^{j+1}} + \right.$$

$$\left. + \frac{63n!}{8} \exp(-4\gamma\tau) \sum_{j=0}^n \frac{\tau^{n-j}}{(n-j)! \left(\frac{11\gamma}{2}\right)^{j+1}} \right);$$

$$\int \tau^n P_3^{(1/2,0)}(\tau, \gamma) d\tau = -\exp\left(-\frac{3\gamma\tau}{2}\right) \times$$

$$\times \left( \frac{35n!}{16} \sum_{j=0}^n \frac{\tau^{n-j}}{(n-j)! \left(\frac{3\gamma}{2}\right)^{j+1}} - \right.$$

$$\left. - \frac{315n!}{16} \exp(-2\gamma\tau) \sum_{j=0}^n \frac{\tau^{n-j}}{(n-j)! \left(\frac{7\gamma}{2}\right)^{j+1}} + \right.$$

$$\left. + \frac{693n!}{16} \exp(-4\gamma\tau) \sum_{j=0}^n \frac{\tau^{n-j}}{(n-j)! \left(\frac{11\gamma}{2}\right)^{j+1}} - \right.$$

$$\left. - \frac{429n!}{16} \exp(-6\gamma\tau) \sum_{j=0}^n \frac{\tau^{n-j}}{(n-j)! \left(\frac{15\gamma}{2}\right)^{j+1}} \right);$$

$$\int \tau^n P_4^{(1/2,0)}(\tau, \gamma) d\tau = -\exp\left(-\frac{3\gamma\tau}{2}\right) \times$$

$$\times \left( \frac{315n!}{128} \sum_{j=0}^n \frac{\tau^{n-j}}{(n-j)! \left(\frac{3\gamma}{2}\right)^{j+1}} - \right.$$

$$\begin{aligned}
& - \frac{1155n!}{32} \exp(-2\gamma\tau) \sum_{j=0}^n \frac{\tau^{n-j}}{(n-j)! \left(\frac{7\gamma}{2}\right)^{j+1}} + \\
& + \frac{9009n!}{64} \exp(-4\gamma\tau) \sum_{j=0}^n \frac{\tau^{n-j}}{(n-j)! \left(\frac{11\gamma}{2}\right)^{j+1}} - \\
& - \frac{6435n!}{32} \exp(-6\gamma\tau) \sum_{j=0}^n \frac{\tau^{n-j}}{(n-j)! \left(\frac{15\gamma}{2}\right)^{j+1}} + \\
& + \frac{12155n!}{128} \exp(-8\gamma\tau) \sum_{j=0}^n \frac{\tau^{n-j}}{(n-j)! \left(\frac{19\gamma}{2}\right)^{j+1}} \Bigg); \\
& \int \tau^n P_5^{(1/2,0)}(\tau, \gamma) d\tau = -\exp\left(-\frac{37\gamma\tau}{2}\right) \times \\
& \times \left( \frac{693n!}{256} \sum_{j=0}^n \frac{\tau^{n-j}}{(n-j)! \left(\frac{3\gamma}{2}\right)^{j+1}} - \right. \\
& - \frac{15015n!}{256} \exp(-2\gamma\tau) \sum_{j=0}^n \frac{\tau^{n-j}}{(n-j)! \left(\frac{7\gamma}{2}\right)^{j+1}} + \\
& + \frac{45045n!}{128} \exp(-4\gamma\tau) \sum_{j=0}^n \frac{\tau^{n-j}}{(n-j)! \left(\frac{11\gamma}{2}\right)^{j+1}} - \\
& - \frac{109395n!}{128} \exp(-6\gamma\tau) \sum_{j=0}^n \frac{\tau^{n-j}}{(n-j)! \left(\frac{15\gamma}{2}\right)^{j+1}} + \\
& + \frac{230945n!}{256} \exp(-8\gamma\tau) \sum_{j=0}^n \frac{\tau^{n-j}}{(n-j)! \left(\frac{19\gamma}{2}\right)^{j+1}} - \\
& \left. - \frac{88179n!}{256} \exp(-10\gamma\tau) \sum_{j=0}^n \frac{\tau^{n-j}}{(n-j)! \left(\frac{23\gamma}{2}\right)^{j+1}} \right). \\
& \int \tau^n P_k^{(1/2,0)}(\tau, \gamma) d\tau
\end{aligned}$$

Рис. 1.100. Вид неопределенного интеграла n-ого рода от ортогональных функций Якоби 2-ого порядка;  $n = 0..5$ ,  $\gamma = 2$ ,  $c = 2$ ,  $\alpha = 1/2$ ,  $\beta = 0$

$$\begin{aligned}
[1.101] \quad \int P_k^{(1,0)}(\tau, \gamma) d\tau &= - \sum_{s=0}^k \binom{k}{s} \binom{k+s+1}{s+1} \times \\
& \times \frac{(-1)^s}{\gamma(s+1)} \exp(-(s+1)\gamma\tau).
\end{aligned}$$

Частные случаи для неопределенного интеграла от функций 0-5 порядков:

$$\begin{aligned}
\int P_0^{(1,0)}(\tau, \gamma) d\tau &= -\frac{1}{\gamma} \exp(-\gamma\tau); \\
\int P_1^{(1,0)}(\tau, \gamma) d\tau &= -\frac{1}{2\gamma} \exp(-\gamma\tau)(4 - 3 \exp(-\gamma\tau)); \\
\int P_2^{(1,0)}(\tau, \gamma) d\tau &= -\frac{1}{3\gamma} \exp(-\gamma\tau)(9 - 18 \exp(-\gamma\tau) + 10 \times \\
& \times \exp(-2\gamma\tau)); \\
\int P_3^{(1,0)}(\tau, \gamma) d\tau &= -\frac{1}{4\gamma} \exp(-\gamma\tau)(16 - 60 \exp(-\gamma\tau) + 80 \times \\
& \times \exp(-2\gamma\tau) - 35 \exp(-3\gamma\tau)); \\
\int P_4^{(1,0)}(\tau, \gamma) d\tau &= -\frac{1}{5\gamma} \exp(-\gamma\tau)(25 - 150 \exp(-\gamma\tau) + 350 \times \\
& \times \exp(-2\gamma\tau) - 350 \exp(-3\gamma\tau) + 126 \exp(-4\gamma\tau)); \\
\int P_5^{(1,0)}(\tau, \gamma) d\tau &= -\frac{1}{6\gamma} \exp(-\gamma\tau)(36 - 315 \exp(-\gamma\tau) + 1120 \times \\
& \times \exp(-2\gamma\tau) - 1890 \exp(-3\gamma\tau) + 1512 \exp(-4\gamma\tau) - 462 \times \\
& \times \exp(-5\gamma\tau)).
\end{aligned}$$



Рис. 1.101. Вид неопределенного интеграла от ортогональных функций Якоби 0-5 порядков;  $\gamma = 2$ ,  $c = 1$ ,  $\alpha = 1$ ,  $\beta = 0$

$$\begin{aligned}
[1.102] \quad \int \tau P_k^{(1,0)}(\tau, \gamma) d\tau &= - \sum_{s=0}^k \binom{k}{s} \binom{k+s+1}{s+1} \times \\
& \times (-1)^s \exp(-(s+1)\gamma\tau) \left( \frac{\tau}{\gamma(s+1)} + \frac{1}{\gamma^2(s+1)^2} \right).
\end{aligned}$$

Частные случаи для неопределенного интеграла 1-ого рода от функций 0-5 порядков:

$$\begin{aligned}
\int \tau P_0^{(1,0)}(\tau, \gamma) d\tau &= -\frac{1}{\gamma^2} \exp(-\gamma\tau)(\gamma\tau + 1); \\
\int \tau P_1^{(1,0)}(\tau, \gamma) d\tau &= -\frac{1}{4\gamma^2} \exp(-\gamma\tau)(8 - 3 \exp(-\gamma\tau) + \gamma\tau(8 - \\
& - 6 \exp(-\gamma\tau))); \\
\int \tau P_2^{(1,0)}(\tau, \gamma) d\tau &= -\frac{1}{9\gamma^2} \exp(-\gamma\tau)(27 - 27 \exp(-\gamma\tau) + 10 \times \\
& \times \exp(-2\gamma\tau) + \gamma\tau(27 - 54 \exp(-\gamma\tau) + 30 \exp(-2\gamma\tau))); \\
\int \tau P_3^{(1,0)}(\tau, \gamma) d\tau &= -\frac{1}{48\gamma^2} \exp(-\gamma\tau)(192 - 360 \exp(-\gamma\tau) + \\
& + 320 \exp(-2\gamma\tau) - 105 \exp(-3\gamma\tau) + \gamma\tau(192 - 720 \exp(-\gamma\tau) + \\
& + 960 \exp(-2\gamma\tau) - 420 \exp(-3\gamma\tau)));
\end{aligned}$$

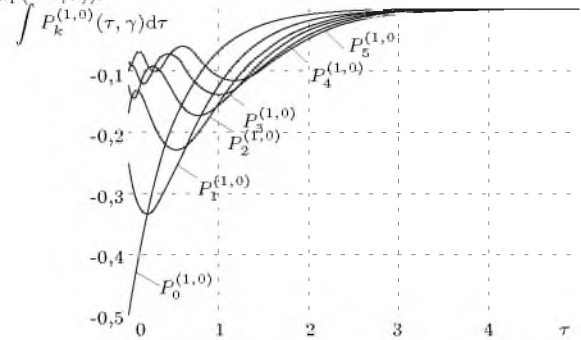

Рис. 1.102. Вид неопределенного интеграла 1-ого рода от ортогональных функций Якоби 0-5 порядков;  $\gamma = 2$ ,  $c = 1$ ,  $\alpha = 1$ ,  $\beta = 0$

$$[1.103] \int \tau^2 P_k^{(1,0)}(\tau, \gamma) d\tau = - \sum_{s=0}^k \binom{k}{s} \binom{k+s+1}{s+1} \times (-1)^s \exp(-(s+1)\gamma\tau) \left( \frac{\tau^2}{\gamma(s+1)} + \frac{2\tau}{\gamma^2(s+1)^2} + \frac{2}{\gamma^3(s+1)^3} \right).$$

Частные случаи для неопределенного интеграла 2-ого рода от функций 0-5 порядков:

$$\begin{aligned} \int \tau^2 P_0^{(1,0)}(\tau, \gamma) d\tau &= -\frac{1}{\gamma^3} \exp(-\gamma\tau)(\gamma^2\tau^2 + 2\gamma\tau + 2); \\ \int \tau^2 P_1^{(1,0)}(\tau, \gamma) d\tau &= -\frac{1}{4\gamma^3} \exp(-\gamma\tau)(16 - 3\exp(-\gamma\tau) + \gamma\tau(16 - 6\exp(-\gamma\tau) + \gamma^2\tau^2(8 - 6\exp(-\gamma\tau))); \\ \int \tau^2 P_2^{(1,0)}(\tau, \gamma) d\tau &= -\frac{1}{27\gamma^3} \exp(-\gamma\tau)(162 - 81\exp(-\gamma\tau) + 20\exp(-2\gamma\tau) + \gamma\tau(162 - 162\exp(-\gamma\tau) + 60\exp(-2\gamma\tau)) + \gamma^2\tau^2(81 - 162\exp(-\gamma\tau) + 90\exp(-2\gamma\tau))); \\ \int \tau^2 P_3^{(1,0)}(\tau, \gamma) d\tau &= -\frac{1}{288\gamma^3} \exp(-\gamma\tau)(2304 - 2160 \times \exp(-\gamma\tau) + 1280\exp(-2\gamma\tau) - 315\exp(-3\gamma\tau) + \gamma\tau(2304 - 4320\exp(-\gamma\tau) + 3840\exp(-2\gamma\tau) - 1260\exp(-3\gamma\tau)) + \gamma^2\tau^2(1152 - 4320\exp(-\gamma\tau) + 5760\exp(-2\gamma\tau) - 2520 \times \exp(-3\gamma\tau))); \\ \int \tau^2 P_4^{(1,0)}(\tau, \gamma) d\tau &= -\frac{1}{4500\gamma^3} \exp(-\gamma\tau)(45000 - 67500 \times \exp(-\gamma\tau) + 70000\exp(-2\gamma\tau) - 39375\exp(-3\gamma\tau) + 9072 \times \exp(-4\gamma\tau) + \gamma\tau(45000 - 135000\exp(-\gamma\tau) + 210000 \times \exp(-2\gamma\tau) - 157500\exp(-3\gamma\tau) + 45360\exp(-4\gamma\tau)) + \gamma^2\tau^2 \times (22500 - 135000\exp(-\gamma\tau) + 315000\exp(-2\gamma\tau) - 315000 \times \end{aligned}$$

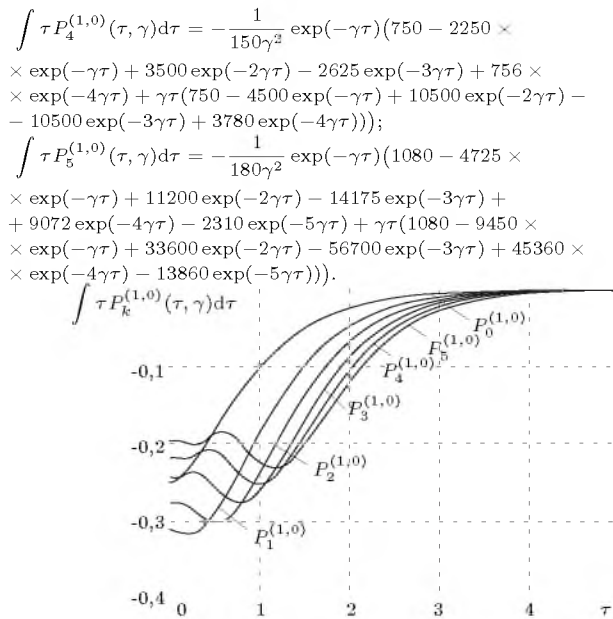

Рис. 1.103. Вид неопределенного интеграла 2-ого рода от ортогональных функций Якоби 0-5 порядков;  $\gamma = 2$ ,  $c = 1$ ,  $\alpha = 1$ ,  $\beta = 0$

$$[1.104] \int \tau^3 P_k^{(1,0)}(\tau, \gamma) d\tau = - \sum_{s=0}^k \binom{k}{s} \binom{k+s+1}{s+1} \times (-1)^s \exp(-(s+1)\gamma\tau) \left( \frac{\tau^3}{\gamma(s+1)} + \frac{3\tau^2}{\gamma^2(s+1)^2} + \frac{6\tau}{\gamma^3(s+1)^3} + \frac{6}{\gamma^4(s+1)^4} \right).$$

Частные случаи для неопределенного интеграла 3-ого рода от функций 0-5 порядков:

$$\begin{aligned} \int \tau^3 P_0^{(1,0)}(\tau, \gamma) d\tau &= -\frac{1}{\gamma^4} \exp(-\gamma\tau)(\gamma^3\tau^3 + 3\gamma^2\tau^2 + 6\gamma\tau + 6); \\ \int \tau^3 P_1^{(1,0)}(\tau, \gamma) d\tau &= -\frac{1}{8\gamma^4} \exp(-\gamma\tau)(96 - 9\exp(-\gamma\tau) + \gamma\tau(96 - 18\exp(-\gamma\tau) + \gamma^2\tau^2(48 - 18\exp(-\gamma\tau)) + \gamma^3\tau^3(16 - 12\exp(-\gamma\tau))); \\ \int \tau^3 P_2^{(1,0)}(\tau, \gamma) d\tau &= -\frac{1}{54\gamma^4} \exp(-\gamma\tau)(972 - 243\exp(-\gamma\tau) + 40\exp(-2\gamma\tau) + \gamma\tau(972 - 486\exp(-\gamma\tau) + 120\exp(-2\gamma\tau)) + \gamma^2\tau^2(486 - 486\exp(-\gamma\tau) + 180\exp(-2\gamma\tau)) + \gamma^3\tau^3(162 - 324\exp(-\gamma\tau) + 180\exp(-2\gamma\tau))); \\ \int \tau^3 P_3^{(1,0)}(\tau, \gamma) d\tau &= -\frac{1}{1152\gamma^4} \exp(-\gamma\tau)(27648 - 12960 \times \exp(-\gamma\tau) + 5120\exp(-2\gamma\tau) - 945\exp(-3\gamma\tau) + \gamma\tau(27648 - 25920\exp(-\gamma\tau) + 15360\exp(-2\gamma\tau) - 3780\exp(-3\gamma\tau)) + \gamma^2\tau^2(13824 - 25920\exp(-\gamma\tau) + 23040\exp(-2\gamma\tau) - 7560 \times \exp(-3\gamma\tau)) + \gamma^3\tau^3(4608 - 17280\exp(-\gamma\tau) + 23040 \times \exp(-2\gamma\tau) - 10080\exp(-3\gamma\tau))); \\ \int \tau^3 P_4^{(1,0)}(\tau, \gamma) d\tau &= -\frac{1}{90000\gamma^4} \exp(-\gamma\tau)(2700000 - 2025000\exp(-\gamma\tau) + 1400000\exp(-2\gamma\tau) - 590625 \times \exp(-3\gamma\tau) + 108864\exp(-4\gamma\tau) + \gamma\tau(2700000 - 4050000 \times \exp(-\gamma\tau) + 4200000\exp(-2\gamma\tau) - 2362500\exp(-3\gamma\tau) + 544320\exp(-4\gamma\tau)) + \gamma^2\tau^2(1350000 - 4050000\exp(-\gamma\tau) + \end{aligned}$$

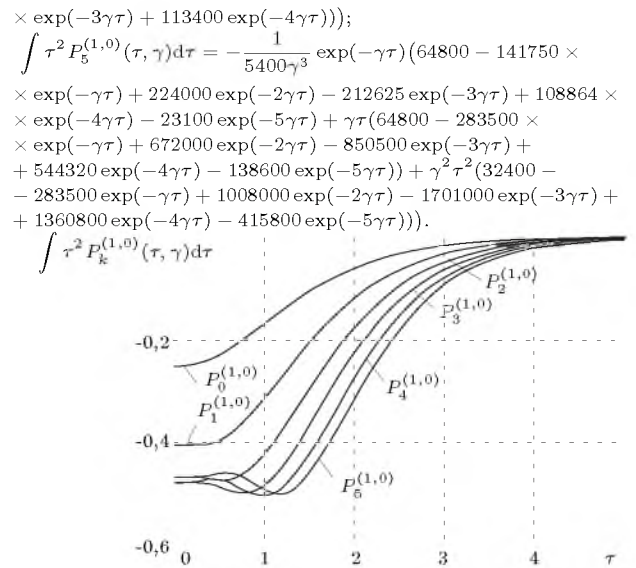

Рис. 1.104. Вид неопределенного интеграла 3-ого рода от ортогональных функций Якоби 0-5 порядков;  $\gamma = 2, c = 1, \alpha = 1, \beta = 0$

$$[1.105] \quad \int \tau^n P_k^{(1,0)}(\tau, \gamma) d\tau = - \sum_{s=0}^k \binom{k}{s} \binom{k+s+1}{s+1} \times (-1)^s \exp(-(s+1)\gamma\tau) \sum_{j=0}^n \frac{n! \tau^{n-j}}{(n-j)! (\gamma(s+1))^{j+1}}.$$

Частные случаи для неопределенного интеграла n-ого рода от функций 0-5 порядков:

$$\int \tau^n P_0^{(1,0)}(\tau, \gamma) d\tau = - \frac{2n!}{\gamma} \exp(-\gamma\tau) \sum_{j=0}^n \left(\frac{2}{\gamma}\right)^j \frac{\tau^{n-j}}{(n-j)!};$$

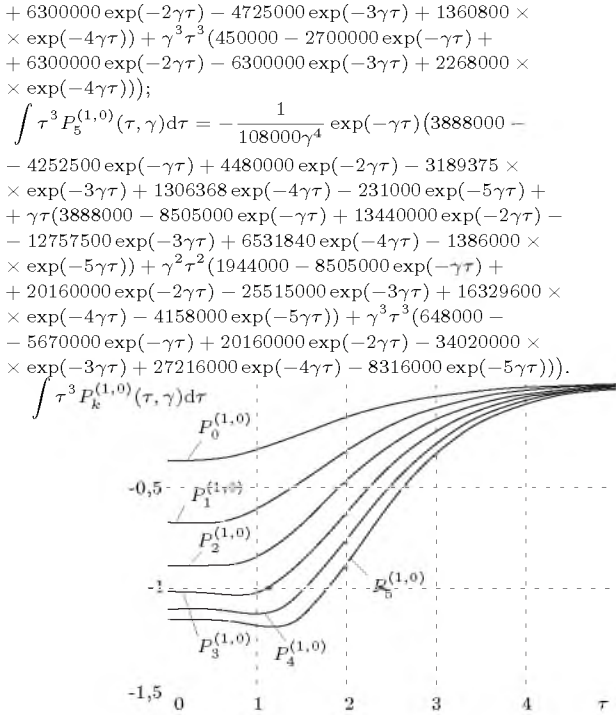
$$\int \tau^n P_1^{(1,0)}(\tau, \gamma) d\tau = - \exp(-\gamma\tau) \times$$

$$\times \left( 2n! \sum_{j=0}^n \frac{\tau^{n-j}}{(n-j)! (\gamma)^{j+1}} - n! \exp(-\gamma\tau) \sum_{j=0}^n \frac{\tau^{n-j}}{(n-j)! (2\gamma)^{j+1}} \right);$$

$$\int \tau^n P_2^{(1,0)}(\tau, \gamma) d\tau = - \exp(-\gamma\tau) \times$$

$$\times \left( 3n! \sum_{j=0}^n \frac{\tau^{n-j}}{(n-j)! (\gamma)^{j+1}} - 12n! \exp(-\gamma\tau) \sum_{j=0}^n \frac{\tau^{n-j}}{(n-j)! (2\gamma)^{j+1}} + \right.$$

$$\left. + 10n! \exp(-2\gamma\tau) \sum_{j=0}^n \frac{\tau^{n-j}}{(n-j)! (3\gamma)^{j+1}} \right);$$

$$\int \tau^n P_3^{(1,0)}(\tau, \gamma) d\tau = - \exp(-\gamma\tau) \times$$

$$\times \left( 4n! \sum_{j=0}^n \frac{\tau^{n-j}}{(n-j)! (\gamma)^{j+1}} - 30n! \exp(-\gamma\tau) \sum_{j=0}^n \frac{\tau^{n-j}}{(n-j)! (2\gamma)^{j+1}} + \right.$$

$$+ 60n! \exp(-2\gamma\tau) \sum_{j=0}^n \frac{\tau^{n-j}}{(n-j)! (3\gamma)^{j+1}} -$$

$$- 35n! \exp(-3\gamma\tau) \sum_{j=0}^n \frac{\tau^{n-j}}{(n-j)! (4\gamma)^{j+1}} \Big);$$

$$\int \tau^n P_4^{(1,0)}(\tau, \gamma) d\tau = - \exp(-\gamma\tau) \times$$

$$\times \left( 5n! \sum_{j=0}^n \frac{\tau^{n-j}}{(n-j)! (\gamma)^{j+1}} - 60n! \exp(-\gamma\tau) \sum_{j=0}^n \frac{\tau^{n-j}}{(n-j)! (2\gamma)^{j+1}} + \right.$$

$$+ 210n! \exp(-2\gamma\tau) \sum_{j=0}^n \frac{\tau^{n-j}}{(n-j)! (3\gamma)^{j+1}} -$$

$$- 280n! \exp(-3\gamma\tau) \sum_{j=0}^n \frac{\tau^{n-j}}{(n-j)! (4\gamma)^{j+1}} +$$

$$+ 126n! \exp(-4\gamma\tau) \sum_{j=0}^n \frac{\tau^{n-j}}{(n-j)! (5\gamma)^{j+1}} \Big);$$

$$\int \tau^n P_5^{(1,0)}(\tau, \gamma) d\tau = - \exp(-\gamma\tau) \times$$

$$\times \left( 6n! \sum_{j=0}^n \frac{\tau^{n-j}}{(n-j)! (\gamma)^{j+1}} - 105n! \exp(-\gamma\tau) \sum_{j=0}^n \frac{\tau^{n-j}}{(n-j)! (2\gamma)^{j+1}} + \right.$$

$$+ 560n! \exp(-2\gamma\tau) \sum_{j=0}^n \frac{\tau^{n-j}}{(n-j)! (3\gamma)^{j+1}} -$$

$$- 1260n! \exp(-3\gamma\tau) \sum_{j=0}^n \frac{\tau^{n-j}}{(n-j)! (4\gamma)^{j+1}} +$$

$$+ 1260n! \exp(-4\gamma\tau) \sum_{j=0}^n \frac{\tau^{n-j}}{(n-j)! (5\gamma)^{j+1}} -$$

$$- 462n! \exp(-5\gamma\tau) \sum_{j=0}^n \frac{\tau^{n-j}}{(n-j)! (6\gamma)^{j+1}} \Big).$$





Рис. 1.105. Вид неопределенного интеграла n-ого рода от ортогональных функций Якоби 2-ого порядка;  $n = 0..5$ ,  $\gamma = 2$ ,  $c = 1$ ,  $\alpha = 1$ ,  $\beta = 0$

$$[1.106] \quad \int P_k^{(2,0)}(\tau, \gamma) d\tau = - \sum_{s=0}^k \binom{k}{s} \binom{k+s+2}{s+2} \times \\ \times \frac{(-1)^s}{\gamma(2s+3)} \exp(-(2s+3)\gamma\tau).$$

Частные случаи для неопределенного интеграла от функций 0-5 порядков:

$$\int P_0^{(2,0)}(\tau, \gamma) d\tau = -\frac{1}{3\gamma} \exp(-3\gamma\tau);$$

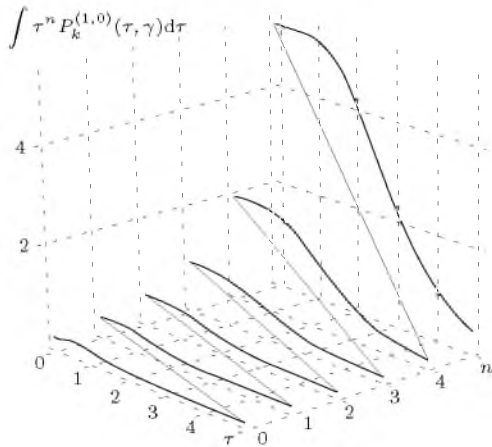
$$\int P_1^{(2,0)}(\tau, \gamma) d\tau = -\frac{1}{5\gamma} \exp(-3\gamma\tau)(5 - 4 \exp(-2\gamma\tau));$$

$$\int P_2^{(2,0)}(\tau, \gamma) d\tau = -\frac{1}{7\gamma} \exp(-3\gamma\tau)(14 - 28 \exp(-2\gamma\tau) + 15 \times \\ \times \exp(-4\gamma\tau));$$

$$\int P_3^{(2,0)}(\tau, \gamma) d\tau = -\frac{1}{9\gamma} \exp(-3\gamma\tau)(30 - 56 \exp(-2\gamma\tau) + 108 \times \\ \times \exp(-4\gamma\tau) - 135 \exp(-6\gamma\tau));$$

$$\int P_4^{(2,0)}(\tau, \gamma) d\tau = -\frac{1}{11\gamma} \exp(-3\gamma\tau)(55 - 308 \exp(-2\gamma\tau) + \\ + 660 \exp(-4\gamma\tau) - 616 \exp(-6\gamma\tau) + 210 \exp(-8\gamma\tau));$$

$$\int P_5^{(2,0)}(\tau, \gamma) d\tau = -\frac{1}{13\gamma} \exp(-3\gamma\tau)(91 - 728 \exp(-2\gamma\tau) + \\ + 2340 \exp(-4\gamma\tau) - 3640 \exp(-6\gamma\tau) + 2730 \exp(-8\gamma\tau) - 792 \times \\ \times \exp(-10\gamma\tau)).$$



Рис. 1.106. Вид неопределенного интеграла от ортогональных функций Якоби 0-5 порядков;  $\gamma = 2$ ,  $c = 2$ ,  $\alpha = 2$ ,  $\beta = 0$

$$[1.107] \quad \int \tau P_k^{(2,0)}(\tau, \gamma) d\tau = - \sum_{s=0}^k \binom{k}{s} \binom{k+s+2}{s+2} \times \\ \times (-1)^s \exp(-(2s+3)\gamma\tau) \left( \frac{\tau}{\gamma(2s+3)} + \frac{1}{\gamma^2(2s+3)^2} \right).$$

Частные случаи для неопределенного интеграла 1-ого рода от функций 0-5 порядков:

$$\int \tau P_0^{(2,0)}(\tau, \gamma) d\tau = -\frac{1}{9\gamma^2} \exp(-3\gamma\tau)(3\gamma\tau + 1);$$

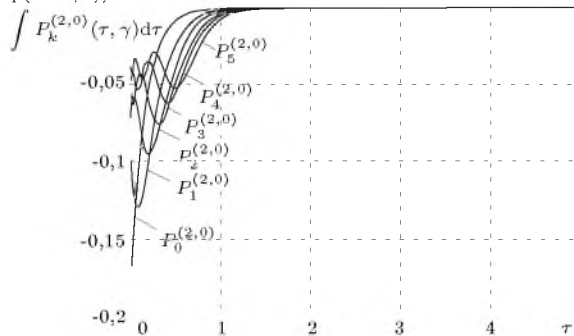
$$\int \tau P_1^{(2,0)}(\tau, \gamma) d\tau = -\frac{1}{75\gamma^2} \exp(-3\gamma\tau)(25 - 12 \exp(-2\gamma\tau) + \\ + \gamma\tau(75 - 60 \exp(-2\gamma\tau)));$$

$$\int \tau P_2^{(2,0)}(\tau, \gamma) d\tau = -\frac{1}{735\gamma^2} \exp(-3\gamma\tau)(490 - 588 \times \\ \times \exp(-2\gamma\tau) + 225 \exp(-4\gamma\tau) + \gamma\tau(1470 - 2940 \exp(-2\gamma\tau) + \\ + 1575 \exp(-4\gamma\tau)));$$

$$\int \tau P_3^{(2,0)}(\tau, \gamma) d\tau = -\frac{1}{2835\gamma^2} \exp(-3\gamma\tau)(3150 - 6804 \times \\ \times \exp(-2\gamma\tau) + 6075 \exp(-4\gamma\tau) - 1960 \exp(-6\gamma\tau) + \gamma\tau(9450 - \\ - 34020 \exp(-2\gamma\tau) + 42535 \exp(-4\gamma\tau) - 17640 \exp(-6\gamma\tau)));$$

$$\int \tau P_4^{(2,0)}(\tau, \gamma) d\tau = -\frac{1}{38115\gamma^2} \exp(-3\gamma\tau)(63525 - 213444 \times \\ \times \exp(-2\gamma\tau) + 326700 \exp(-4\gamma\tau) - 237160 \exp(-6\gamma\tau) + \\ + 66150 \exp(-8\gamma\tau) + \gamma\tau(190575 - 1067220 \exp(-2\gamma\tau) + \\ + 2286900 \exp(-4\gamma\tau) - 2134440 \exp(-6\gamma\tau) + 727650 \exp(-8\gamma\tau)));$$

$$\int \tau P_5^{(2,0)}(\tau, \gamma) d\tau = -\frac{1}{585585\gamma^2} \exp(-3\gamma\tau)(1366365 - \\ - 6558552 \exp(-2\gamma\tau) + 15057900 \exp(-4\gamma\tau) - 18218200 \times \\ \times \exp(-6\gamma\tau) + 11179350 \exp(-8\gamma\tau) - 2744280 \exp(-10\gamma\tau) + \\ + \gamma\tau(4099095 - 32792760 \exp(-2\gamma\tau) + 105405300 \exp(-4\gamma\tau) - \\ + 163963800 \exp(-6\gamma\tau) + 122972850 \exp(-8\gamma\tau) - 35675640 \times \\ \times \exp(-10\gamma\tau))).$$



Рис. 1.107. Вид неопределенного интеграла 1-ого рода от ортогональных функций Якоби 0-5 порядков;  $\gamma = 2$ ,  $c = 2$ ,  $\alpha = 2$ ,  $\beta = 0$

$$[1.108] \quad \int \tau^2 P_k^{(2,0)}(\tau, \gamma) d\tau = - \sum_{s=0}^k \binom{k}{s} \binom{k+s+2}{s+2} \times \\ \times (-1)^s \exp(-(2s+3)\gamma\tau) \left( \frac{\tau^2}{\gamma(2s+3)} + \frac{2\tau}{\gamma^2(2s+3)^2} + \frac{2}{\gamma^3(2s+3)^3} \right).$$

Частные случаи для неопределенного интеграла 2-ого рода от функций 0-5 порядков:

$$\int \tau^2 P_0^{(2,0)}(\tau, \gamma) d\tau = -\frac{1}{27\gamma^3} \exp(-3\gamma\tau)(9\gamma^2\tau^2 + 6\gamma\tau + 2);$$

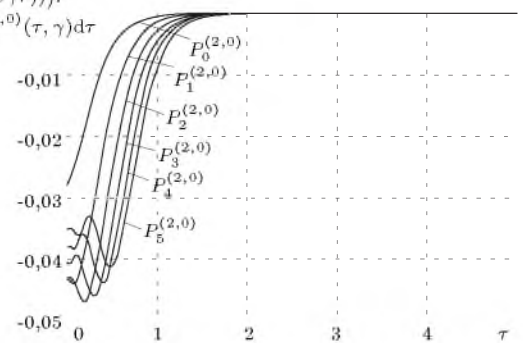
$$\int \tau^2 P_1^{(2,0)}(\tau, \gamma) d\tau = -\frac{1}{1125\gamma^3} \exp(-3\gamma\tau)(250 - 72 \times \exp(-2\gamma\tau) + \gamma\tau(750 - 360 \exp(-2\gamma\tau) + \gamma^2\tau^2(1125 - 900 \times \exp(-2\gamma\tau)));$$

$$\int \tau^2 P_2^{(2,0)}(\tau, \gamma) d\tau = -\frac{1}{77175\gamma^3} \exp(-3\gamma\tau)(34300 - 24696 \times \exp(-2\gamma\tau) + 6750 \exp(-4\gamma\tau) + \gamma\tau(102900 - 123480 \times \exp(-2\gamma\tau) + 47250 \exp(-4\gamma\tau)) + \gamma^2\tau^2(154350 - 308700 \times \exp(-2\gamma\tau) + 165375 \exp(-4\gamma\tau)));$$

$$\int \tau^2 P_3^{(2,0)}(\tau, \gamma) d\tau = -\frac{1}{893025\gamma^3} \exp(-3\gamma\tau)(661500 - 857304 \exp(-2\gamma\tau) + 546750 \exp(-4\gamma\tau) - 137200 \exp(-6\gamma\tau) + \gamma\tau(1984500 - 4286520 \exp(-2\gamma\tau) + 3827250 \exp(-4\gamma\tau) - 1234800 \exp(-6\gamma\tau)) + \gamma^2\tau^2(2976750 - 10716300 \exp(-2\gamma\tau) + 13395375 \exp(-4\gamma\tau) - 5556600 \exp(-6\gamma\tau)));$$

$$\int \tau^2 P_4^{(2,0)}(\tau, \gamma) d\tau = -\frac{1}{132068475\gamma^3} \exp(-3\gamma\tau)(146742750 - 295833384 \exp(-2\gamma\tau) + 323433000 \exp(-4\gamma\tau) - 182613200 \times \exp(-6\gamma\tau) + 41674500 \exp(-8\gamma\tau) + \gamma\tau(440228250 - 1479166920 \exp(-2\gamma\tau) + 2264031000 \exp(-4\gamma\tau) - 1643518800 \exp(-6\gamma\tau) + 458419500 \exp(-8\gamma\tau)) + \gamma^2\tau^2(660342375 - 3697917300 \exp(-2\gamma\tau) + 7924108500 \times \exp(-4\gamma\tau) - 7395834600 \exp(-6\gamma\tau) + 2521307250 \times \exp(-8\gamma\tau)));$$

$$\int \tau^2 P_5^{(2,0)}(\tau, \gamma) d\tau = -\frac{1}{26377676325\gamma^3} \exp(-3\gamma\tau) \times (41031940950 - 118171989936 \exp(-2\gamma\tau) + 193795173000 \times \exp(-4\gamma\tau) - 182364182000 \exp(-6\gamma\tau) + 91558876500 \times \exp(-8\gamma\tau) - 19017860400 \exp(-10\gamma\tau) + \gamma\tau(123095822850 - 590859949680 \exp(-2\gamma\tau) + 1356566211000 \exp(-4\gamma\tau) - 1641277638000 \exp(-6\gamma\tau) + 1007147641500 \exp(-8\gamma\tau) - 247232185200 \exp(-10\gamma\tau)) + \gamma^2\tau^2(184643734275 - 1477149874200 \exp(-2\gamma\tau) + 4747981738500 \exp(-4\gamma\tau) - 7385749371000 \exp(-6\gamma\tau) + 5539312028250 \exp(-8\gamma\tau) - 1607009203800 \exp(-10\gamma\tau)).$$



Рис. 1.108. Вид неопределенного интеграла 2-ого рода от ортогональных функций Якоби 0-5 порядков;  $\gamma = 2$ ,  $c = 2$ ,  $\alpha = 2$ ,  $\beta = 0$

$$[1.109] \int \tau^3 P_k^{(2,0)}(\tau, \gamma) d\tau = -\sum_{s=0}^k \binom{k}{s} \binom{k+s+2}{s+2} \times (-1)^s \exp(-(2s+3)\gamma\tau) \left( \frac{\tau^3}{\gamma(2s+3)} + \frac{3\tau^2}{\gamma^2(2s+3)^2} + \frac{6\tau}{\gamma^3(2s+3)^3} + \frac{6}{\gamma^4(2s+3)^4} \right).$$

Частные случаи для неопределенного интеграла 3-ого рода от функций 0-5 порядков:

$$\int \tau^3 P_0^{(2,0)}(\tau, \gamma) d\tau = -\frac{1}{27\gamma^4} \exp(-3\gamma\tau)(9\gamma^3\tau^3 + 9\gamma^2\tau^2 + 6 \times \gamma\tau + 2);$$

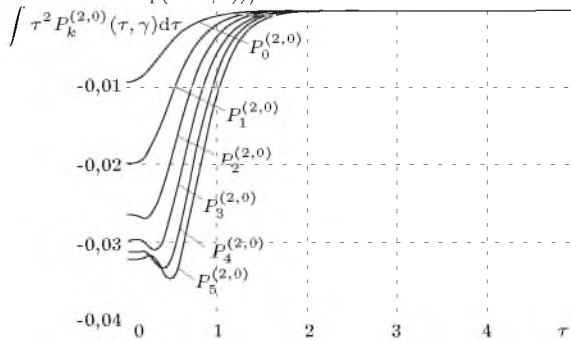
$$\int \tau^3 P_1^{(2,0)}(\tau, \gamma) d\tau = -\frac{1}{5625\gamma^4} \exp(-3\gamma\tau)(1250 - 216 \times \exp(-2\gamma\tau) + \gamma\tau(3750 - 1080 \exp(-2\gamma\tau) + \gamma^2\tau^2(5625 - 2700 \times \exp(-2\gamma\tau)) + \gamma^3\tau^3(5625 - 4500 \exp(-2\gamma\tau)));$$

$$\int \tau^3 P_2^{(2,0)}(\tau, \gamma) d\tau = -\frac{1}{2701125\gamma^4} \exp(-3\gamma\tau)(1200500 - 518616 \exp(-2\gamma\tau) + 101250 \exp(-4\gamma\tau) + \gamma\tau(3601500 - 2593080 \exp(-2\gamma\tau) + 708750 \exp(-4\gamma\tau)) + \gamma^2\tau^2(5402250 - 6482700 \exp(-2\gamma\tau) + 2480625 \exp(-4\gamma\tau)) + \gamma^3\tau^3(5402250 - 10804500 \exp(-2\gamma\tau) + 5788125 \exp(-4\gamma\tau)));$$

$$\int \tau^3 P_3^{(2,0)}(\tau, \gamma) d\tau = -\frac{1}{93767625\gamma^4} \exp(-3\gamma\tau)(69457500 - 54010152 \exp(-2\gamma\tau) + 24603750 \exp(-4\gamma\tau) - 4802000 \times \exp(-6\gamma\tau) + \gamma\tau(208372500 - 270050760 \exp(-2\gamma\tau) + 172226250 \exp(-4\gamma\tau) - 43218000 \exp(-6\gamma\tau)) + \gamma^2\tau^2(312558750 - 675126900 \exp(-2\gamma\tau) + 602791875 \times \exp(-4\gamma\tau) - 194481000 \exp(-6\gamma\tau)) + \gamma^3\tau^3(312558750 - 1125211500 \exp(-2\gamma\tau) + 1406514375 \exp(-4\gamma\tau) - 583443000 \exp(-6\gamma\tau)));$$

$$\int \tau^3 P_4^{(2,0)}(\tau, \gamma) d\tau = -\frac{1}{152539088625\gamma^4} \exp(-3\gamma\tau) \times (169487876250 - 205012535112 \exp(-2\gamma\tau) + 160099335000 \times \exp(-4\gamma\tau) - 70306082000 \exp(-6\gamma\tau) + 13127467500 \times \exp(-8\gamma\tau) + \gamma\tau(508463628750 - 1025062675560 \exp(-2\gamma\tau) + 1120695345000 \exp(-4\gamma\tau) - 632754738000 \exp(-6\gamma\tau) + 144402142500 \exp(-8\gamma\tau)) + \gamma^2\tau^2(762695443125 - 2562656688900 \exp(-2\gamma\tau) + 3922433707500 \exp(-4\gamma\tau) - 2847396321000 \exp(-6\gamma\tau) + 794211783750 \exp(-8\gamma\tau)) + \gamma^3\tau^3(762695443125 - 4271094481500 \exp(-2\gamma\tau) + 9152345317500 \exp(-4\gamma\tau) - 8542188963000 \exp(-6\gamma\tau) + 2912109873750 \exp(-8\gamma\tau)));$$

$$\int \tau^3 P_5^{(2,0)}(\tau, \gamma) d\tau = -\frac{1}{396060810019875\gamma^4} \exp(-3\gamma\tau) \times (616094593364250 - 1064611457333424 \exp(-2\gamma\tau) + 1247071938255000 \exp(-4\gamma\tau) - 912732730910000 \times \exp(-6\gamma\tau) + 374933599267500 \exp(-8\gamma\tau) - 65896886286000 \exp(-10\gamma\tau) + \gamma\tau(1848283780092750 - 5323057286667120 \exp(-2\gamma\tau) + 8729503567785000 \times \exp(-4\gamma\tau) - 82145945781900000 \exp(-6\gamma\tau) + 4124269591942500 \exp(-8\gamma\tau) - 856659521718000 \times \exp(-10\gamma\tau)) + \gamma^2\tau^2(2772425670139125 - 13307643216667800 \exp(-2\gamma\tau) + 30553262487247500 \times \exp(-4\gamma\tau) - 36965675601855000 \exp(-6\gamma\tau) + 22683482755683750 \exp(-8\gamma\tau) - 5568286891167000 \times \exp(-10\gamma\tau)) + \gamma^3\tau^3(2772425670139125 - 22179405361113000 \exp(-2\gamma\tau) + 71290945803577500 \times \exp(-4\gamma\tau) - 110897026805565000 \exp(-6\gamma\tau) +$$

$$+ 83172770104173750 \exp(-8\gamma\tau) - 24129243195057000 \times \exp(-10\gamma\tau)).$$



Рис. 1.109. Вид неопределенного интеграла 3-ого рода от ортогональных функций Якоби 0-5 порядков;  $\gamma = 2, c = 2, \alpha = 2, \beta = 0$

$$[1.110] \int \tau^n P_k^{(2,0)}(\tau, \gamma) d\tau = - \sum_{s=0}^k \binom{k}{s} \binom{k+s+2}{s+2} \times (-1)^s \exp(-(2s+3)\gamma\tau) \sum_{j=0}^n \frac{n! \tau^{n-j}}{(n-j)! (\gamma(2s+3))^{j+1}}.$$

Частные случаи для неопределенного интеграла n-ого рода от функций 0-5 порядков:

$$\int \tau^n P_0^{(2,0)}(\tau, \gamma) d\tau = - \frac{2n!}{\gamma} \exp(-\gamma\tau) \sum_{j=0}^n \left(\frac{2}{3\gamma}\right)^j \frac{\tau^{n-j}}{(n-j)!};$$

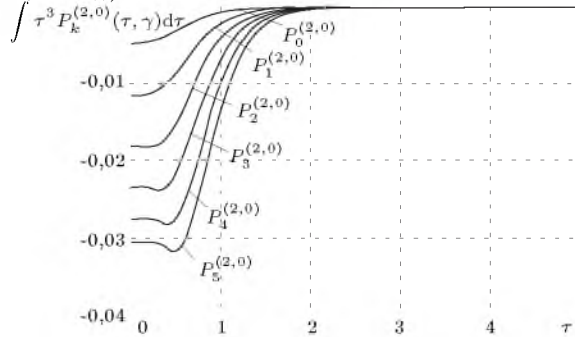
$$\int \tau^n P_1^{(2,0)}(\tau, \gamma) d\tau = - \exp(-3\gamma\tau) \times$$

$$\times \left( 3n! \sum_{j=0}^n \frac{\tau^{n-j}}{(n-j)! (3\gamma)^{j+1}} - n! \exp(-2\gamma\tau) \sum_{j=0}^n \frac{\tau^{n-j}}{(n-j)! (5\gamma)^{j+1}} \right);$$

$$\int \tau^n P_2^{(2,0)}(\tau, \gamma) d\tau = - \exp(-3\gamma\tau) \times$$

$$\times \left( 6n! \sum_{j=0}^n \frac{\tau^{n-j}}{(n-j)! (3\gamma)^{j+1}} - 20n! \exp(-2\gamma\tau) \sum_{j=0}^n \frac{\tau^{n-j}}{(n-j)! (5\gamma)^{j+1}} + 15n! \exp(-4\gamma\tau) \sum_{j=0}^n \frac{\tau^{n-j}}{(n-j)! (7\gamma)^{j+1}} \right);$$

$$\int \tau^n P_3^{(2,0)}(\tau, \gamma) d\tau = - \exp(-3\gamma\tau) \times$$

$$\times \left( 10n! \sum_{j=0}^n \frac{\tau^{n-j}}{(n-j)! (3\gamma)^{j+1}} - 60n! \exp(-2\gamma\tau) \sum_{j=0}^n \frac{\tau^{n-j}}{(n-j)! (5\gamma)^{j+1}} + 105n! \exp(-4\gamma\tau) \sum_{j=0}^n \frac{\tau^{n-j}}{(n-j)! (7\gamma)^{j+1}} - \right.$$

$$\left. - 56n! \exp(-6\gamma\tau) \sum_{j=0}^n \frac{\tau^{n-j}}{(n-j)! (9\gamma)^{j+1}} \right);$$

$$\int \tau^n P_4^{(2,0)}(\tau, \gamma) d\tau = - \exp(-3\gamma\tau) \times$$

$$\times \left( 15n! \sum_{j=0}^n \frac{\tau^{n-j}}{(n-j)! (3\gamma)^{j+1}} - 140n! \exp(-2\gamma\tau) \sum_{j=0}^n \frac{\tau^{n-j}}{(n-j)! (5\gamma)^{j+1}} + 420n! \exp(-4\gamma\tau) \sum_{j=0}^n \frac{\tau^{n-j}}{(n-j)! (7\gamma)^{j+1}} - \right.$$

$$\left. - 504n! \exp(-6\gamma\tau) \sum_{j=0}^n \frac{\tau^{n-j}}{(n-j)! (9\gamma)^{j+1}} + 210n! \exp(-8\gamma\tau) \sum_{j=0}^n \frac{\tau^{n-j}}{(n-j)! (11\gamma)^{j+1}} \right);$$

$$\int \tau^n P_5^{(2,0)}(\tau, \gamma) d\tau = - \exp(-3\gamma\tau) \times$$

$$\times \left( 21n! \sum_{j=0}^n \frac{\tau^{n-j}}{(n-j)! (3\gamma)^{j+1}} - 280n! \exp(-2\gamma\tau) \sum_{j=0}^n \frac{\tau^{n-j}}{(n-j)! (5\gamma)^{j+1}} + 1260n! \exp(-4\gamma\tau) \sum_{j=0}^n \frac{\tau^{n-j}}{(n-j)! (7\gamma)^{j+1}} - \right.$$

$$\left. - 2520n! \exp(-6\gamma\tau) \sum_{j=0}^n \frac{\tau^{n-j}}{(n-j)! (9\gamma)^{j+1}} + 2310n! \exp(-8\gamma\tau) \sum_{j=0}^n \frac{\tau^{n-j}}{(n-j)! (11\gamma)^{j+1}} - \right.$$

$$\left. - 792n! \exp(-10\gamma\tau) \sum_{j=0}^n \frac{\tau^{n-j}}{(n-j)! (13\gamma)^{j+1}} \right).$$

$$\int \tau^n P_k^{(2,0)}(\tau, \gamma) d\tau$$



Рис. 1.110. Вид неопределенного интеграла n-ого рода от ортогональных функций Якоби 2-ого порядка;  $n = 0.5, \gamma = 2, c = 2, \alpha = 2, \beta = 0$

$$[1.111] \quad \int P_k^{(\alpha,0)}(\tau, \gamma) d\tau = - \sum_{s=0}^k \binom{k}{s} \binom{k+s+\alpha}{s+\alpha} \times \\ \times \frac{2(-1)^s}{c\gamma(2s+\alpha+1)} \exp(-(2s+\alpha+1)c\gamma\tau/2).$$

Частные случаи для неопределенного интеграла от функций 0-5 порядков:

$$\int P_0^{(\alpha,0)}(\tau, \gamma) d\tau = - \frac{2}{c\gamma(\alpha+1)} \exp(-c\gamma\tau(\alpha+1)/2); \\ \int P_1^{(\alpha,0)}(\tau, \gamma) d\tau = - \frac{2}{c\gamma(\alpha+3)} \exp(-c\gamma\tau(\alpha+1)/2) (\alpha+3 - \\ - (\alpha+2) \exp(-c\gamma\tau)); \\ \int P_2^{(\alpha,0)}(\tau, \gamma) d\tau = - \frac{1}{c\gamma(\alpha+5)} \exp(-c\gamma\tau(\alpha+1)/2) (\alpha^2+7\alpha+ \\ + 10 - 2(\alpha^2+7\alpha+10) \exp(-c\gamma\tau) + (\alpha^2+7\alpha+12) \exp(-2c\gamma\tau)); \\ \int P_3^{(\alpha,0)}(\tau, \gamma) d\tau = - \frac{1}{3c\gamma(\alpha+7)} \exp(-c\gamma\tau(\alpha+1)/2) (\alpha^3+ \\ + 12\alpha^2+41\alpha+42 - (3\alpha^3+39\alpha^2+150\alpha+168) \exp(-c\gamma\tau) +$$

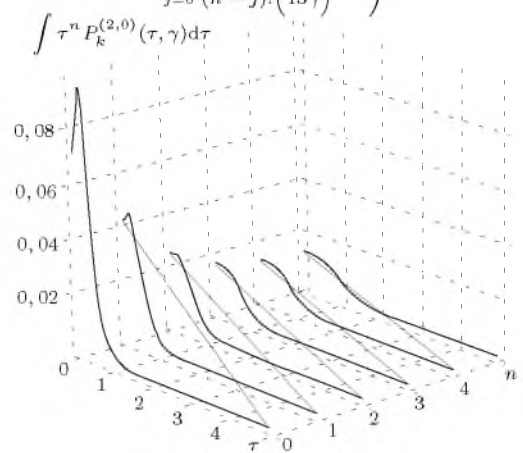
$$+ (3\alpha^3+42\alpha^2+183\alpha+252) \exp(-2c\gamma\tau) - (\alpha^3+15\alpha^2+74\alpha+ \\ + 120) \exp(-3c\gamma\tau));$$

$$\int P_4^{(\alpha,0)}(\tau, \gamma) d\tau = - \frac{1}{12c\gamma(\alpha+9)} \exp(-c\gamma\tau(\alpha+1)/2) (\alpha^4+ \\ + 18\alpha^3+107\alpha^2+258\alpha+216 - (4\alpha^4+80\alpha^3+548\alpha^2+ \\ + 1528\alpha+1440) \exp(-c\gamma\tau) + (6\alpha^4+132\alpha^3+1026\alpha^2+ \\ + 3348\alpha+3888) \exp(-2c\gamma\tau) - (4\alpha^4+96\alpha^3+836\alpha^2+3144\alpha+ \\ + 4320) \exp(-3c\gamma\tau) + (\alpha^4+26\alpha^3+251\alpha^2+1066\alpha+1680) \times \\ \times \exp(-4c\gamma\tau));$$

$$\int P_5^{(\alpha,0)}(\tau, \gamma) d\tau = - \frac{1}{60c\gamma(\alpha+11)} \exp(-c\gamma\tau(\alpha+1)/2) (\alpha^5+ \\ + 25\alpha^4+225\alpha^3+935\alpha^2+1814\alpha+1320 - (5\alpha^5+140\alpha^4+1455\alpha^3+ \\ + 7060\alpha^2+15940\alpha+13200) \exp(-c\gamma\tau) + (10\alpha^5+310\alpha^4+ \\ + 3650\alpha^3+20450\alpha^2+54540\alpha+55440) \exp(-2c\gamma\tau) - \\ - (10\alpha^5+340\alpha^4+4470\alpha^3+28460\alpha^2+87920\alpha+105600) \times \\ \times \exp(-3c\gamma\tau) + (5\alpha^5+185\alpha^4+2685\alpha^3+19135\alpha^2+67030\alpha+ \\ + 92400) \exp(-4c\gamma\tau) - (\alpha^5+40\alpha^4+635\alpha^3+5000\alpha^2+19524\alpha+ \\ + 30240) \exp(-5c\gamma\tau)).$$



Рис. 1.111. Вид неопределенного интеграла от ортогональных функций Якоби 2-ого порядка: а)  $\gamma = 2$ ,  $\alpha \in [0; 5]$ ; б)  $\gamma \in \{1; 3; 5\}$ ,  $\alpha = 1$

$$[1.112] \quad \int \tau P_k^{(\alpha,0)}(\tau, \gamma) d\tau = - \sum_{s=0}^k \binom{k}{s} \binom{k+s+\alpha}{s+\alpha} \times \\ \times (-1)^s \exp(-(2s+\alpha+1)c\gamma\tau/2) \times \\ \times \left( \frac{2\tau}{c\gamma(2s+\alpha+1)} + \frac{4}{c^2\gamma^2(2s+\alpha+1)^2} \right).$$

Частные случаи для неопределенного интеграла 1-ого рода от функций 0-5 порядков:

$$\int \tau P_0^{(\alpha,0)}(\tau, \gamma) d\tau = - \frac{2}{c^2\gamma^2(\alpha+1)^2} \exp(-c\gamma\tau(\alpha+1)/2) \times \\ \times (\gamma\tau(\alpha+1)+2); \\ \int \tau P_1^{(\alpha,0)}(\tau, \gamma) d\tau = - \frac{2}{c^2\gamma^2(\alpha+1)(\alpha+3)^2} \times \\ \times \exp(-c\gamma\tau(\alpha+1)/2) (2(\alpha+3)^2 - 2(\alpha^2+3\alpha+2) \exp(-c\gamma\tau) + \\ + \gamma\tau(\alpha^3+7\alpha^2+15\alpha+9 - (\alpha^3+6\alpha^2+11\alpha+6) \exp(-c\gamma\tau)));$$

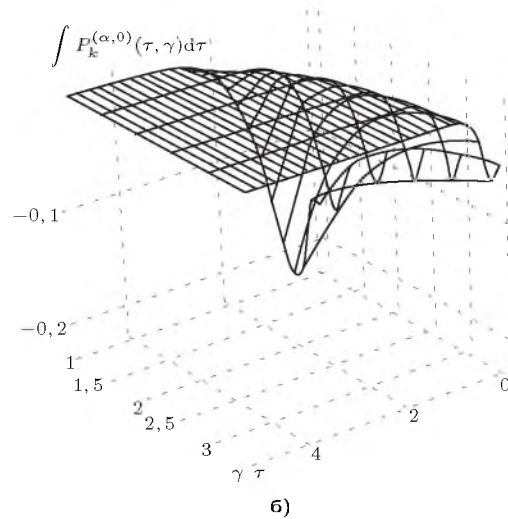
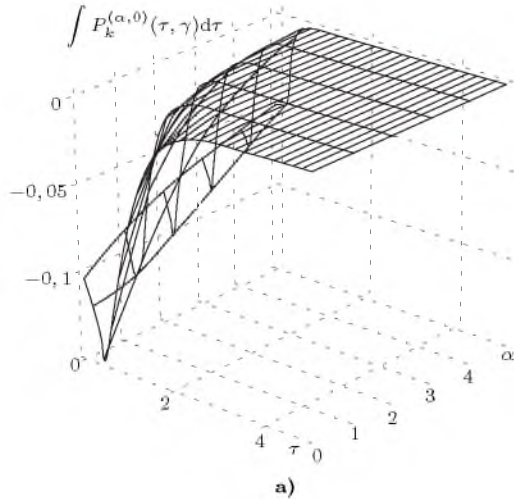
$$\int \tau P_2^{(\alpha,0)}(\tau, \gamma) d\tau = - \frac{1}{c^2\gamma^2(\alpha+1)(\alpha+3)(\alpha+5)^2} \times \\ \times \exp(-c\gamma\tau(\alpha+1)/2) (2\alpha^4+30\alpha^3+162\alpha^2+370\alpha+300 - (4\alpha^4+ \\ + 52\alpha^3+228\alpha^2+380\alpha+200) \exp(-c\gamma\tau) + (2\alpha^4+22\alpha^3+86\alpha^2+ \\ + 138\alpha+72) \exp(-2c\gamma\tau) + \gamma\tau(\alpha^5+16\alpha^4+96\alpha^3+266\alpha^2+335\alpha+ \\ + 150 - (\alpha^5+32\alpha^4+192\alpha^3+532\alpha^2+670\alpha+300) \exp(-c\gamma\tau) + \\ + (\alpha^5+16\alpha^4+98\alpha^3+284\alpha^2+381\alpha+180) \exp(-2c\gamma\tau))); \\ \int \tau P_3(\alpha, 0)(\tau, \gamma) d\tau = - \frac{1}{c^2\gamma^2(\alpha+1)^2(\alpha+3)^2(\alpha+5)^2} \times \\ \times \frac{1}{(\alpha+7)^2} \exp(-c\gamma\tau(\alpha+1)/2) \left( \frac{\alpha+3}{\alpha} (2\alpha^6+60\alpha^5+734\alpha^4+ \\ + 4680\alpha^3+16382\alpha^2+29820\alpha+22050) - \frac{\alpha+4}{\alpha+1} (6\alpha^6+156\alpha^5+ \\ + 1578\alpha^4+7752\alpha^3+18714\alpha^2+19740\alpha+7350) \exp(-c\gamma\tau) + \right. \\ \left. + \frac{\alpha+5}{\alpha+2} (6\alpha^6+132\alpha^5+1098\alpha^4+4344\alpha^3+8538\alpha^2+7812\alpha+ \\ + 2646) \exp(-2c\gamma\tau) - \frac{\alpha+6}{\alpha+3} (2\alpha^6+36\alpha^5+254\alpha^4+888\alpha^3+ \right.$$

$$\begin{aligned}
 & + 1380\alpha^2 + 1380\alpha + 450) \exp(-3c\gamma\tau) + \gamma\tau \left( \binom{\alpha+3}{\alpha} (\alpha^7 + 31 \times \right. \\
 & \times \alpha^6 + 397\alpha^5 + 2707\alpha^4 + 10531\alpha^3 + 23101\alpha^2 + 25935\alpha + 22050) - \\
 & - \binom{\alpha+4}{\alpha+1} (3\alpha^7 + 87\alpha^6 + 1023\alpha^5 + 6243\alpha^4 + 20985\alpha^3 + 37941\alpha^2 + \\
 & + 33285\alpha + 11025) \exp(-c\gamma\tau) + \binom{\alpha+5}{\alpha+2} (3\alpha^7 + 81\alpha^6 + 879\alpha^5 + \\
 & + 4917\alpha^4 + 15129\alpha^3 + 25251\alpha^2 + 20853\alpha + 6615) \exp(-2c\gamma\tau) - \\
 & - \binom{\alpha+6}{\alpha+3} (\alpha^7 + 25\alpha^6 + 253\alpha^5 + 1333\alpha^4 + 3907\alpha^3 + 6283\alpha^2 + \\
 & + 5055\alpha + 1575) \exp(-3c\gamma\tau) \Big); \\
 & \int \tau P_4^{(\alpha,0)}(\tau, \gamma) d\tau = -\frac{2}{c^2\gamma^2(\alpha+1)^2(\alpha+3)^2(\alpha+5)^2} \times \\
 & \times \frac{1}{(\alpha+7)^2(\alpha+9)^2} \exp(-c\gamma\tau(\alpha+1)/2) \left( \binom{\alpha+4}{\alpha} (2\alpha^8 + 96\alpha^7 + \right. \\
 & + 1976\alpha^6 + 22752\alpha^5 + 160076\alpha^4 + 703776\alpha^3 + 1885752\alpha^2 + \\
 & + 2812320\alpha + 1786050) - \binom{\alpha+5}{\alpha+1} (8\alpha^8 + 352\alpha^7 + 6496\alpha^6 + \\
 & + 65056\alpha^5 + 381424\alpha^4 + 1312672\alpha^3 + 2504672\alpha^2 + 2308320\alpha + \\
 & + 793800) \exp(-c\gamma\tau) + \binom{\alpha+6}{\alpha+2} (12\alpha^8 + 480\alpha^7 + 7920\alpha^6 + \\
 & + 69600\alpha^5 + 351336\alpha^4 + 1026720\alpha^3 + 1669680\alpha^2 + 1360800\alpha + \\
 & + 428652) \exp(-2c\gamma\tau) - \binom{\alpha+7}{\alpha+3} (8\alpha^8 + 288\alpha^7 + 4256\alpha^6 + \\
 & + 33504\alpha^5 + 152624\alpha^4 + 408288\alpha^3 + 618912\alpha^2 + 479520\alpha + \\
 & + 145800) \exp(-3c\gamma\tau) + \binom{\alpha+8}{\alpha+4} (2\alpha^8 + 64\alpha^7 + 856\alpha^6 + 6208\alpha^5 + \\
 & + 26476\alpha^4 + 67264\alpha^3 + 98072\alpha^2 + 73920\alpha + 22050) \times \\
 & \times \exp(-4c\gamma\tau) + \gamma\tau \left( \binom{\alpha+4}{\alpha} (\alpha^9 + 49\alpha^8 + 1036\alpha^7 + 12364\alpha^6 + \right. \\
 & + 91414\alpha^5 + 431926\alpha^4 + 1294764\alpha^3 + 2349036\alpha^2 + 2299185\alpha + \\
 & + 893025) - \binom{\alpha+5}{\alpha+1} (4\alpha^9 + 188\alpha^8 + 3776\alpha^7 + 42272\alpha^6 + 288296 \times \\
 & \times \alpha^5 + 1228472\alpha^4 + 3221344\alpha^3 + 4911168\alpha^2 + 23859380\alpha + \\
 & + 1190700) \exp(-c\gamma\tau) + \binom{\alpha+6}{\alpha+2} (6\alpha^9 + 270\alpha^8 + 5160\alpha^7 + \\
 & + 54600\alpha^6 + 349668\alpha^5 + 1391700\alpha^4 + 3401640\alpha^3 + 4854600\alpha^2 + \\
 & + 3616326\alpha + 1071630) \exp(-2c\gamma\tau) - \binom{\alpha+7}{\alpha+3} (4\alpha^9 + 172\alpha^8 + \\
 & + 3136\alpha^7 + 31648\alpha^6 + 193576\alpha^5 + 738328\alpha^4 + 1738464\alpha^3 + \\
 & + 2405952\alpha^2 + 1751220\alpha + 510300) \exp(-3c\gamma\tau) + \binom{\alpha+8}{\alpha+4} (\alpha^9 + \\
 & + 41\alpha^8 + 716\alpha^7 + 6956\alpha^6 + 41174\alpha^5 + 152774\alpha^4 + 351724\alpha^3 + \\
 & + 478284\alpha^2 + 343665\alpha + 99225) \exp(-4c\gamma\tau) \Big); \\
 & \int \tau P_5^{(\alpha,0)}(\tau, \gamma) d\tau = -\frac{2}{c^2\gamma^2(\alpha+1)^2(\alpha+3)^2(\alpha+5)^2} \times
 \end{aligned}$$

$$\begin{aligned}
 & \times \frac{1}{(\alpha+7)^2(\alpha+9)^2(\alpha+11)^2} \exp(-c\gamma\tau(\alpha+1)/2) \left( \binom{\alpha+5}{\alpha} \times \right. \\
 & \times (2\alpha^{10} + 140\alpha^9 + 4330\alpha^8 + 77840\alpha^7 + 6978440\alpha^6 + 6978440\alpha^5 + \\
 & + 36738020\alpha^4 + 129455760\alpha^3 + 291833082\alpha^2 + 379583820\alpha + \\
 & + 216112050) - \binom{\alpha+6}{\alpha+1} (10\alpha^{10} + 660\alpha^9 + 19010\alpha^8 + 313200\alpha^7 + \\
 & + 3248340\alpha^6 + 21969720\alpha^5 + 96919700\alpha^4 + 270305520\alpha^3 + \\
 & + 443302690\alpha^2 + 370962900\alpha + 120062250) \exp(-c\gamma\tau) + \\
 & + \binom{\alpha+7}{\alpha+2} (20\alpha^{10} + 1240\alpha^9 + 33220\alpha^8 + 503200\alpha^7 + \\
 & + 4734760\alpha^6 + 28629520\alpha^5 + 111281960\alpha^4 + 270544800\alpha^3 + \\
 & + 387329220\alpha^2 + 290145240\alpha + 86444820) \exp(-2c\gamma\tau) - \\
 & - \binom{\alpha+8}{\alpha+3} (20\alpha^{10} + 1160\alpha^9 + 28900\alpha^8 + 51852240\alpha^7 + \\
 & + 3511720\alpha^6 + 19550000\alpha^5 + 70171880\alpha^4 + 158746080\alpha^3 + \\
 & + 213958980\alpha^2 + 153073800\alpha + 44104500) \exp(-3c\gamma\tau) + \\
 & + \binom{\alpha+9}{\alpha+4} (10\alpha^{10} + 540\alpha^9 + 12530\alpha^8 + 163920\alpha^7 + 1333140\alpha^6 + \\
 & + 7004520\alpha^5 + 23907380\alpha^4 + 51852240\alpha^3 + 67575010\alpha^2 + \\
 & + 47147100\alpha + 13340250) \exp(-4c\gamma\tau) - \binom{\alpha+10}{\alpha+5} (2\alpha^{10} + 100 \times \\
 & \times \alpha^9 + 2170\alpha^8 + 26800\alpha^7 + 207556\alpha^6 + 1046680\alpha^5 + 3453380\alpha^4 + \\
 & + 7287600\alpha^3 + 9296442\alpha^2 + 6384420\alpha + 1786050) \times \\
 & \times \exp(-5c\gamma\tau) + \gamma\tau \left( \binom{\alpha+5}{\alpha} (\alpha^{11} + 71\alpha^{10} + 2235\alpha^9 + 488778 \times \right. \\
 & \times \alpha^8 + 488778\alpha^7 + 3939078\alpha^6 + 83096890\alpha^5 + 83096890\alpha^4 + \\
 & + 210644421\alpha^3 + 335708451\alpha^2 + 297847935\alpha + 108056025) - \\
 & - \binom{\alpha+6}{\alpha+1} (5\alpha^{11} + 345\alpha^{10} + 10495\alpha^9 + 185115\alpha^8 + 2093970\alpha^7 + \\
 & + 15857370\alpha^6 + 81414430\alpha^5 + 280532310\alpha^4 + 627109625\alpha^3 + \\
 & + 850435485\alpha^2 + 616475475\alpha + 180093375) \exp(-c\gamma\tau) + \\
 & + \binom{\alpha+7}{\alpha+2} (10\alpha^{11} + 670\alpha^{10} + 19710\alpha^9 + 334650\alpha^8 + 3625380\alpha^7 + \\
 & + 26151660\alpha^6 + 127214780\alpha^5 + 413477300\alpha^4 + 870026610\alpha^3 + \\
 & + 1113395670\alpha^2 + 768585510\alpha + 216112050) \exp(-2c\gamma\tau) - \\
 & - \binom{\alpha+8}{\alpha+3} (5\alpha^{11} + 650\alpha^{10} + 18510\alpha^9 + 303630\alpha^8 + 3173220\alpha^7 + \\
 & + 22066020\alpha^6 + 103510940\alpha^5 + 324974620\alpha^4 + 662590770\alpha^3 + \\
 & + 825393330\alpha^2 + 557810550\alpha + 154365750) \exp(-3c\gamma\tau) + \\
 & + \binom{\alpha+9}{\alpha+4} (5\alpha^{11} + 315\alpha^{10} + 8695\alpha^9 + 138345\alpha^8 + 1404210\alpha^7 + \\
 & + 9501390\alpha^6 + 43474030\alpha^5 + 133509330\alpha^4 + 267122585\alpha^3 + \\
 & + 327661095\alpha^2 + 218832075\alpha + 60031125) \exp(-4c\gamma\tau) - \\
 & - \binom{\alpha+10}{\alpha+5} (\alpha^{11} + 61\alpha^{10} + 1635\alpha^9 + 25335\alpha^8 + 251178\alpha^7 + \\
 & + 1664898\alpha^6 + 7483430\alpha^5 + 22637390\alpha^4 + 44730021\alpha^3 + \\
 & + 54322641\alpha^2 + 36007335\alpha + 9823275) \exp(-5c\gamma\tau) \Big).
 \end{aligned}$$



Рис. 1.112. Вид неопределенного интеграла 1-ого рода от ортогональных функций Якоби 2-ого порядка: а)  $\gamma = 2$ ,  $\alpha \in [0; 5]$ ; б)  $\gamma \in \{1; 3; 5\}$ ,  $\alpha = 1$

$$[1.113] \quad \int \tau^2 P_k^{(\alpha,0)}(\tau, \gamma) d\tau = - \sum_{s=0}^k \binom{k}{s} \binom{k+s+\alpha}{s+\alpha} \times \\ \times (-1)^s \exp(-(2s+\alpha+1)c\gamma\tau/2) \left( \frac{2\tau^2}{c\gamma(2s+\alpha+1)} + \right. \\ \left. + \frac{8\tau}{c^2\gamma^2(2s+\alpha+1)^2} + \frac{16}{c^3\gamma^3(2s+\alpha+1)^3} \right).$$

Частные случаи для неопределенного интеграла 2-ого рода от функций 0-5 порядков:

$$\int \tau^2 P_0^{(\alpha,0)}(\tau, \gamma) d\tau = - \frac{2}{c^3\gamma^3(\alpha+1)^3} \exp(-c\gamma\tau(\alpha+1)/2) (8 + \\ + 4c\gamma\tau(\alpha+1) + c^2\gamma^2\tau^2(\alpha+1)^2); \\ \int \tau^2 P_1^{(\alpha,0)}(\tau, \gamma) d\tau = - \frac{2}{c^3\gamma^3(\alpha+1)^2} \exp(-c\gamma\tau(\alpha+1)/2) (8 + \\ + 4c\gamma\tau(\alpha+1) + c^2\gamma^2\tau^2(\alpha+1)^2) + \frac{2}{c^3\gamma^3(\alpha+3)^3} \times \\ \times \exp(-c\gamma\tau(\alpha+3)/2) (\alpha+2)(8+4c\gamma\tau(\alpha+3) + c^2\gamma^2\tau^2(\alpha+3)^2); \\ \int \tau^2 P_2^{(\alpha,0)}(\tau, \gamma) d\tau = - \frac{1}{c^3\gamma^3(\alpha+1)^2} \exp(-c\gamma\tau(\alpha+1)/2) \times \\ \times (\alpha+2)(8+4c\gamma\tau(\alpha+1) + c^2\gamma^2\tau^2(\alpha+1)^2) + \frac{2}{c^3\gamma^3(\alpha+3)^3} \times \\ \times \exp(-c\gamma\tau(\alpha+3)/2) (\alpha+2)(8+4c\gamma\tau(\alpha+3) + c^2\gamma^2\tau^2 \times \\ \times (\alpha+3)^2) - \frac{1}{c^3\gamma^3(\alpha+5)^3} \exp(-c\gamma\tau(\alpha+5)/2) (\alpha^2 + 7\alpha + 12) \times \\ \times (8+4c\gamma\tau(\alpha+5) + c^2\gamma^2\tau^2(\alpha+5)^2); \\ \int \tau^2 P_3^{(\alpha,0)}(\tau, \gamma) d\tau = - \frac{2}{c^3\gamma^3(\alpha+1)^3} \exp(-c\gamma\tau(\alpha+1)/2) \times \\ \times \binom{\alpha+3}{\alpha} (8+4c\gamma\tau(\alpha+1) + c^2\gamma^2\tau^2(\alpha+1)^2) + \frac{6}{c^3\gamma^3(\alpha+3)^3} \times \\ \times \exp(-c\gamma\tau(\alpha+3)/2) \binom{\alpha+4}{\alpha+1} (8+4c\gamma\tau(\alpha+3) + c^2\gamma^2\tau^2 \times \\ \times (\alpha+3)^2) - \frac{6}{c^3\gamma^3(\alpha+5)^3} \exp(-c\gamma\tau(\alpha+5)/2) \binom{\alpha+5}{\alpha+2} \times$$

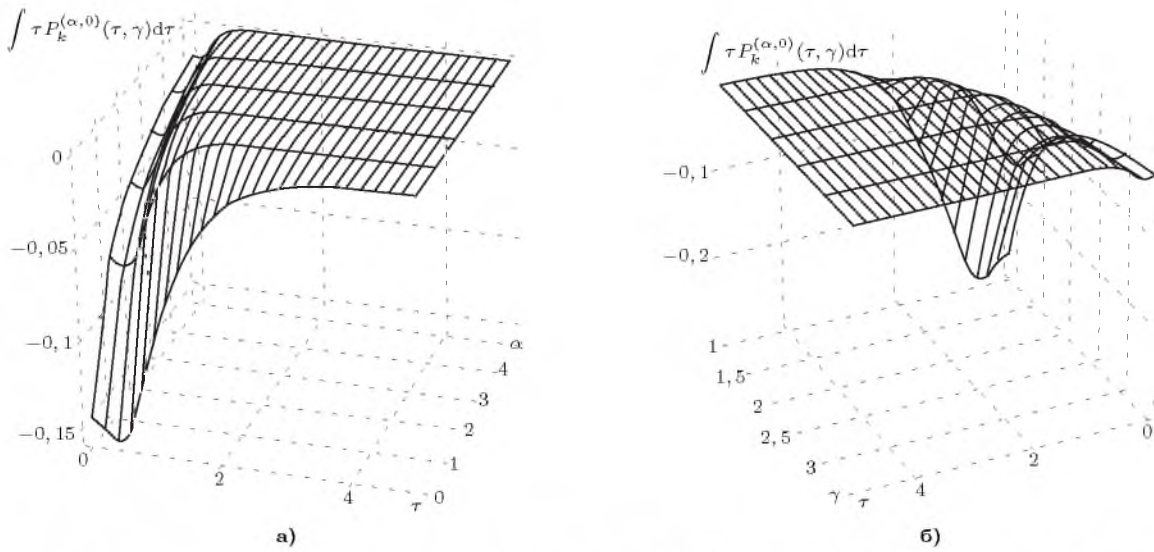
$$\times (8+4c\gamma\tau(\alpha+5) + c^2\gamma^2\tau^2(\alpha+5)^2) + \frac{2}{c^3\gamma^3(\alpha+7)^3} \times \\ \times \exp(-c\gamma\tau(\alpha+7)/2) \binom{\alpha+6}{\alpha+3} (8+4c\gamma\tau(\alpha+7) + c^2\gamma^2\tau^2 \times \\ \times (\alpha+7)^2); \\ \int \tau^2 P_4^{(\alpha,0)}(\tau, \gamma) d\tau = - \frac{2}{c^3\gamma^3(\alpha+1)^3} \exp(-c\gamma\tau(\alpha+1)/2) \times \\ \times \binom{\alpha+4}{\alpha} (8+4c\gamma\tau(\alpha+1) + c^2\gamma^2\tau^2(\alpha+1)^2) + \frac{8}{c^3\gamma^3(\alpha+3)^3} \times \\ \times \exp(-c\gamma\tau(\alpha+3)/2) \binom{\alpha+5}{\alpha+1} (8+4c\gamma\tau(\alpha+3) + c^2\gamma^2\tau^2 \times \\ \times (\alpha+3)^2) - \frac{12}{c^3\gamma^3(\alpha+5)^3} \exp(-c\gamma\tau(\alpha+5)/2) \binom{\alpha+6}{\alpha+2} \times \\ \times (8+4c\gamma\tau(\alpha+5) + c^2\gamma^2\tau^2(\alpha+5)^2) + \frac{8}{c^3\gamma^3(\alpha+7)^3} \times \\ \times \exp(-c\gamma\tau(\alpha+7)/2) \binom{\alpha+7}{\alpha+3} (8+4c\gamma\tau(\alpha+7) + c^2\gamma^2\tau^2 \times \\ \times (\alpha+7)^2) - \frac{2}{c^3\gamma^3(\alpha+9)^3} \exp(-c\gamma\tau(\alpha+9)/2) \binom{\alpha+8}{\alpha+4} \times \\ \times (8+4c\gamma\tau(\alpha+9) + c^2\gamma^2\tau^2(\alpha+9)^2); \\ \int \tau^2 P_5^{(\alpha,0)}(\tau, \gamma) d\tau = - \frac{2}{c^3\gamma^3(\alpha+1)^3} \exp(-c\gamma\tau(\alpha+1)/2) \times \\ \times \binom{\alpha+5}{\alpha} (8+4c\gamma\tau(\alpha+1) + c^2\gamma^2\tau^2(\alpha+1)^2) + \frac{10}{c^3\gamma^3(\alpha+3)^3} \times \\ \times \exp(-c\gamma\tau(\alpha+3)/2) \binom{\alpha+6}{\alpha+1} (8+4c\gamma\tau(\alpha+3) + c^2\gamma^2\tau^2 \times \\ \times (\alpha+3)^2) - \frac{20}{c^3\gamma^3(\alpha+5)^3} \exp(-c\gamma\tau(\alpha+5)/2) \binom{\alpha+7}{\alpha+2} \times \\ \times (8+4c\gamma\tau(\alpha+5) + c^2\gamma^2\tau^2(\alpha+5)^2) + \frac{20}{c^3\gamma^3(\alpha+7)^3} \times \\ \times \exp(-c\gamma\tau(\alpha+7)/2) \binom{\alpha+8}{\alpha+3} (8+4c\gamma\tau(\alpha+7) + c^2\gamma^2\tau^2 \times \\ \times (\alpha+7)^2) - \frac{10}{c^3\gamma^3(\alpha+9)^3} \exp(-c\gamma\tau(\alpha+9)/2) \binom{\alpha+9}{\alpha+4} \times \\ \times (8+4c\gamma\tau(\alpha+9) + c^2\gamma^2\tau^2(\alpha+9)^2) + \frac{2}{c^3\gamma^3(\alpha+11)^3} \times \\ \times \exp(-c\gamma\tau(\alpha+11)/2) \binom{\alpha+10}{\alpha+5} (8+4c\gamma\tau(\alpha+11) + c^2\gamma^2\tau^2 \times \\ \times (\alpha+11)^2).$$



Рис. 1.113. Вид неопределенного интеграла 2-ого рода от ортогональных функций Якоби 2-ого порядка: а)  $\gamma = 2$ ,  $\alpha \in [0; 5]$ ; б)  $\gamma \in \{1; 3, 5\}$ ,  $\alpha = 1$

$$[1.114] \quad \int \tau^3 P_k^{(\alpha,0)}(\tau, \gamma) d\tau = - \sum_{s=0}^k \binom{k}{s} \binom{k+s+\alpha}{s+\alpha} \times (-1)^s \exp(-2s+\alpha+1)c\gamma\tau/2) \times \left( \frac{2\tau^3}{c\gamma(2s+\alpha+1)} + \frac{12\tau^2}{c^2\gamma^2(2s+\alpha+1)^2} + \frac{48\tau}{c^3\gamma^3(2s+\alpha+1)^3} + \frac{96}{c^4\gamma^4(2s+\alpha+1)^4} \right).$$

Частные случаи для неопределенного интеграла 3-ого рода от функций 0-5 порядков:

$$\begin{aligned} \int \tau^3 P_0^{(\alpha,0)}(\tau, \gamma) d\tau &= - \frac{2}{c^4\gamma^4(\alpha+1)^4} \exp(-c\gamma\tau(\alpha+1)/2) \times \\ &\times (48+24c\gamma\tau(\alpha+1)+6c^2\gamma^2\tau^2(\alpha+1)^2+c^3\gamma^3\tau^3(\alpha+1)^3); \\ \int \tau^3 P_1^{(\alpha,0)}(\tau, \gamma) d\tau &= - \frac{2}{c^4\gamma^4(\alpha+1)^3} \exp(-c\gamma\tau(\alpha+1)/2) \times \\ &\times (48+24c\gamma\tau(\alpha+1)+6c^2\gamma^2\tau^2(\alpha+1)^2+c^3\gamma^3\tau^3(\alpha+1)^3) + \\ &+ \frac{2}{c^4\gamma^4(\alpha+3)^4} \exp(-c\gamma\tau(\alpha+3)/2) (\alpha+2)(48+24c\gamma\tau(\alpha+3) + \\ &+ 6c^2\gamma^2\tau^2(\alpha+3)^2+c^3\gamma^3\tau^3(\alpha+3)^3); \\ \int \tau^3 P_2^{(\alpha,0)}(\tau, \gamma) d\tau &= - \frac{2}{c^4\gamma^4(\alpha+1)^4} \exp(-c\gamma\tau(\alpha+1)/2) \times \\ &\times \binom{\alpha+2}{\alpha} (48+24c\gamma\tau(\alpha+1)+6c^2\gamma^2\tau^2(\alpha+1)^2+c^3\gamma^3\tau^3 \times \\ &\times (\alpha+1)^3) + \frac{4}{c^4\gamma^4(\alpha+3)^4} \exp(-c\gamma\tau(\alpha+3)/2) \binom{\alpha+3}{\alpha+1} \times \\ &\times (48+24c\gamma\tau(\alpha+3)+6c^2\gamma^2\tau^2(\alpha+3)^2+c^3\gamma^3\tau^3(\alpha+3)^3) - \\ &- \frac{2}{c^4\gamma^4(\alpha+5)^4} \exp(-c\gamma\tau(\alpha+5)/2) \binom{\alpha+4}{\alpha+2} (48+24c\gamma\tau \times \\ &\times (\alpha+5)+6c^2\gamma^2\tau^2(\alpha+5)^2+c^3\gamma^3\tau^3(\alpha+5)^3); \\ \int \tau^3 P_3^{(\alpha,0)}(\tau, \gamma) d\tau &= - \frac{2}{c^4\gamma^4(\alpha+1)^4} \exp(-c\gamma\tau(\alpha+1)/2) \times \\ &\times \binom{\alpha+3}{\alpha} (48+24c\gamma\tau(\alpha+1)+6c^2\gamma^2\tau^2(\alpha+1)^2+c^3\gamma^3\tau^3 \times \\ &\times (\alpha+1)^3) + \frac{6}{c^4\gamma^4(\alpha+3)^4} \exp(-c\gamma\tau(\alpha+3)/2) \binom{\alpha+4}{\alpha+1} \times \\ &\times (48+24c\gamma\tau(\alpha+3)+6c^2\gamma^2\tau^2(\alpha+3)^2+c^3\gamma^3\tau^3(\alpha+3)^3) - \end{aligned}$$

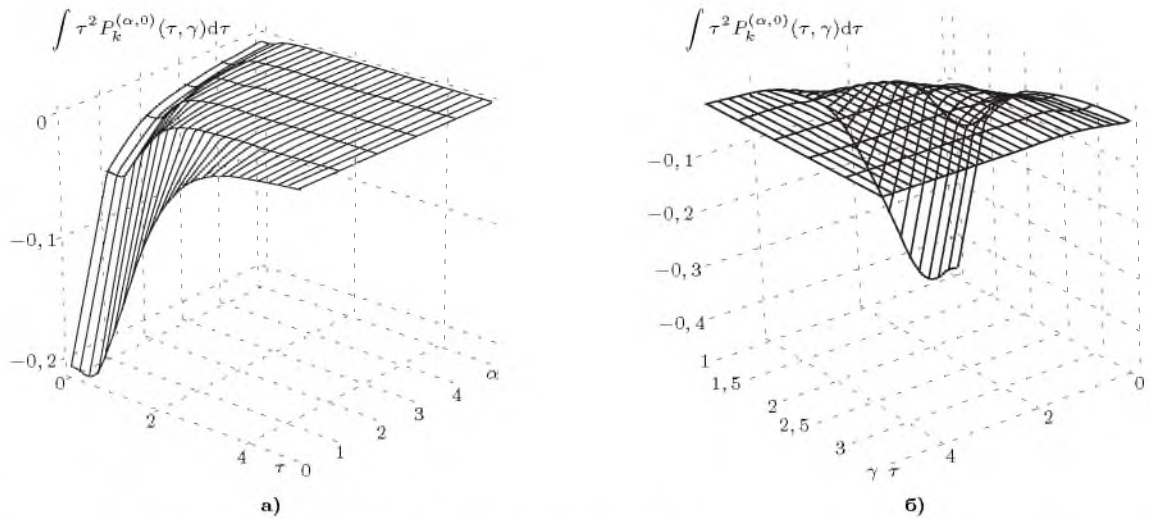
$$\begin{aligned} &- \frac{6}{c^4\gamma^4(\alpha+5)^4} \exp(-c\gamma\tau(\alpha+5)/2) \binom{\alpha+5}{\alpha+2} (48+24c\gamma\tau \times \\ &\times (\alpha+5)+6c^2\gamma^2\tau^2(\alpha+5)^2+c^3\gamma^3\tau^3(\alpha+5)^3) + \\ &+ \frac{2}{c^4\gamma^4(\alpha+7)^4} \exp(-c\gamma\tau(\alpha+7)/2) \binom{\alpha+6}{\alpha+3} (48+24c\gamma\tau \times \\ &\times (\alpha+7)+6c^2\gamma^2\tau^2(\alpha+7)^2+c^3\gamma^3\tau^3(\alpha+7)^3); \\ \int \tau^3 P_4^{(\alpha,0)}(\tau, \gamma) d\tau &= - \frac{2}{c^4\gamma^4(\alpha+1)^4} \exp(-c\gamma\tau(\alpha+1)/2) \times \\ &\times \binom{\alpha+4}{\alpha} (48+24c\gamma\tau(\alpha+1)+6c^2\gamma^2\tau^2(\alpha+1)^2+c^3\gamma^3\tau^3 \times \\ &\times (\alpha+1)^3) + \frac{8}{c^4\gamma^4(\alpha+3)^4} \exp(-c\gamma\tau(\alpha+3)/2) \binom{\alpha+5}{\alpha+1} \times \\ &\times (48+24c\gamma\tau(\alpha+3)+6c^2\gamma^2\tau^2(\alpha+3)^2+c^3\gamma^3\tau^3(\alpha+3)^3) - \\ &- \frac{12}{c^4\gamma^4(\alpha+5)^4} \exp(-c\gamma\tau(\alpha+5)/2) \binom{\alpha+6}{\alpha+2} (48+24c\gamma\tau \times \\ &\times (\alpha+5)+6c^2\gamma^2\tau^2(\alpha+5)^2+c^3\gamma^3\tau^3(\alpha+5)^3) + \\ &+ \frac{8}{c^4\gamma^4(\alpha+7)^4} \exp(-c\gamma\tau(\alpha+7)/2) \binom{\alpha+7}{\alpha+3} (48+24c\gamma\tau \times \\ &\times (\alpha+7)+6c^2\gamma^2\tau^2(\alpha+7)^2+c^3\gamma^3\tau^3(\alpha+7)^3) - \\ &- \frac{2}{c^4\gamma^4(\alpha+9)^4} \exp(-c\gamma\tau(\alpha+9)/2) \binom{\alpha+8}{\alpha+4} (48+24c\gamma\tau \times \\ &\times (\alpha+9)+6c^2\gamma^2\tau^2(\alpha+9)^2+c^3\gamma^3\tau^3(\alpha+9)^3); \\ \int \tau^3 P_5^{(\alpha,0)}(\tau, \gamma) d\tau &= - \frac{2}{c^4\gamma^4(\alpha+1)^4} \exp(-c\gamma\tau(\alpha+1)/2) \times \\ &\times \binom{\alpha+5}{\alpha} (48+24c\gamma\tau(\alpha+1)+6c^2\gamma^2\tau^2(\alpha+1)^2+c^3\gamma^3\tau^3 \times \\ &\times (\alpha+1)^3) + \frac{10}{c^4\gamma^4(\alpha+3)^4} \exp(-c\gamma\tau(\alpha+3)/2) \binom{\alpha+6}{\alpha+1} \times \\ &\times (48+24c\gamma\tau(\alpha+3)+6c^2\gamma^2\tau^2(\alpha+3)^2+c^3\gamma^3\tau^3(\alpha+3)^3) - \\ &- \frac{20}{c^3\gamma^3(\alpha+5)^3} \exp(-c\gamma\tau(\alpha+5)/2) \binom{\alpha+7}{\alpha+2} (48+24c\gamma\tau \times \\ &\times (\alpha+5)+6c^2\gamma^2\tau^2(\alpha+5)^2+c^3\gamma^3\tau^3(\alpha+5)^3) + \\ &+ \frac{20}{c^4\gamma^4(\alpha+7)^4} \exp(-c\gamma\tau(\alpha+7)/2) \binom{\alpha+8}{\alpha+3} (48+24c\gamma\tau \times \\ &\times (\alpha+7)+6c^2\gamma^2\tau^2(\alpha+7)^2+c^3\gamma^3\tau^3(\alpha+7)^3) - \\ &- \frac{10}{c^4\gamma^4(\alpha+9)^4} \exp(-c\gamma\tau(\alpha+9)/2) \binom{\alpha+9}{\alpha+4} (48+24c\gamma\tau \times \\ &\times (\alpha+9)+6c^2\gamma^2\tau^2(\alpha+9)^2+c^3\gamma^3\tau^3(\alpha+9)^3) + \\ &+ \frac{2}{c^4\gamma^4(\alpha+11)^4} \exp(-c\gamma\tau(\alpha+11)/2) \binom{\alpha+10}{\alpha+5} (48+24c\gamma\tau \times \\ &\times (\alpha+11)+6c^2\gamma^2\tau^2(\alpha+11)^2+c^3\gamma^3\tau^3(\alpha+11)^3). \end{aligned}$$



Рис. 1.114. Вид неопределенного интеграла 3-го рода от ортогональных функций Якоби 2-го порядка: а)  $\gamma = 2$ ,  $\alpha \in [0; 5]$ ; б)  $\gamma \in (1; 3, 5]$ ,  $\alpha = 1$

$$[1.115] \quad \int \tau^n P_k^{(\alpha,0)}(\tau, \gamma) d\tau = - \sum_{s=0}^k \binom{k}{s} \binom{k+s+\alpha}{s+\alpha} \times \\ \times (-1)^s \exp(-2s + \alpha + 1)c\gamma\tau/2) \times \\ \times \sum_{j=0}^n \frac{n! \tau^{n-j}}{(n-j)! (c\gamma(2s + \alpha + 1)/2)^{j+1}}.$$

Частные случаи для неопределенного интеграла n-го рода от функций 0-5 порядков:

$$\int \tau^n P_0^{(\alpha,0)}(\tau, \gamma) d\tau = - \frac{2n!}{\gamma} \exp(-c\gamma\tau(\alpha + 1)/2) \times \\ \times \sum_{j=0}^n \left( \frac{2}{c\gamma(\alpha + 1)/2} \right)^j \frac{\tau^{n-j}}{(n-j)!}; \\ \int \tau^n P_1^{(\alpha,0)}(\tau, \gamma) d\tau = - \exp(-c\gamma\tau(\alpha + 1)/2) \times \\ \times \left( (\alpha + 1)n! \sum_{j=0}^n \frac{\tau^{n-j}}{(n-j)! (c\gamma(\alpha + 1)/2)^{j+1}} - \right. \\ \left. - (\alpha + 2)n! \exp(-\gamma\tau) \sum_{j=0}^n \frac{\tau^{n-j}}{(n-j)! (c\gamma(\alpha + 3)/2)^{j+1}} \right); \\ \int \tau^n P_2^{(\alpha,0)}(\tau, \gamma) d\tau = - \exp(-c\gamma\tau(\alpha + 1)/2) \times \\ \times \left( \left( \frac{\alpha + 2}{\alpha} \right) n! \sum_{j=0}^n \frac{\tau^{n-j}}{(n-j)! (c\gamma(\alpha + 1)/2)^{j+1}} - \right. \\ \left. - 2 \left( \frac{\alpha + 3}{\alpha + 1} \right) n! \exp(-c\gamma\tau) \sum_{j=0}^n \frac{\tau^{n-j}}{(n-j)! (c\gamma(\alpha + 3)/2)^{j+1}} + \right. \\ \left. + \left( \frac{\alpha + 4}{\alpha + 2} \right) n! \exp(-2c\gamma\tau) \sum_{j=0}^n \frac{\tau^{n-j}}{(n-j)! (c\gamma(\alpha + 5)/2)^{j+1}} \right); \\ \int \tau^n P_3^{(\alpha,0)}(\tau, \gamma) d\tau = - \exp(-c\gamma\tau(\alpha + 1)/2) \times$$

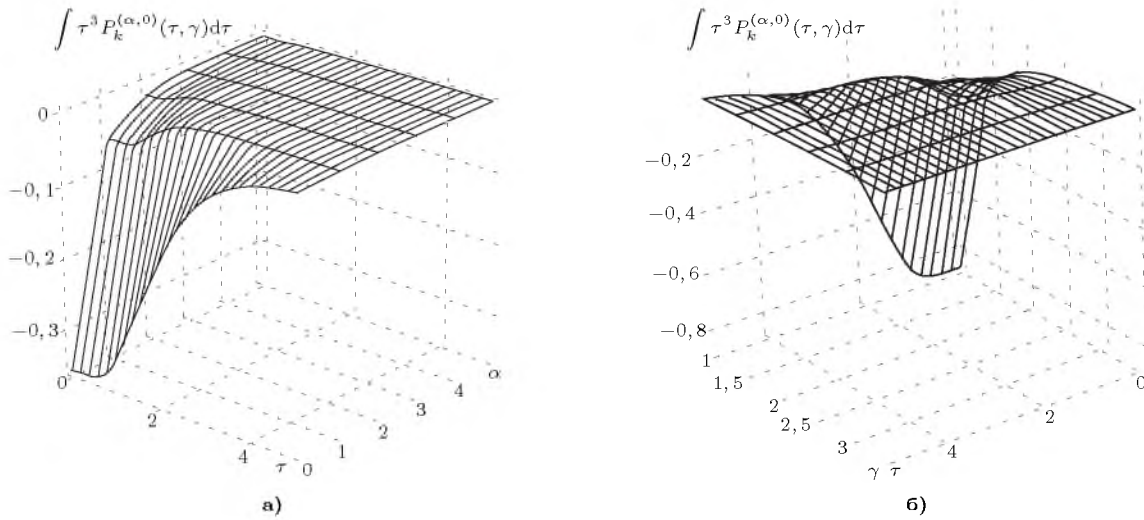
$$\times \left( \left( \frac{\alpha + 3}{\alpha} \right) n! \sum_{j=0}^n \frac{\tau^{n-j}}{(n-j)! (c\gamma(\alpha + 1)/2)^{j+1}} - \right. \\ \left. - 3 \left( \frac{\alpha + 4}{\alpha + 1} \right) n! \exp(-c\gamma\tau) \sum_{j=0}^n \frac{\tau^{n-j}}{(n-j)! (c\gamma(\alpha + 3)/2)^{j+1}} + \right. \\ \left. + 3 \left( \frac{\alpha + 5}{\alpha + 2} \right) n! \exp(-2c\gamma\tau) \sum_{j=0}^n \frac{\tau^{n-j}}{(n-j)! (c\gamma(\alpha + 5)/2)^{j+1}} - \right. \\ \left. - \left( \frac{\alpha + 6}{\alpha + 3} \right) n! \exp(-3c\gamma\tau) \sum_{j=0}^n \frac{\tau^{n-j}}{(n-j)! (9c\gamma(\alpha + 7)/2)^{j+1}} \right); \\ \int \tau^n P_4^{(\alpha,0)}(\tau, \gamma) d\tau = - \exp(-c\gamma\tau(\alpha + 1)/2) \times \\ \times \left( \left( \frac{\alpha + 4}{\alpha} \right) n! \sum_{j=0}^n \frac{\tau^{n-j}}{(n-j)! (c\gamma(\alpha + 1)/2)^{j+1}} - \right. \\ \left. - 4 \left( \frac{\alpha + 5}{\alpha + 1} \right) n! \exp(-c\gamma\tau) \sum_{j=0}^n \frac{\tau^{n-j}}{(n-j)! (c\gamma(\alpha + 3)/2)^{j+1}} + \right. \\ \left. + 6 \left( \frac{\alpha + 6}{\alpha + 2} \right) n! \exp(-2c\gamma\tau) \sum_{j=0}^n \frac{\tau^{n-j}}{(n-j)! (c\gamma(\alpha + 5)/2)^{j+1}} - \right. \\ \left. - 4 \left( \frac{\alpha + 7}{\alpha + 3} \right) n! \exp(-3c\gamma\tau) \sum_{j=0}^n \frac{\tau^{n-j}}{(n-j)! (c\gamma(\alpha + 7)/2)^{j+1}} + \right. \\ \left. + \left( \frac{\alpha + 8}{\alpha + 4} \right) n! \exp(-4c\gamma\tau) \sum_{j=0}^n \frac{\tau^{n-j}}{(n-j)! (c\gamma(\alpha + 9)/2)^{j+1}} \right); \\ \int \tau^n P_5^{(\alpha,0)}(\tau, \gamma) d\tau = - \exp(-c\gamma\tau(\alpha + 1)/2) \times \\ \times \left( \left( \frac{\alpha + 5}{\alpha} \right) n! \sum_{j=0}^n \frac{\tau^{n-j}}{(n-j)! (c\gamma(\alpha + 1)/2)^{j+1}} - \right. \\ \left. - 5 \left( \frac{\alpha + 6}{\alpha + 1} \right) n! \exp(-c\gamma\tau) \sum_{j=0}^n \frac{\tau^{n-j}}{(n-j)! (c\gamma(\alpha + 3)/2)^{j+1}} + \right. \\ \left. + 10 \left( \frac{\alpha + 7}{\alpha + 2} \right) n! \exp(-2c\gamma\tau) \sum_{j=0}^n \frac{\tau^{n-j}}{(n-j)! (c\gamma(\alpha + 5)/2)^{j+1}} - \right.$$



$$- 10 \binom{\alpha + 8}{\alpha + 3} n! \exp(-3c\gamma\tau) \sum_{j=0}^n \frac{\tau^{n-j}}{(n-j)! (c\gamma(\alpha + 7)/2)^{j+1}} +$$

$$+ 5 \binom{\alpha + 9}{\alpha + 4} n! \exp(-4c\gamma\tau) \sum_{j=0}^n \frac{\tau^{n-j}}{(n-j)! (c\gamma(\alpha + 9)/2)^{j+1}} -$$

$$- \binom{\alpha + 10}{\alpha + 5} n! \exp(-5c\gamma\tau) \sum_{j=0}^n \frac{\tau^{n-j}}{(n-j)! (c\gamma(\alpha + 11)/2)^{j+1}} \Bigg)$$



Рис. 1.115. Вид неопределенного интеграла n-ого рода от ортогональных функций Якоби 2-ого порядка: а)  $n = 0.5, \gamma = 2, \alpha \in [0; 5]$ ; б)  $n = 0.5, \gamma \in (1; 3, 5), \alpha = 1$

[1.116] 
$$\int P_k^{(0,1)}(\tau, \gamma) d\tau = - \sum_{s=0}^k \binom{k}{s} \binom{k+s+1}{s} \times$$

$$\times \frac{(-1)^s}{\gamma(2s+1)} \exp(-(2s+1)\gamma\tau).$$

Частные случаи для неопределенного интеграла от функций 0-5 порядков:

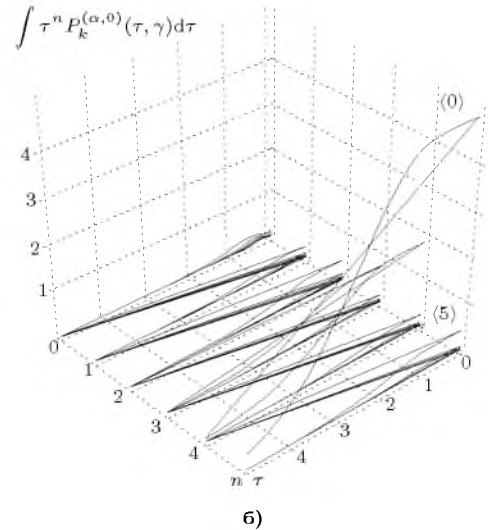
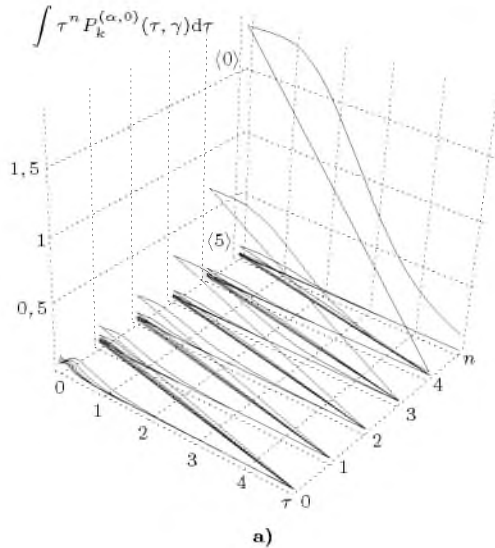
$$\int P_0^{(0,1)}(\tau, \gamma) d\tau = -\frac{1}{\gamma} \exp(-\gamma\tau);$$

$$\int P_1^{(0,1)}(\tau, \gamma) d\tau = -\frac{1}{\gamma} \exp(-\gamma\tau)(1 - \exp(-2\gamma\tau));$$

$$\int P_2^{(0,1)}(\tau, \gamma) d\tau = -\frac{1}{3\gamma} \exp(-\gamma\tau)(3 - 8 \exp(-2\gamma\tau) + 6 \times$$

$$\times \exp(-4\gamma\tau));$$

$$\int P_3^{(0,1)}(\tau, \gamma) d\tau = -\frac{1}{\gamma} \exp(-\gamma\tau)(1 - 5 \exp(-2\gamma\tau) + 9 \times$$

$$\times \exp(-4\gamma\tau) - 5 \exp(-6\gamma\tau));$$

$$\int P_4^{(0,1)}(\tau, \gamma) d\tau = -\frac{1}{5\gamma} \exp(-\gamma\tau)(5 - 40 \exp(-2\gamma\tau) + 126 \times$$

$$\times \exp(-4\gamma\tau) - 160 \exp(-6\gamma\tau) + 70 \exp(-8\gamma\tau));$$

$$\int P_5^{(0,1)}(\tau, \gamma) d\tau = -\frac{1}{3\gamma} \exp(-\gamma\tau)(3 - 35 \exp(-2\gamma\tau) + 168 \times$$

$$\times \exp(-4\gamma\tau) - 360 \exp(-6\gamma\tau) + 350 \exp(-8\gamma\tau) - 126 \times$$

$$\times \exp(-10\gamma\tau)).$$



Рис. 1.116. Вид неопределенного интеграла от ортогональных функций Якоби 0-5 порядков;  $\gamma = 2, c = 2, \alpha = 0, \beta = 1$

[1.117] 
$$\int \tau P_k^{(0,1)}(\tau, \gamma) d\tau = - \sum_{s=0}^k \binom{k}{s} \binom{k+s+1}{s} \times$$

$$\times (-1)^s \exp(-(2s+1)\gamma\tau) \left( \frac{\tau}{\gamma(2s+1)} + \frac{1}{\gamma^2(2s+1)^2} \right).$$

Частные случаи для неопределенного интеграла 1-ого рода от функций 0-5 порядков:

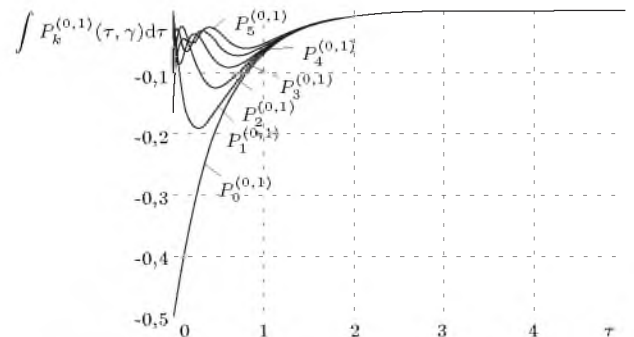
$$\int \tau P_0^{(0,1)}(\tau, \gamma) d\tau = -\frac{1}{\gamma^2} \exp(-\gamma\tau)(\gamma\tau + 1);$$

$$\int \tau P_1^{(0,1)}(\tau, \gamma) d\tau = -\frac{1}{3\gamma^2} \exp(-\gamma\tau)(3 - \exp(-2\gamma\tau) + \gamma\tau \times$$

$$\times (3 - 3 \exp(-2\gamma\tau)));$$



Рис. 1.117. Вид неопределенного интеграла 1-ого рода от ортогональных функций Якоби 0-5 порядков;  $\gamma = 2$ ,  $c = 2$ ,  $\alpha = 0$ ,  $\beta = 1$

$$[1.118] \quad \int \tau^2 P_k^{(0,1)}(\tau, \gamma) d\tau = -\sum_{s=0}^k \binom{k}{s} \binom{k+s+1}{s} \times (-1)^s \exp(-(2s+1)\gamma\tau) \left( \frac{\tau^2}{\gamma(2s+1)} + \frac{2\tau}{\gamma^2(2s+1)^2} + \frac{2}{\gamma^3(2s+1)^3} \right).$$

Частные случаи для неопределенного интеграла 2-ого рода от функций 0-5 порядков:

$$\int \tau^2 P_0^{(0,1)}(\tau, \gamma) d\tau = -\frac{1}{\gamma^3} \exp(-\gamma\tau) (\gamma^2 \tau^2 + 2\gamma\tau + 2);$$

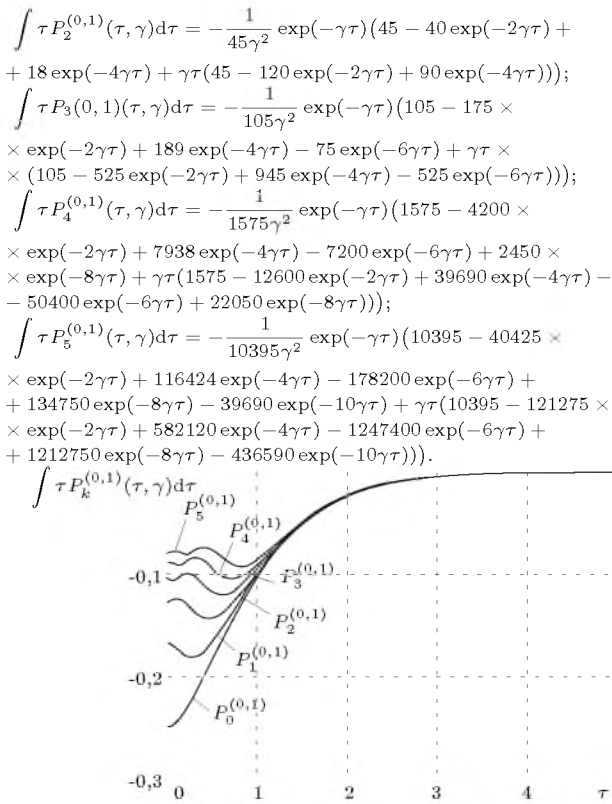
$$\int \tau^2 P_1^{(0,1)}(\tau, \gamma) d\tau = -\frac{1}{9\gamma^3} \exp(-\gamma\tau) (18 - 2 \exp(-2\gamma\tau) + \gamma\tau(18 - 6 \exp(-2\gamma\tau) + \gamma^2 \tau^2(9 - 9 \exp(-2\gamma\tau)));$$

$$\int \tau^2 P_2^{(0,1)}(\tau, \gamma) d\tau = -\frac{1}{675\gamma^3} \exp(-\gamma\tau) (1350 - 400 \times \exp(-2\gamma\tau) + 108 \exp(-4\gamma\tau) + \gamma\tau(1350 - 1200 \exp(-2\gamma\tau) + 540 \exp(-4\gamma\tau)) + \gamma^2 \tau^2(675 - 1800 \exp(-2\gamma\tau) + 1350 \times \exp(-4\gamma\tau)));$$

$$\int \tau^2 P_3^{(0,1)}(\tau, \gamma) d\tau = -\frac{1}{11025\gamma^3} \exp(-\gamma\tau) (22050 - 12250 \times \exp(-2\gamma\tau) + 7938 \exp(-4\gamma\tau) - 2250 \exp(-6\gamma\tau) + \gamma\tau \times (22050 - 36750 \exp(-2\gamma\tau) + 39690 \exp(-4\gamma\tau) - 15750 \times$$

$$\times \exp(-6\gamma\tau)) + \gamma^2 \tau^2(11025 - 55125 \exp(-2\gamma\tau) + 99225 \times \exp(-4\gamma\tau) - 55125 \exp(-6\gamma\tau)));$$

$$\int \tau^2 P_4^{(0,1)}(\tau, \gamma) d\tau = -\frac{1}{496125\gamma^3} \exp(-\gamma\tau) (992250 - 882000 \exp(-2\gamma\tau) + 1000188 \exp(-4\gamma\tau) - 648000 \times \exp(-6\gamma\tau) + 171500 \exp(-8\gamma\tau) + \gamma\tau(992250 - 2646000 \times \exp(-2\gamma\tau) + 5000940 \exp(-4\gamma\tau) - 4536000 \exp(-6\gamma\tau) + 1543500 \exp(-8\gamma\tau)) + \gamma^2 \tau^2(496125 - 3969000 \exp(-2\gamma\tau) + 12502350 \exp(-4\gamma\tau) - 15876000 \exp(-6\gamma\tau) + 6945750 \times \exp(-8\gamma\tau)));$$

$$\int \tau^2 P_5^{(0,1)}(\tau, \gamma) d\tau = -\frac{1}{36018675\gamma^3} \exp(-\gamma\tau) (72037350 - 93381750 \exp(-2\gamma\tau) + 161363664 \exp(-4\gamma\tau) - 176418000 \times \exp(-6\gamma\tau) + 103757500 \exp(-8\gamma\tau) - 25004700 \exp(-10\gamma\tau) + \gamma\tau(72037350 - 280145250 \exp(-2\gamma\tau) + 806818320 \times \exp(-4\gamma\tau) - 1234926000 \exp(-6\gamma\tau) + 933817500 \times \exp(-8\gamma\tau) - 275051700 \exp(-10\gamma\tau)) + \gamma^2 \tau^2 \times (36018675 - 420217875 \exp(-2\gamma\tau) + 2017045800 \exp(-4\gamma\tau) - 4322241000 \exp(-6\gamma\tau) + 4202178750 \exp(-8\gamma\tau) - 1512784350 \exp(-10\gamma\tau))).$$

$$\int \tau^2 P_k^{(0,1)}(\tau, \gamma) d\tau$$



Рис. 1.118. Вид неопределенного интеграла 2-ого рода от ортогональных функций Якоби 0-5 порядков;  $\gamma = 2$ ,  $c = 2$ ,  $\alpha = 0$ ,  $\beta = 1$

$$[1.119] \quad \int \tau^3 P_k^{(0,1)}(\tau, \gamma) d\tau = -\sum_{s=0}^k \binom{k}{s} \binom{k+s+1}{s} \times (-1)^s \exp(-(2s+1)\gamma\tau) \left( \frac{\tau^3}{\gamma(2s+1)} + \frac{3\tau^2}{\gamma^2(2s+1)^2} + \frac{6\tau}{\gamma^3(2s+1)^3} + \frac{6}{\gamma^4(2s+1)^4} \right).$$

Частные случаи для неопределенного интеграла 3-ого рода от функций 0-5 порядков:

$$\int \tau^3 P_0^{(0,1)}(\tau, \gamma) d\tau = -\frac{1}{\gamma^4} \exp(-\gamma\tau) (\gamma^3 \tau^3 + 3\gamma^2 \tau^2 + 6\gamma\tau + 6);$$

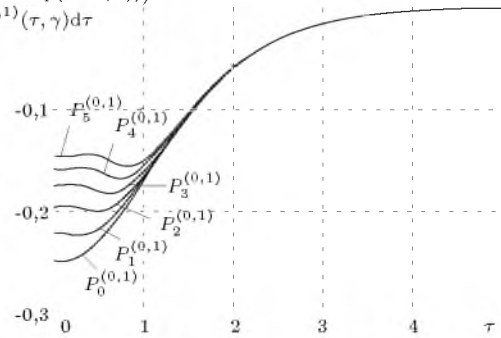
$$\int \tau^3 P_1^{(0,1)}(\tau, \gamma) d\tau = -\frac{1}{9\gamma^4} \exp(-\gamma\tau) (54 - 2 \exp(-2\gamma\tau) + \gamma\tau(54 - 6 \exp(-2\gamma\tau) + \gamma^2 \tau^2(27 - 9 \exp(-2\gamma\tau)) + \gamma^3 \tau^3 \times (9 - 9 \exp(-2\gamma\tau)));$$

$$\int \tau^3 P_2^{(0,1)}(\tau, \gamma) d\tau = -\frac{1}{3375\gamma^4} \exp(-\gamma\tau) (20250 - 2000 \times \exp(-2\gamma\tau) + 324 \exp(-4\gamma\tau) + \gamma\tau(20250 - 6000 \exp(-2\gamma\tau) + 1620 \exp(-4\gamma\tau)) + \gamma^2 \tau^2(10125 - 9000 \exp(-2\gamma\tau) + 4050 \times \exp(-4\gamma\tau)) + \gamma^3 \tau^3(3375 - 9000 \exp(-2\gamma\tau) + 6750 \times \exp(-4\gamma\tau)));$$

$$\int \tau^3 P_3^{(0,1)}(\tau, \gamma) d\tau = -\frac{1}{385875\gamma^4} \exp(-\gamma\tau) (2315250 -$$

$$\begin{aligned}
 & - 428750 \exp(-2\gamma\tau) + 166698 \exp(-4\gamma\tau) - 33750 \exp(-6\gamma\tau) + \\
 & + \gamma\tau(2315250 - 1286250 \exp(-2\gamma\tau) + 833490 \exp(-4\gamma\tau) - \\
 & - 236250 \exp(-6\gamma\tau)) + \gamma^2\tau^2(1157625 - 1929375 \exp(-2\gamma\tau) + \\
 & + 2083725 \exp(-4\gamma\tau) - 826875 \exp(-6\gamma\tau)) + \gamma^3\tau^3 \times \\
 & \times (385875 - 1929375 \exp(-2\gamma\tau) + 3472875 \exp(-4\gamma\tau) - \\
 & - 1929375 \exp(-6\gamma\tau)); \\
 & \int \tau^3 P_4^{(0,1)}(\tau, \gamma) d\tau = -\frac{1}{52093125\gamma^4} \exp(-\gamma\tau) (312558750 - \\
 & - 92610000 \exp(-2\gamma\tau) + 63011844 \exp(-4\gamma\tau) - 29160000 \times \\
 & \times \exp(-6\gamma\tau) + 6002500 \exp(-8\gamma\tau) + \gamma\tau(312558750 - \\
 & - 277830000 \exp(-2\gamma\tau) + 315059220 \exp(-4\gamma\tau) - 204120000 \times \\
 & \times \exp(-6\gamma\tau) + 54022500 \exp(-8\gamma\tau)) + \gamma^2\tau^2(156279375 - \\
 & - 416745000 \exp(-2\gamma\tau) + 787648050 \exp(-4\gamma\tau) - 714420000 \times \\
 & \times \exp(-6\gamma\tau) + 243101250 \exp(-8\gamma\tau)) + \gamma^3\tau^3(52093125 - \\
 & - 787648050 \exp(-2\gamma\tau) + 1312746750 \exp(-4\gamma\tau) - \\
 & - 1666980000 \exp(-6\gamma\tau) + 729303750 \exp(-8\gamma\tau)); \\
 & \int \tau^3 P_5^{(0,1)}(\tau, \gamma) d\tau = -\frac{1}{41601569625\gamma^4} \exp(-\gamma\tau) \times \\
 & \times (249609417750 - 107855921250 \exp(-2\gamma\tau) + 111825019152 \times \\
 & \times \exp(-4\gamma\tau) - 87326910000 \exp(-6\gamma\tau) + 39946637500 \times \\
 & \times \exp(-8\gamma\tau) - 7876480500 \exp(-10\gamma\tau) + \gamma\tau(249609417750 - \\
 & - 323567763750 \exp(-2\gamma\tau) + 559125095760 \exp(-4\gamma\tau) - \\
 & - 611288370000 \exp(-6\gamma\tau) + 359519737500 \exp(-8\gamma\tau) - \\
 & - 86641285500 \exp(-10\gamma\tau)) + \gamma^2\tau^2(124804708875 - \\
 & - 485351645625 \exp(-2\gamma\tau) + 1397812739400 \exp(-4\gamma\tau) - \\
 & - 2139509295000 \exp(-6\gamma\tau) + 1617838818750 \exp(-8\gamma\tau) - \\
 & - 476527070250 \exp(-10\gamma\tau)) + \gamma^3\tau^3(41601569625 - \\
 & - 485351645625 \exp(-2\gamma\tau) + 2329687899000 \exp(-4\gamma\tau) - \\
 & - 4992188355000 \exp(-6\gamma\tau) + 4853516456250 \exp(-8\gamma\tau) - \\
 & - 1747265924250 \exp(-10\gamma\tau)). \\
 & \int \tau^3 P_k^{(0,1)}(\tau, \gamma) d\tau
 \end{aligned}$$



Рис. 1.119. Вид неопределенного интеграла 3-го рода от ортогональных функций Якоби 0-5 порядков;  $\gamma = 2, c = 2, \alpha = 0, \beta = 1$

$$\begin{aligned}
 [1.120] \quad \int \tau^n P_k^{(0,1)}(\tau, \gamma) d\tau &= - \sum_{s=0}^k \binom{k}{s} \binom{k+s+1}{s} \times \\
 &\times (-1)^s \exp(-(2s+1)\gamma\tau) \sum_{j=0}^n \frac{n! \tau^{n-j}}{(n-j)! (\gamma(2s+1))^{j+1}}.
 \end{aligned}$$

Частные случаи для неопределенного интеграла n-го рода от функций 0-5 порядков:

$$\int \tau^n P_0^{(0,1)}(\tau, \gamma) d\tau = -\frac{2n!}{\gamma} \exp(-\gamma\tau) \sum_{j=0}^n \left(\frac{2}{\gamma}\right)^j \frac{\tau^{n-j}}{(n-j)!};$$

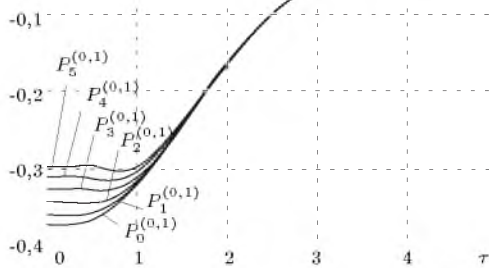
$$\int \tau^n P_1^{(0,1)}(\tau, \gamma) d\tau = -\exp(-\gamma\tau) \times$$

$$\begin{aligned}
 & \times \left( n! \sum_{j=0}^n \frac{\tau^{n-j}}{(n-j)! (\gamma)^{j+1}} - \right. \\
 & \left. - 3n! \exp(-2\gamma\tau) \sum_{j=0}^n \frac{\tau^{n-j}}{(n-j)! (3\gamma)^{j+1}} \right); \\
 & \int \tau^n P_2^{(0,1)}(\tau, \gamma) d\tau = -\exp(-\gamma\tau) \times \\
 & \times \left( n! \sum_{j=0}^n \frac{\tau^{n-j}}{(n-j)! (\gamma)^{j+1}} - \right. \\
 & \left. - 8n! \exp(-2\gamma\tau) \sum_{j=0}^n \frac{\tau^{n-j}}{(n-j)! (3\gamma)^{j+1}} + \right. \\
 & \left. + 10n! \exp(-4\gamma\tau) \sum_{j=0}^n \frac{\tau^{n-j}}{(n-j)! (5\gamma)^{j+1}} \right); \\
 & \int \tau^n P_3^{(0,1)}(\tau, \gamma) d\tau = -\exp(-\gamma\tau) \times \\
 & \times \left( n! \sum_{j=0}^n \frac{\tau^{n-j}}{(n-j)! (\gamma)^{j+1}} - \right. \\
 & \left. - 15n! \exp(-2\gamma\tau) \sum_{j=0}^n \frac{\tau^{n-j}}{(n-j)! (3\gamma)^{j+1}} + \right. \\
 & \left. + 45n! \exp(-4\gamma\tau) \sum_{j=0}^n \frac{\tau^{n-j}}{(n-j)! (5\gamma)^{j+1}} - \right. \\
 & \left. - 35n! \exp(-6\gamma\tau) \sum_{j=0}^n \frac{\tau^{n-j}}{(n-j)! (7\gamma)^{j+1}} \right); \\
 & \int \tau^n P_4^{(0,1)}(\tau, \gamma) d\tau = -\exp(-\gamma\tau) \times \\
 & \times \left( n! \sum_{j=0}^n \frac{\tau^{n-j}}{(n-j)! (3\gamma)^{j+1}} - \right. \\
 & \left. - 24n! \exp(-2\gamma\tau) \sum_{j=0}^n \frac{\tau^{n-j}}{(n-j)! (5\gamma)^{j+1}} + \right. \\
 & \left. + 126n! \exp(-4\gamma\tau) \sum_{j=0}^n \frac{\tau^{n-j}}{(n-j)! (7\gamma)^{j+1}} - \right. \\
 & \left. - 224n! \exp(-6\gamma\tau) \sum_{j=0}^n \frac{\tau^{n-j}}{(n-j)! (9\gamma)^{j+1}} + \right. \\
 & \left. + 126n! \exp(-8\gamma\tau) \sum_{j=0}^n \frac{\tau^{n-j}}{(n-j)! (11\gamma)^{j+1}} \right); \\
 & \int \tau^n P_5^{(0,1)}(\tau, \gamma) d\tau = -\exp(-\gamma\tau) \times \\
 & \times \left( n! \sum_{j=0}^n \frac{\tau^{n-j}}{(n-j)! (\gamma)^{j+1}} - \right. \\
 & \left. - 35n! \exp(-2\gamma\tau) \sum_{j=0}^n \frac{\tau^{n-j}}{(n-j)! (3\gamma)^{j+1}} + \right. \\
 & \left. + 280n! \exp(-4\gamma\tau) \sum_{j=0}^n \frac{\tau^{n-j}}{(n-j)! (5\gamma)^{j+1}} - \right. \\
 & \left. - 840n! \exp(-6\gamma\tau) \sum_{j=0}^n \frac{\tau^{n-j}}{(n-j)! (7\gamma)^{j+1}} + \right.
 \end{aligned}$$



Рис. 1.120. Вид неопределенного интеграла n-ого рода от ортогональных функций Якоби 2-ого порядка;  $n = 0..5$ ,  $\gamma = 2$ ,  $c = 2$ ,  $\alpha = 0$ ,  $\beta = 1$

$$[1.121] \quad \int P_k^{(0,2)}(\tau, \gamma) d\tau = - \sum_{s=0}^k \binom{k}{s} \binom{k+s+2}{s} \times \\ \times \frac{(-1)^s}{\gamma(2s+1)} \exp(-(2s+1)\gamma\tau).$$

Частные случаи для неопределенного интеграла от функций 0-5 порядков:

$$\int P_0^{(0,2)}(\tau, \gamma) d\tau = -\frac{1}{\gamma} \exp(-\gamma\tau);$$

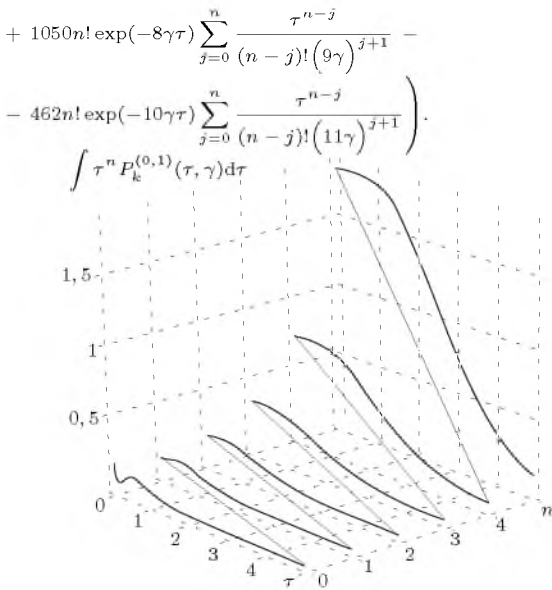
$$\int P_1^{(0,2)}(\tau, \gamma) d\tau = -\frac{1}{3\gamma} \exp(-\gamma\tau)(3 - 4 \exp(-2\gamma\tau));$$

$$\int P_2^{(0,2)}(\tau, \gamma) d\tau = -\frac{1}{3\gamma} \exp(-\gamma\tau)(3 - 10 \exp(-2\gamma\tau) + 9 \times \\ \times \exp(-4\gamma\tau));$$

$$\int P_3^{(0,2)}(\tau, \gamma) d\tau = -\frac{1}{5\gamma} \exp(-\gamma\tau)(5 - 30 \exp(-2\gamma\tau) + 63 \times \\ \times \exp(-4\gamma\tau) - 40 \exp(-6\gamma\tau));$$

$$\int P_4^{(0,2)}(\tau, \gamma) d\tau = -\frac{1}{15\gamma} \exp(-\gamma\tau)(15 - 140 \exp(-2\gamma\tau) + \\ + 504 \exp(-4\gamma\tau) - 720 \exp(-6\gamma\tau) + 350 \exp(-8\gamma\tau));$$

$$\int P_5^{(0,2)}(\tau, \gamma) d\tau = -\frac{1}{21\gamma} \exp(-\gamma\tau)(21 - 280 \exp(-2\gamma\tau) + \\ + 1512 \exp(-4\gamma\tau) - 3600 \exp(-6\gamma\tau) + 3850 \exp(-8\gamma\tau) - \\ - 1512 \exp(-10\gamma\tau)).$$



Рис. 1.121. Вид неопределенного интеграла от ортогональных функций Якоби 0-5 порядков;  $\gamma = 2$ ,  $c = 2$ ,  $\alpha = 0$ ,  $\beta = 2$

$$[1.122] \quad \int \tau P_k^{(0,2)}(\tau, \gamma) d\tau = - \sum_{s=0}^k \binom{k}{s} \binom{k+s+2}{s} \times \\ \times (-1)^s \exp(-(2s+1)\gamma\tau) \left( \frac{\tau}{\gamma(2s+1)} + \frac{1}{\gamma^2(2s+1)^2} \right).$$

Частные случаи для неопределенного интеграла 1-ого рода от функций 0-5 порядков:

$$\int \tau P_0^{(0,2)}(\tau, \gamma) d\tau = -\frac{1}{\gamma^2} \exp(-\gamma\tau)(\gamma\tau + 1);$$

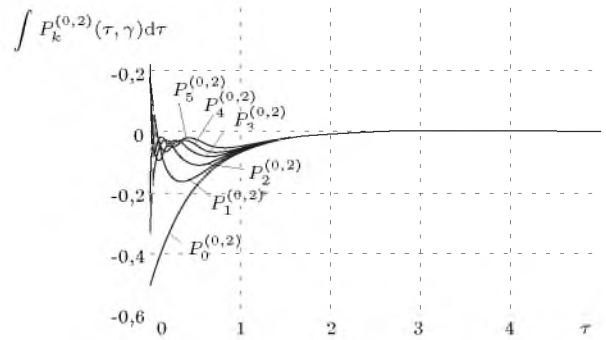
$$\int \tau P_1^{(0,2)}(\tau, \gamma) d\tau = -\frac{1}{9\gamma^2} \exp(-\gamma\tau)(9 - 4 \exp(-2\gamma\tau) + \gamma\tau(9 - \\ - 12 \exp(-2\gamma\tau)));$$

$$\int \tau P_2^{(0,2)}(\tau, \gamma) d\tau = -\frac{1}{45\gamma^2} \exp(-\gamma\tau)(45 - 50 \exp(-2\gamma\tau) + \\ + 27 \exp(-4\gamma\tau) + \gamma\tau(45 - 150 \exp(-2\gamma\tau) + 135 \exp(-4\gamma\tau)));$$

$$\int \tau P_3^{(0,2)}(\tau, \gamma) d\tau = -\frac{1}{175\gamma^2} \exp(-\gamma\tau)(175 - 350 \times \\ \times \exp(-2\gamma\tau) + 441 \exp(-4\gamma\tau) - 200 \exp(-6\gamma\tau) + \gamma\tau(175 - \\ - 1050 \exp(-2\gamma\tau) + 2205 \exp(-4\gamma\tau) - 1400 \exp(-6\gamma\tau)));$$

$$\int \tau P_4^{(0,2)}(\tau, \gamma) d\tau = -\frac{1}{4725\gamma^2} \exp(-\gamma\tau)(4725 - 14700 \times \\ \times \exp(-2\gamma\tau) + 31752 \exp(-4\gamma\tau) - 32400 \exp(-6\gamma\tau) + \\ + 12250 \exp(-8\gamma\tau) + \gamma\tau(4725 - 44100 \exp(-2\gamma\tau) + \\ + 158760 \exp(-4\gamma\tau) - 226800 \exp(-6\gamma\tau) + 110250 \exp(-8\gamma\tau)));$$

$$\int \tau P_5^{(0,2)}(\tau, \gamma) d\tau = -\frac{1}{72765\gamma^2} \exp(-\gamma\tau)(72765 - \\ - 323400 \exp(-2\gamma\tau) + 1047816 \exp(-4\gamma\tau) - 1782000 \times \\ \times \exp(-6\gamma\tau) + 1482250 \exp(-8\gamma\tau) - 476280 \exp(-10\gamma\tau) + \gamma\tau \times \\ \times (72765 - 970200 \exp(-2\gamma\tau) + 5239080 \exp(-4\gamma\tau) - 12474000 \times \\ \times \exp(-6\gamma\tau) + 13340250 \exp(-8\gamma\tau) - 5239080 \exp(-10\gamma\tau))).$$



Рис. 1.122. Вид неопределенного интеграла 1-ого рода от ортогональных функций Якоби 0-5 порядков;  $\gamma = 2, c = 2, \alpha = 0, \beta = 2$

$$+ 18153412200 \exp(-4\gamma\tau) - 43222410000 \exp(-6\gamma\tau) + 46223966250 \exp(-8\gamma\tau) - 18153412200 \exp(-10\gamma\tau)),$$

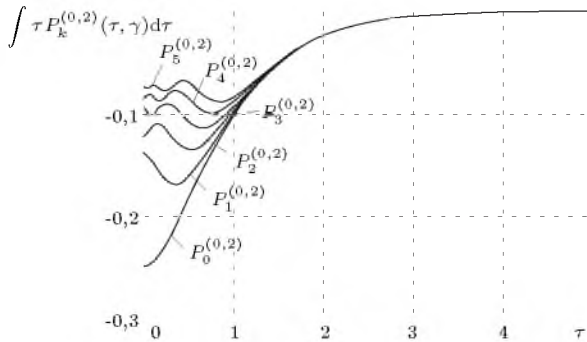

Рис. 1.123. Вид неопределенного интеграла 2-ого рода от ортогональных функций Якоби 0-5 порядков;  $\gamma = 2, c = 2, \alpha = 0, \beta = 2$

$$[1.123] \quad \int \tau^2 P_k^{(0,2)}(\tau, \gamma) d\tau = - \sum_{s=0}^k \binom{k}{s} \binom{k+s+2}{s} \times (-1)^s \exp(-(2s+1)\gamma\tau) \left( \frac{\tau^2}{\gamma(2s+1)} + \frac{2\tau}{\gamma^2(2s+1)^2} + \frac{2}{\gamma^3(2s+1)^3} \right).$$

Частные случаи для неопределенного интеграла 2-ого рода от функций 0-5 порядков:

$$\begin{aligned} \int \tau^2 P_0^{(0,2)}(\tau, \gamma) d\tau &= -\frac{1}{\gamma^3} \exp(-\gamma\tau)(\gamma^2 \tau^2 + 2\gamma\tau + 2); \\ \int \tau^2 P_1^{(0,2)}(\tau, \gamma) d\tau &= -\frac{1}{27\gamma^3} \exp(-\gamma\tau)(54 - 8 \exp(-2\gamma\tau) + \gamma\tau(54 - 24 \exp(-2\gamma\tau) + \gamma^2 \tau^2(27 - 36 \exp(-2\gamma\tau))); \\ \int \tau^2 P_2^{(0,2)}(\tau, \gamma) d\tau &= -\frac{1}{675\gamma^3} \exp(-\gamma\tau)(1350 - 500 \times \exp(-2\gamma\tau) + 162 \exp(-4\gamma\tau) + \gamma\tau(1350 - 1500 \exp(-2\gamma\tau) + 810 \exp(-4\gamma\tau)) + \gamma^2 \tau^2(675 - 2250 \exp(-2\gamma\tau) + 2025 \times \exp(-4\gamma\tau))); \\ \int \tau^2 P_3^{(0,2)}(\tau, \gamma) d\tau &= -\frac{1}{18375\gamma^3} \exp(-\gamma\tau)(36750 - 24500 \times \exp(-2\gamma\tau) + 18522 \exp(-4\gamma\tau) - 6000 \exp(-6\gamma\tau) + \gamma\tau(36750 - 73500 \exp(-2\gamma\tau) + 92610 \exp(-4\gamma\tau) - 42000 \exp(-6\gamma\tau)) + \gamma^2 \tau^2(18375 - 110250 \exp(-2\gamma\tau) + 231525 \exp(-4\gamma\tau) - 147000 \exp(-6\gamma\tau))); \\ \int \tau^2 P_4^{(0,2)}(\tau, \gamma) d\tau &= -\frac{1}{1488375\gamma^3} \exp(-\gamma\tau)(2976750 - 3087000 \exp(-2\gamma\tau) + 4000752 \exp(-4\gamma\tau) - 2916000 \times \exp(-6\gamma\tau) + 857500 \exp(-8\gamma\tau) + \gamma\tau(2976750 - 9261000 \times \exp(-2\gamma\tau) + 20003760 \exp(-4\gamma\tau) - 20412000 \exp(-6\gamma\tau) + 7717500 \exp(-8\gamma\tau)) + \gamma^2 \tau^2(1488375 - 13891500 \exp(-2\gamma\tau) + 50009400 \exp(-4\gamma\tau) - 71442000 \exp(-6\gamma\tau) + 34728750 \times \exp(-8\gamma\tau))); \\ \int \tau^2 P_5^{(0,2)}(\tau, \gamma) d\tau &= -\frac{1}{252130725\gamma^3} \exp(-\gamma\tau)(504261450 - 747054000 \exp(-2\gamma\tau) + 1452272976 \exp(-4\gamma\tau) - 1764180000 \exp(-6\gamma\tau) + 1141332500 \exp(-8\gamma\tau) - 300056400 \exp(-10\gamma\tau) + \gamma\tau(504261450 - 2241162000 \times \exp(-2\gamma\tau) + 7261364880 \exp(-4\gamma\tau) - 12349260000 \times \exp(-6\gamma\tau) + 10271992500 \exp(-8\gamma\tau) - 3300620400 \times \exp(-10\gamma\tau)) + \gamma^2 \tau^2(252130725 - 3361743000 \exp(-2\gamma\tau) + \end{aligned}$$

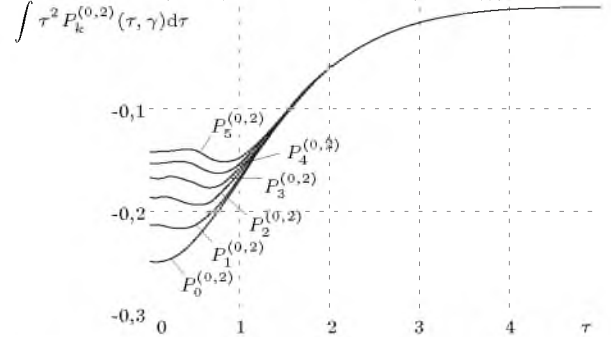
$$[1.124] \quad \int \tau^3 P_k^{(0,2)}(\tau, \gamma) d\tau = - \sum_{s=0}^k \binom{k}{s} \binom{k+s+2}{s} \times (-1)^s \exp(-(2s+1)\gamma\tau) \left( \frac{\tau^3}{\gamma(2s+1)} + \frac{3\tau^2}{\gamma^2(2s+1)^2} + \frac{6\tau}{\gamma^3(2s+1)^3} + \frac{6}{\gamma^4(2s+1)^4} \right).$$

Частные случаи для неопределенного интеграла 3-ого рода от функций 0-5 порядков:

$$\begin{aligned} \int \tau^3 P_0^{(0,2)}(\tau, \gamma) d\tau &= -\frac{1}{\gamma^4} \exp(-\gamma\tau)(\gamma^3 \tau^3 + 3\gamma^2 \tau^2 + 6\gamma\tau + 6); \\ \int \tau^3 P_1^{(0,2)}(\tau, \gamma) d\tau &= -\frac{1}{27\gamma^4} \exp(-\gamma\tau)(162 - 8 \exp(-2\gamma\tau) + \gamma\tau(162 - 24 \exp(-2\gamma\tau) + \gamma^2 \tau^2(81 - 36 \exp(-2\gamma\tau)) + \gamma^3 \tau^3 \times (27 - 36 \exp(-2\gamma\tau))); \\ \int \tau^3 P_2^{(0,2)}(\tau, \gamma) d\tau &= -\frac{1}{3375\gamma^4} \exp(-\gamma\tau)(20250 - 2500 \times \exp(-2\gamma\tau) + 486 \exp(-4\gamma\tau) + \gamma\tau(20250 - 7500 \exp(-2\gamma\tau) + 2430 \exp(-4\gamma\tau)) + \gamma^2 \tau^2(10125 - 11250 \exp(-2\gamma\tau) + 6075 \times \exp(-4\gamma\tau)) + \gamma^3 \tau^3(3375 - 11250 \exp(-2\gamma\tau) + 10125 \times \exp(-4\gamma\tau))); \\ \int \tau^3 P_3^{(0,2)}(\tau, \gamma) d\tau &= -\frac{1}{643125\gamma^4} \exp(-\gamma\tau)(3858750 - 857500 \exp(-2\gamma\tau) + 388962 \exp(-4\gamma\tau) - 90000 \exp(-6\gamma\tau) + \gamma\tau(3858750 - 2572500 \exp(-2\gamma\tau) + 1944810 \exp(-4\gamma\tau) - 630000 \exp(-6\gamma\tau)) + \gamma^2 \tau^2(1929375 - 3858750 \exp(-2\gamma\tau) + 4862025 \exp(-4\gamma\tau) - 2205000 \exp(-6\gamma\tau)) + \gamma^3 \tau^3(643125 - 3858750 \exp(-2\gamma\tau) + 8103375 \exp(-4\gamma\tau) - 5145000 \times \exp(-6\gamma\tau))); \\ \int \tau^3 P_4^{(0,2)}(\tau, \gamma) d\tau &= -\frac{1}{156279375\gamma^4} \exp(-\gamma\tau)(937676250 - 324135000 \exp(-2\gamma\tau) + 252047376 \exp(-4\gamma\tau) - 131220000 \times \exp(-6\gamma\tau) + 30012500 \exp(-8\gamma\tau) + \gamma\tau(937676250 - 972405000 \exp(-2\gamma\tau) + 1260236880 \exp(-4\gamma\tau) - 918540000 \times \exp(-6\gamma\tau) + 270112500 \exp(-8\gamma\tau)) + \gamma^2 \tau^2(468838125 - 1458607500 \exp(-2\gamma\tau) + 3150592200 \exp(-4\gamma\tau) - 3214890000 \exp(-6\gamma\tau) + 1215506250 \exp(-8\gamma\tau)) + \gamma^3 \tau^3 \times (156279375 - 787648050 \exp(-2\gamma\tau) + 5250987000 \times \exp(-4\gamma\tau) - 7501410000 \exp(-6\gamma\tau) + 3646518750 \times \exp(-8\gamma\tau))); \end{aligned}$$



Рис. 1.124. Вид неопределенного интеграла 3-ого рода от ортогональных функций Якоби 0-5 порядков;  $\gamma = 2, c = 2, \alpha = 0, \beta = 2$

$$[1.125] \quad \int \tau^n P_k^{(0,2)}(\tau, \gamma) d\tau = - \sum_{s=0}^k \binom{k}{s} \binom{k+s+2}{s} \times (-1)^s \exp(-(2s+1)\gamma\tau) \sum_{j=0}^n \frac{n! \tau^{n-j}}{(n-j)! (\gamma(2s+1))^{j+1}}.$$

Частные случаи для неопределенного интеграла n-ого рода от функций 0-5 порядков:

$$\begin{aligned} \int \tau^n P_0^{(0,2)}(\tau, \gamma) d\tau &= -\frac{2n!}{\gamma} \exp(-\gamma\tau) \sum_{j=0}^n \left(\frac{2}{\gamma}\right)^j \frac{\tau^{n-j}}{(n-j)!}; \\ \int \tau^n P_1^{(0,2)}(\tau, \gamma) d\tau &= -\exp(-\gamma\tau) \times \\ &\times \left( n! \sum_{j=0}^n \frac{\tau^{n-j}}{(n-j)! (\gamma)^{j+1}} - \right. \\ &\left. - 4n! \exp(-2\gamma\tau) \sum_{j=0}^n \frac{\tau^{n-j}}{(n-j)! (3\gamma)^{j+1}} \right); \\ \int \tau^n P_2^{(0,2)}(\tau, \gamma) d\tau &= -\exp(-\gamma\tau) \times \\ &\times \left( n! \sum_{j=0}^n \frac{\tau^{n-j}}{(n-j)! (\gamma)^{j+1}} - \right. \\ &\left. - 10n! \exp(-2\gamma\tau) \sum_{j=0}^n \frac{\tau^{n-j}}{(n-j)! (3\gamma)^{j+1}} + \right. \end{aligned}$$

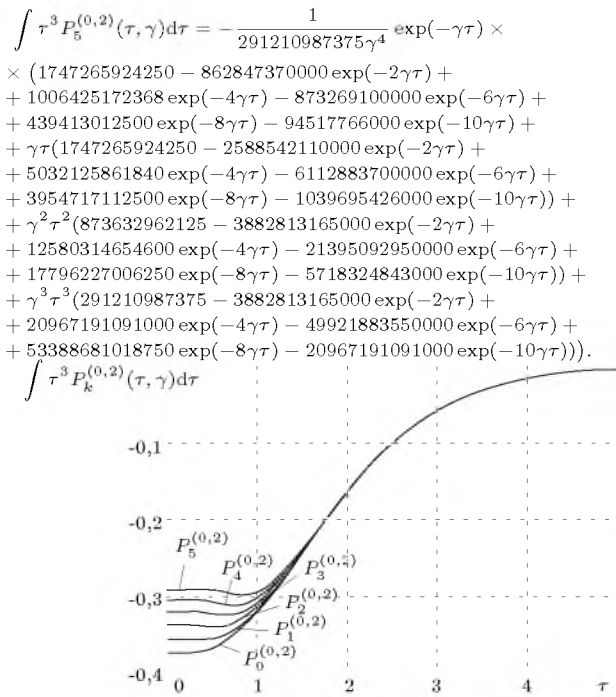
$$\begin{aligned} &\left. + 15n! \exp(-4\gamma\tau) \sum_{j=0}^n \frac{\tau^{n-j}}{(n-j)! (5\gamma)^{j+1}} \right); \\ \int \tau^n P_3^{(0,2)}(\tau, \gamma) d\tau &= -\exp(-\gamma\tau) \times \\ &\times \left( n! \sum_{j=0}^n \frac{\tau^{n-j}}{(n-j)! (\gamma)^{j+1}} - \right. \\ &\left. - 18n! \exp(-2\gamma\tau) \sum_{j=0}^n \frac{\tau^{n-j}}{(n-j)! (3\gamma)^{j+1}} + \right. \\ &\left. + 63n! \exp(-4\gamma\tau) \sum_{j=0}^n \frac{\tau^{n-j}}{(n-j)! (5\gamma)^{j+1}} - \right. \\ &\left. - 56n! \exp(-6\gamma\tau) \sum_{j=0}^n \frac{\tau^{n-j}}{(n-j)! (7\gamma)^{j+1}} \right); \\ \int \tau^n P_4^{(0,2)}(\tau, \gamma) d\tau &= -\exp(-\gamma\tau) \times \\ &\times \left( n! \sum_{j=0}^n \frac{\tau^{n-j}}{(n-j)! (3\gamma)^{j+1}} - \right. \\ &\left. - 28n! \exp(-2\gamma\tau) \sum_{j=0}^n \frac{\tau^{n-j}}{(n-j)! (5\gamma)^{j+1}} + \right. \\ &\left. + 168n! \exp(-4\gamma\tau) \sum_{j=0}^n \frac{\tau^{n-j}}{(n-j)! (7\gamma)^{j+1}} - \right. \\ &\left. - 336n! \exp(-6\gamma\tau) \sum_{j=0}^n \frac{\tau^{n-j}}{(n-j)! (9\gamma)^{j+1}} + \right. \\ &\left. + 210n! \exp(-8\gamma\tau) \sum_{j=0}^n \frac{\tau^{n-j}}{(n-j)! (11\gamma)^{j+1}} \right); \\ \int \tau^n P_5^{(0,2)}(\tau, \gamma) d\tau &= -\exp(-\gamma\tau) \times \\ &\times \left( n! \sum_{j=0}^n \frac{\tau^{n-j}}{(n-j)! (\gamma)^{j+1}} - \right. \\ &\left. - 40n! \exp(-2\gamma\tau) \sum_{j=0}^n \frac{\tau^{n-j}}{(n-j)! (3\gamma)^{j+1}} + \right. \\ &\left. + 360n! \exp(-4\gamma\tau) \sum_{j=0}^n \frac{\tau^{n-j}}{(n-j)! (5\gamma)^{j+1}} - \right. \\ &\left. - 1200n! \exp(-6\gamma\tau) \sum_{j=0}^n \frac{\tau^{n-j}}{(n-j)! (7\gamma)^{j+1}} + \right. \\ &\left. + 1650n! \exp(-8\gamma\tau) \sum_{j=0}^n \frac{\tau^{n-j}}{(n-j)! (9\gamma)^{j+1}} - \right. \\ &\left. - 792n! \exp(-10\gamma\tau) \sum_{j=0}^n \frac{\tau^{n-j}}{(n-j)! (11\gamma)^{j+1}} \right). \end{aligned}$$



Рис. 1.125. Вид неопределенного интеграла n-ого рода от ортогональных функций Якоби 2-ого порядка;  $n = 0..5$ ,  $\gamma = 2$ ,  $c = 2$ ,  $\alpha = 0$ ,  $\beta = 2$

$$[1.126] \quad \int P_k^{(0,\beta)}(\tau, \gamma) d\tau = - \sum_{s=0}^k \binom{k}{s} \binom{k+s+\beta}{s} \times \frac{2(-1)^s}{c\gamma(2s+1)} \exp(-(2s+1)c\gamma\tau/2).$$

Частные случаи для неопределенного интеграла от функций 0-5 порядков:

$$\begin{aligned} \int P_0^{(0,\beta)}(\tau, \gamma) d\tau &= -\frac{2}{c\gamma} \exp(-(2s+1)c\gamma\tau/2); \\ \int P_1^{(0,\beta)}(\tau, \gamma) d\tau &= -\frac{2}{3c\gamma} \exp(-(2s+1)c\gamma\tau/2) (3 - (\beta+2) \times \\ &\times \exp(-c\gamma\tau)); \\ \int P_2^{(0,\beta)}(\tau, \gamma) d\tau &= -\frac{1}{15c\gamma} \exp(-(2s+1)c\gamma\tau/2) (30 - 20 \times \\ &\times (\beta+3) \exp(-c\gamma\tau) + 3(\beta^2 + 7\beta + 12) \exp(-2c\gamma\tau)); \\ \int P_3^{(0,\beta)}(\tau, \gamma) d\tau &= -\frac{1}{105c\gamma} \exp(-(2s+1)c\gamma\tau/2) (210 - 210 \times \\ &\times (\beta+4) \exp(-c\gamma\tau) + 63(\beta^2 + 9\beta + 20) \exp(-2c\gamma\tau) - 5 \times \\ &\times (\beta^3 + 15\beta^2 + 74\beta + 120) \exp(-3c\gamma\tau)); \\ \int P_4^{(0,\beta)}(\tau, \gamma) d\tau &= -\frac{1}{3780c\gamma} \exp(-(2s+1)c\gamma\tau/2) \times \\ &\times (7560 - 10080(\beta+5) \exp(-c\gamma\tau) + 4536(\beta^2 + 11\beta + 30) \times \\ &\times \exp(-2c\gamma\tau) - 720(\beta^3 + 18\beta^2 + 107\beta + 210) \exp(-3c\gamma\tau) + 35 \times \\ &\times (\beta^4 + 26\beta^3 + 251\beta^2 + 1066\beta + 1680) \exp(-4c\gamma\tau)); \\ \int P_5^{(0,\beta)}(\tau, \gamma) d\tau &= -\frac{1}{41580c\gamma} \exp(-(2s+1)c\gamma\tau/2) \times \\ &\times (83160 - 138600(\beta+6) \exp(-c\gamma\tau) + 83160(\beta^2 + 13\beta + 42) \times \\ &\times \exp(-2c\gamma\tau) - 19800(\beta^3 + 21\beta^2 + 146\beta + 336) \exp(-3c\gamma\tau) + \\ &+ 1925(\beta^4 + 30\beta^3 + 335\beta^2 + 1650\beta + 3024) \exp(-4c\gamma\tau) - 63 \times \\ &\times (\beta^5 + 40\beta^4 + 635\beta^3 + 5000\beta^2 + 19524\beta + 30240) \exp(-5c\gamma\tau)). \end{aligned}$$

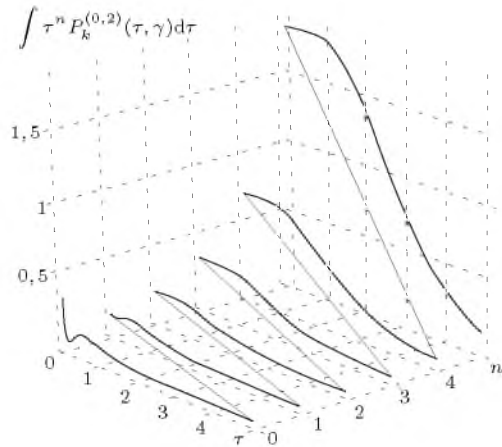

Рис. 1.126. Вид неопределенного интеграла от ортогональных функций Якоби 2-ого порядка: а)  $\gamma = 2$ ,  $\beta \in [0; 5]$ ; б)  $\gamma \in (1; 3; 5]$ ,  $\beta = 1$

$$[1.127] \quad \int \tau P_k^{(0,\beta)}(\tau, \gamma) d\tau = - \sum_{s=0}^k \binom{k}{s} \binom{k+s+\beta}{s} \times \times (-1)^s \exp(-(2s+1)c\gamma\tau/2) \left( \frac{2\tau}{c\gamma(2s+1)} + \frac{4}{c^2\gamma^2(2s+1)^2} \right).$$

Частные случаи для неопределенного интеграла 1-ого рода от функций 0-5 порядков:

$$\begin{aligned} \int \tau P_0^{(0,\beta)}(\tau, \gamma) d\tau &= -\frac{2}{c^2\gamma^2} \exp\left(-\frac{c\gamma\tau}{2}\right) (\gamma\tau + 2); \\ \int \tau P_1^{(0,\beta)}(\tau, \gamma) d\tau &= -\frac{2}{9c^2\gamma^2} \exp\left(-\frac{c\gamma\tau}{2}\right) (18 - 2(\beta+2) \times \\ &\times \exp(-c\gamma\tau) + \gamma\tau(9 - 3(\beta+2) \exp(-c\gamma\tau))); \end{aligned}$$

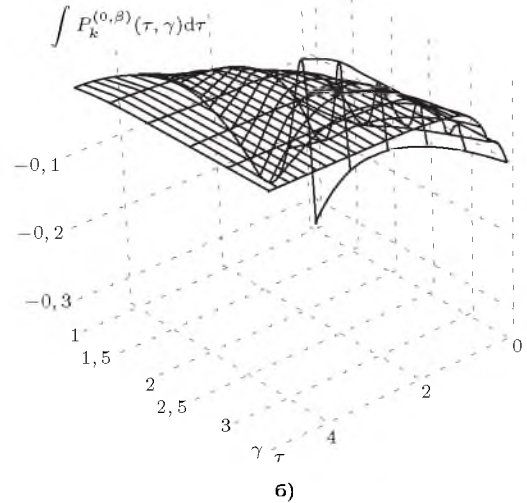
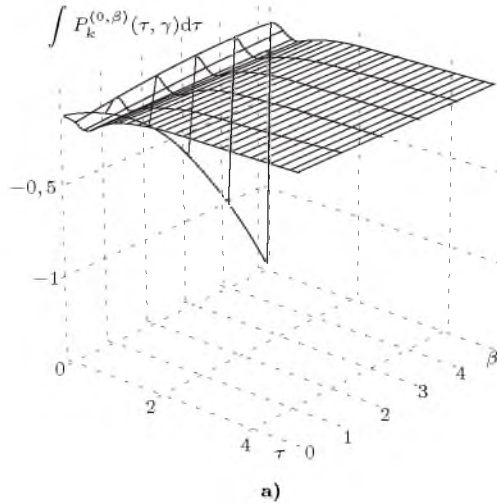
$$\int \tau P_2^{(0,\beta)}(\tau, \gamma) d\tau = -\frac{1}{225c^2\gamma^2} \exp\left(-\frac{c\gamma\tau}{2}\right) (450(c\gamma\tau + 2) - 100(\beta + 3)(3c\gamma\tau + 2) \exp(-c\gamma\tau) + 9(\beta^2 + 7\beta + 12)(5c\gamma\tau + 2) \times \exp(-2c\gamma\tau));$$

$$\int \tau P_3^{(0,\beta)}(\tau, \gamma) d\tau = -\frac{1}{3675c^2\gamma^2} \exp\left(-\frac{c\gamma\tau}{2}\right) (7350(c\gamma\tau + 2) - 2450(\beta + 4)(3c\gamma\tau + 2) \exp(-c\gamma\tau) + 441(\beta^2 + 9\beta + 20) \times (5c\gamma\tau + 2) \exp(-2c\gamma\tau) - 25(\beta^3 + 15\beta^2 + 74\beta + 120)(7c\gamma\tau + 2) \times \exp(-3c\gamma\tau));$$

$$\int \tau P_4^{(0,\beta)}(\tau, \gamma) d\tau = -\frac{1}{1190700c^2\gamma^2} \exp\left(-\frac{c\gamma\tau}{2}\right) \times (2381400(c\gamma\tau + 2) - 1058400(\beta + 5)(3c\gamma\tau + 2) \exp(-c\gamma\tau) +$$

$$+ 285768(\beta^2 + 11\beta + 30)(5c\gamma\tau + 2) \exp(-2c\gamma\tau) - 32400(\beta^3 + 18 \times \beta^2 + 107\beta + 210)(7c\gamma\tau + 2) \exp(-3c\gamma\tau) + 1225(\beta^4 + 26\beta^3 + 251\beta^2 + 1066\beta + 1680)(9c\gamma\tau + 2) \exp(-4c\gamma\tau));$$

$$\int \tau P_5^{(0,\beta)}(\tau, \gamma) d\tau = -\frac{1}{28814940c^2\gamma^2} \exp\left(-\frac{c\gamma\tau}{2}\right) \times (57629880(c\gamma\tau + 2) - 32016600(\beta + 6)(3c\gamma\tau + 2) \exp(-c\gamma\tau) + 11525976(\beta^2 + 13\beta + 42)(5c\gamma\tau + 2) \exp(-2c\gamma\tau) - 1960200 \times (\beta^3 + 21\beta^2 + 146\beta + 336)(7c\gamma\tau + 2) \exp(-3c\gamma\tau) + 148225(\beta^4 + 30\beta^3 + 335\beta^2 + 1650\beta + 3024)(9c\gamma\tau + 2) \exp(-4c\gamma\tau) - 3969 \times (\beta^5 + 40\beta^4 + 635\beta^3 + 5000\beta^2 + 19524\beta + 30240)(11c\gamma\tau + 2) \times \exp(-5c\gamma\tau)).$$



Рис. 1.127. Вид неопределенного интеграла 1-ого рода от ортогональных функций Якоби 2-ого порядка: а)  $\gamma = 2$ ,  $\beta \in [0; 5]$ ; б)  $\gamma \in \{1; 3; 5\}$ ,  $\beta = 1$

$$[1.128] \quad \int \tau^2 P_k^{(0,\beta)}(\tau, \gamma) d\tau = -\sum_{s=0}^k \binom{k}{s} \binom{k+s+\beta}{s} \times (-1)^s \exp\left(-\frac{(2s+1)c\gamma\tau}{2}\right) \left( \frac{2\tau^2}{c\gamma(2s+1)} + \frac{8\tau}{c^2\gamma^2(2s+1)^2} + \frac{16}{c^3\gamma^3(2s+1)^3} \right).$$

Частные случаи для неопределенного интеграла 2-ого рода от функций 0-5 порядков:

$$\int \tau^2 P_0^{(0,\beta)}(\tau, \gamma) d\tau = -\frac{2}{c^3\gamma^3} \exp\left(-\frac{c\gamma\tau}{2}\right) (8 + 4c\gamma\tau + c^2\gamma^2\tau^2);$$

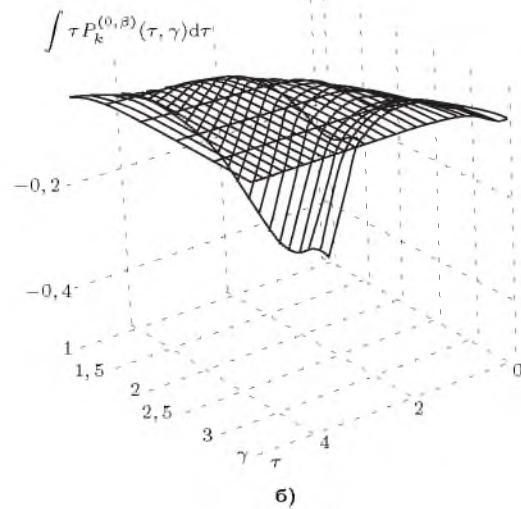
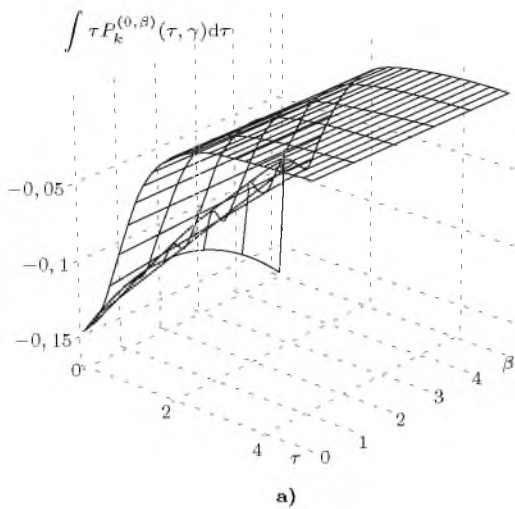
$$\int \tau^2 P_1^{(0,\beta)}(\tau, \gamma) d\tau = -\frac{2}{27c^3\gamma^3} \exp\left(-\frac{c\gamma\tau}{2}\right) (54(c^2\gamma^2\tau^2 + 4c\gamma\tau + 8) - 2(\beta + 2)(9c^2\gamma^2\tau^2 + 12c\gamma\tau + 8) \exp(-c\gamma\tau));$$

$$\int \tau^2 P_2^{(0,\beta)}(\tau, \gamma) d\tau = -\frac{1}{3375c^3\gamma^3} \exp\left(-\frac{c\gamma\tau}{2}\right) (6750(c^2\gamma^2\tau^2 + 4c\gamma\tau + 8) - 500(\beta + 3)(9c^2\gamma^2\tau^2 + 12c\gamma\tau + 8) \exp(-c\gamma\tau) + 27(\beta^2 + 7\beta + 12)(25c^2\gamma^2\tau^2 + 20c\gamma\tau + 8) \exp(-2c\gamma\tau));$$

$$\int \tau^2 P_3^{(0,\beta)}(\tau, \gamma) d\tau = -\frac{1}{385875c^3\gamma^3} \exp\left(-\frac{c\gamma\tau}{2}\right) \times$$

$$\times (771750(c^2\gamma^2\tau^2 + 4c\gamma\tau + 8) - 85750(\beta + 4)(9c^2\gamma^2\tau^2 + 12c\gamma\tau + 8) \exp(-c\gamma\tau) + 9261(\beta^2 + 9\beta + 20)(25c^2\gamma^2\tau^2 + 20c\gamma\tau + 8) \exp(-2c\gamma\tau) - 375(\beta^3 + 15\beta^2 + 74\beta + 120) \times (49c^2\gamma^2\tau^2 + 28c\gamma\tau + 8) \exp(-3c\gamma\tau));$$

$$\int \tau^2 P_4^{(0,\beta)}(\tau, \gamma) d\tau = -\frac{1}{375070500c^3\gamma^3} \exp\left(-\frac{c\gamma\tau}{2}\right) \times (750141000(c^2\gamma^2\tau^2 + 4c\gamma\tau + 8) - 111132000(\beta + 5)(9c^2\gamma^2\tau^2 + 12c\gamma\tau + 8) \exp(-c\gamma\tau) + 18003384(\beta^2 + 11\beta + 30)(25c^2\gamma^2\tau^2 + 20c\gamma\tau + 8) \exp(-2c\gamma\tau) - 1458000(\beta^3 + 18\beta^2 + 107\beta + 210) \times (49c^2\gamma^2\tau^2 + 28c\gamma\tau + 8) \exp(-3c\gamma\tau) + 42875(\beta^4 + 26\beta^3 + 251 \times \beta^2 + 1066\beta + 1680)(81c^2\gamma^2\tau^2 + 36c\gamma\tau + 8) \exp(-4c\gamma\tau));$$

$$\int \tau^2 P_5^{(0,\beta)}(\tau, \gamma) d\tau = -\frac{1}{99843767100c^3\gamma^3} \exp\left(-\frac{c\gamma\tau}{2}\right) \times (199687534200(c^2\gamma^2\tau^2 + 4c\gamma\tau + 8) - 36979173000(\beta + 6) \times (9c^2\gamma^2\tau^2 + 12c\gamma\tau + 8) \exp(-c\gamma\tau) + 7987501368(\beta^2 + 13\beta + 42)(25c^2\gamma^2\tau^2 + 20c\gamma\tau + 8) \exp(-2c\gamma\tau) - 970299000(\beta^3 + 21 \times \beta^2 + 146\beta + 336)(49c^2\gamma^2\tau^2 + 28c\gamma\tau + 8) \exp(-3c\gamma\tau) + 57066625(\beta^4 + 30\beta^3 + 335\beta^2 + 1650\beta + 3024)(81c^2\gamma^2\tau^2 + 36c\gamma\tau + 8) \exp(-4c\gamma\tau) - 12502359(\beta^5 + 40\beta^4 + 635\beta^3 + 5000 \times \beta^2 + 19524\beta + 30240)(121c^2\gamma^2\tau^2 + 44c\gamma\tau + 8) \exp(-5c\gamma\tau)).$$





Рис. 1.128. Вид неопределенного интеграла 2-ого рода от ортогональных функций Якоби 2-ого порядка: а)  $\gamma = 2, \beta \in [0; 5]$ ; б)  $\gamma \in (1; 3, 5), \beta = 1$

$$[1.129] \quad \int \tau^3 P_k^{(0,\beta)}(\tau, \gamma) d\tau = - \sum_{s=0}^k \binom{k}{s} \binom{k+s+\beta}{s} \times \\ \times (-1)^s \exp(-2s+1)c\gamma\tau/2) \left( \frac{2\tau^3}{c\gamma(2s+1)} + \right. \\ \left. + \frac{12\tau^2}{c^2\gamma^2(2s+1)^2} + \frac{48\tau}{c^3\gamma^3(2s+1)^3} + \frac{96}{c^4\gamma^4(2s+1)^4} \right).$$

Частные случаи для неопределенного интеграла 3-ого рода от функций 0-5 порядков:

$$\int \tau^3 P_0^{(0,\beta)}(\tau, \gamma) d\tau = - \frac{2}{c^4\gamma^4} \exp\left(-\frac{c\gamma\tau}{2}\right) (48 + 24c\gamma\tau + \\ + 6c^2\gamma^2\tau^2 + c^3\gamma^3\tau^3); \\ \int \tau^3 P_1^{(0,\beta)}(\tau, \gamma) d\tau = - \frac{2}{27c^4\gamma^4} \exp\left(-\frac{c\gamma\tau}{2}\right) (54(c^3\gamma^3\tau^3 + \\ + 6c^2\gamma^2\tau^2 + 24c\gamma\tau + 48) - 2(\beta+2)(9c^3\gamma^3\tau^3 + 18c^2\gamma^2\tau^2 + \\ + 24c\gamma\tau + 16) \exp(-c\gamma\tau)); \\ \int \tau^3 P_2^{(0,\beta)}(\tau, \gamma) d\tau = - \frac{1}{16875c^4\gamma^4} \exp\left(-\frac{c\gamma\tau}{2}\right) \times \\ \times (33750(c^3\gamma^3\tau^3 + 6c^2\gamma^2\tau^2 + 24c\gamma\tau + 48) - 2500(\beta+3) \times \\ \times (9c^3\gamma^3\tau^3 + 18c^2\gamma^2\tau^2 + 24c\gamma\tau + 16) \exp(-c\gamma\tau) + 27(\beta^2 + \\ + 7\beta + 12)(125c^3\gamma^3\tau^3 + 150c^2\gamma^2\tau^2 + 120c\gamma\tau + 48) \exp(-2c\gamma\tau)); \\ \int \tau^3 P_3^{(0,\beta)}(\tau, \gamma) d\tau = - \frac{1}{13505625c^4\gamma^4} \exp\left(-\frac{c\gamma\tau}{2}\right) \times$$

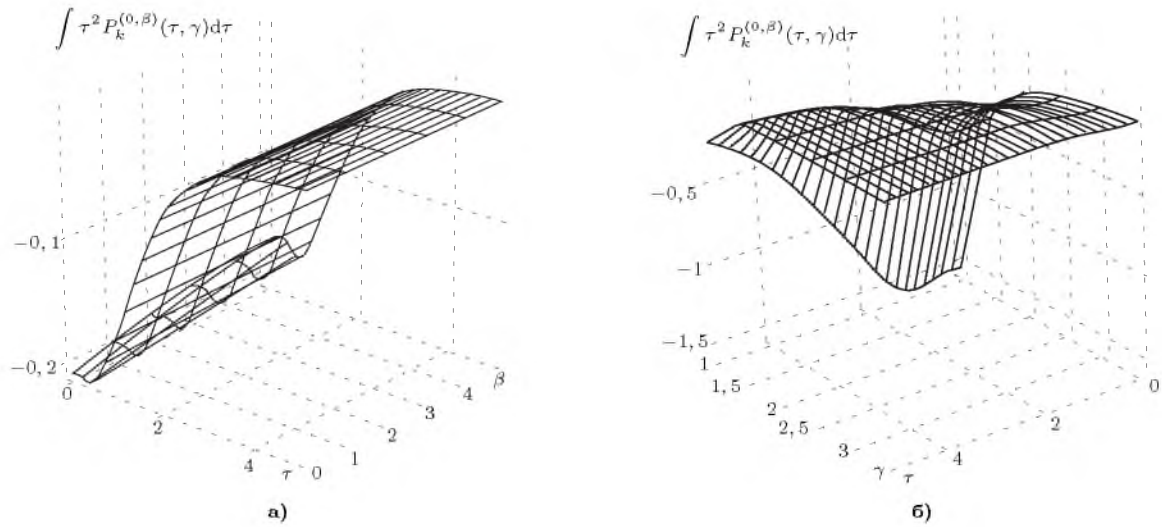
$$\times (27011250(c^3\gamma^3\tau^3 + 6c^2\gamma^2\tau^2 + 24c\gamma\tau + 48) - 3001250(\beta+4) \times \\ \times (9c^3\gamma^3\tau^3 + 18c^2\gamma^2\tau^2 + 24c\gamma\tau + 16) \exp(-c\gamma\tau) + 64827(\beta^2 + \\ + 9\beta + 20)(125c^3\gamma^3\tau^3 + 150c^2\gamma^2\tau^2 + 120c\gamma\tau + 48) \exp(-2c\gamma\tau) - \\ - 1875(\beta^3 + 15\beta^2 + 74\beta + 120)(343c^3\gamma^3\tau^3 + 294c^2\gamma^2\tau^2 + 168c\gamma\tau + \\ + 48) \exp(-3c\gamma\tau)); \\ \int \tau^3 P_4^{(0,\beta)}(\tau, \gamma) d\tau = - \frac{1}{39382402500c^4\gamma^4} \exp\left(-\frac{c\gamma\tau}{2}\right) \times \\ \times (78764805000(c^3\gamma^3\tau^3 + 6c^2\gamma^2\tau^2 + 24c\gamma\tau + 48) - 11668860000 \times \\ \times (\beta+5)(9c^3\gamma^3\tau^3 + 18c^2\gamma^2\tau^2 + 24c\gamma\tau + 16) \exp(-c\gamma\tau) + \\ + 378071064(\beta^2 + 11\beta + 30)(125c^3\gamma^3\tau^3 + 150c^2\gamma^2\tau^2 + \\ + 120c\gamma\tau + 48) \exp(-2c\gamma\tau) - 21870000(\beta^3 + 18\beta^2 + 107\beta + 210) \times \\ \times (343c^3\gamma^3\tau^3 + 294c^2\gamma^2\tau^2 + 168c\gamma\tau + 48) \exp(-3c\gamma\tau) + \\ + 1500625(\beta^4 + 26\beta^3 + 251\beta^2 + 1066\beta + 1680)(243c^3\gamma^3\tau^3 + \\ + 162c^2\gamma^2\tau^2 + 72c\gamma\tau + 16) \exp(-4c\gamma\tau)); \\ \int \tau^3 P_5^{(0,\beta)}(\tau, \gamma) d\tau = - \frac{1}{9609962583375c^4\gamma^4} \exp\left(-\frac{c\gamma\tau}{2}\right) \times \\ \times (19219925166750(c^3\gamma^3\tau^3 + 6c^2\gamma^2\tau^2 + 24c\gamma\tau + 48) - \\ - 3559245401250(\beta+6)(9c^3\gamma^3\tau^3 + 18c^2\gamma^2\tau^2 + 24c\gamma\tau + 16) \times \\ \times \exp(-c\gamma\tau) + 307518802668(\beta^2 + 13\beta + 42)(125c^3\gamma^3\tau^3 + \\ + 150c^2\gamma^2\tau^2 + 120c\gamma\tau + 48) \exp(-2c\gamma\tau) - 80049667500(\beta^3 + 21 \times \\ \times \beta^2 + 146\beta + 336)(343c^3\gamma^3\tau^3 + 294c^2\gamma^2\tau^2 + 168c\gamma\tau + 48) \times \\ \times \exp(-3c\gamma\tau) + 43941301250(\beta^4 + 30\beta^3 + 335\beta^2 + 1650\beta + \\ + 3024)(243c^3\gamma^3\tau^3 + 162c^2\gamma^2\tau^2 + 72c\gamma\tau + 16) \exp(-4c\gamma\tau) - \\ - 1312746750(\beta^5 + 40\beta^4 + 635\beta^3 + 5000\beta^2 + 19524\beta + \\ + 30240)(1331c^3\gamma^3\tau^3 + 726c^2\gamma^2\tau^2 + 264c\gamma\tau + 48) \exp(-5c\gamma\tau)).$$



Рис. 1.129. Вид неопределенного интеграла 3-го рода от ортогональных функций Якоби 2-го порядка: а)  $\gamma = 2, \beta \in [0; 5]$ ; б)  $\gamma \in (1; 3, 5], \beta = 1$

$$[1.130] \quad \int \tau^n P_k^{(0, \beta)}(\tau, \gamma) d\tau = - \sum_{s=0}^k \binom{k}{s} \binom{k+s+\beta}{s} \times \\ \times (-1)^s \exp(-(2s+1)c\gamma\tau/2) \times \\ \times \sum_{j=0}^n \frac{n! \tau^{n-j}}{(n-j)! (c\gamma(2s+1)/2)^{j+1}}.$$

Частные случаи для неопределенного интеграла n-го рода от функций 0-5 порядков:

$$\int \tau^n P_0^{(0, \beta)}(\tau, \gamma) d\tau = - \frac{2n!}{\gamma} \exp(-c\gamma\tau/2) \times \\ \times \sum_{j=0}^n \left( \frac{2}{c\gamma/2} \right)^j \frac{\tau^{n-j}}{(n-j)!};$$

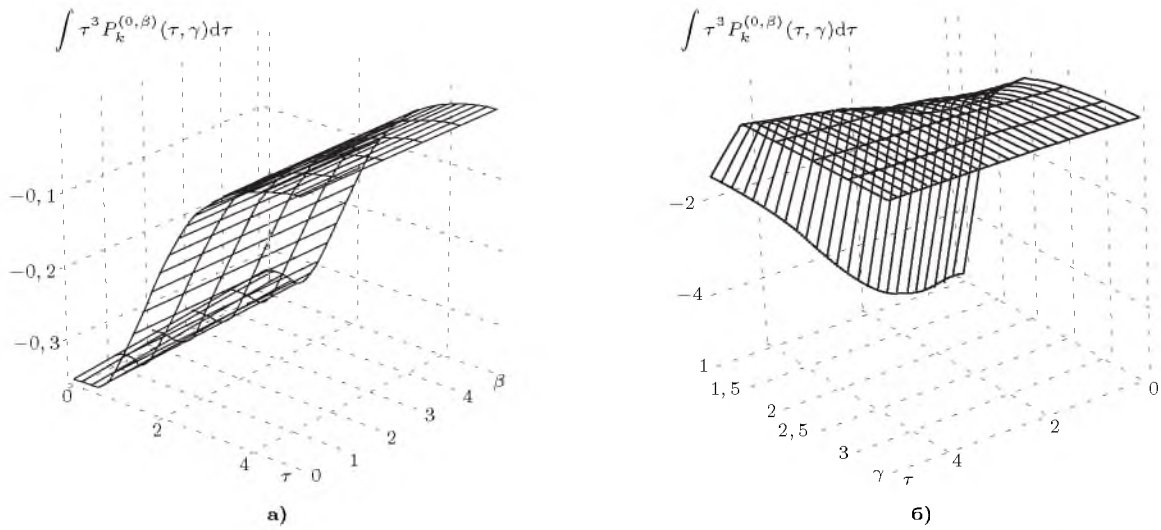
$$\int \tau^n P_1^{(0, \beta)}(\tau, \gamma) d\tau = - \exp(-c\gamma\tau/2) \times \\ \times \left( n! \sum_{j=0}^n \frac{\tau^{n-j}}{(n-j)! (c\gamma/2)^{j+1}} - \right. \\ \left. - (\beta+2)n! \exp(-\gamma\tau) \sum_{j=0}^n \frac{\tau^{n-j}}{(n-j)! (3c\gamma/2)^{j+1}} \right);$$

$$\int \tau^n P_2^{(0, \beta)}(\tau, \gamma) d\tau = - \exp(-c\gamma\tau/2) \times \\ \times \left( n! \sum_{j=0}^n \frac{\tau^{n-j}}{(n-j)! (c\gamma/2)^{j+1}} - \right. \\ \left. - 2(\beta+3)n! \exp(-c\gamma\tau) \sum_{j=0}^n \frac{\tau^{n-j}}{(n-j)! (3c\gamma/2)^{j+1}} + \right. \\ \left. + (\beta+4)n! \exp(-2c\gamma\tau) \sum_{j=0}^n \frac{\tau^{n-j}}{(n-j)! (5c\gamma/2)^{j+1}} \right);$$

$$\int \tau^n P_3^{(0, \beta)}(\tau, \gamma) d\tau = - \exp(-c\gamma\tau/2) \times$$

$$\times \left( n! \sum_{j=0}^n \frac{\tau^{n-j}}{(n-j)! (c\gamma/2)^{j+1}} - \right. \\ \left. - 3(\beta+4)n! \exp(-c\gamma\tau) \sum_{j=0}^n \frac{\tau^{n-j}}{(n-j)! (3c\gamma/2)^{j+1}} + \right. \\ \left. + 3 \binom{\beta+5}{2} n! \exp(-2c\gamma\tau) \sum_{j=0}^n \frac{\tau^{n-j}}{(n-j)! (5c\gamma/2)^{j+1}} - \right. \\ \left. - (\beta+6)n! \exp(-3c\gamma\tau) \sum_{j=0}^n \frac{\tau^{n-j}}{(n-j)! (7c\gamma/2)^{j+1}} \right);$$

$$\int \tau^n P_4^{(0, \beta)}(\tau, \gamma) d\tau = - \exp(-c\gamma\tau/2) \times \\ \times \left( n! \sum_{j=0}^n \frac{\tau^{n-j}}{(n-j)! (c\gamma/2)^{j+1}} - \right. \\ \left. - 4(\beta+5)n! \exp(-c\gamma\tau) \sum_{j=0}^n \frac{\tau^{n-j}}{(n-j)! (3c\gamma/2)^{j+1}} + \right. \\ \left. + 6 \binom{\beta+6}{2} n! \exp(-2c\gamma\tau) \sum_{j=0}^n \frac{\tau^{n-j}}{(n-j)! (5c\gamma/2)^{j+1}} - \right. \\ \left. - 4 \binom{\beta+7}{3} n! \exp(-3c\gamma\tau) \sum_{j=0}^n \frac{\tau^{n-j}}{(n-j)! (7c\gamma/2)^{j+1}} + \right. \\ \left. + (\beta+8)n! \exp(-4c\gamma\tau) \sum_{j=0}^n \frac{\tau^{n-j}}{(n-j)! (9c\gamma/2)^{j+1}} \right);$$

$$\int \tau^n P_5^{(0, \beta)}(\tau, \gamma) d\tau = - \exp(-c\gamma\tau/2) \times \\ \times \left( n! \sum_{j=0}^n \frac{\tau^{n-j}}{(n-j)! (c\gamma/2)^{j+1}} - \right. \\ \left. - 5(\beta+6)n! \exp(-c\gamma\tau) \sum_{j=0}^n \frac{\tau^{n-j}}{(n-j)! (3c\gamma/2)^{j+1}} + \right. \\ \left. + 10 \binom{\beta+7}{2} n! \exp(-2c\gamma\tau) \sum_{j=0}^n \frac{\tau^{n-j}}{(n-j)! (5c\gamma/2)^{j+1}} - \right.$$

$$\begin{aligned}
 & - 10 \binom{\beta+8}{3} n! \exp(-3c\gamma\tau) \sum_{j=0}^n \frac{\tau^{n-j}}{(n-j)! (7c\gamma/2)^{j+1}} + \\
 & + 5 \binom{\beta+9}{4} n! \exp(-4c\gamma\tau) \sum_{j=0}^n \frac{\tau^{n-j}}{(n-j)! (9c\gamma/2)^{j+1}} -
 \end{aligned}
 \left|
 \begin{aligned}
 & - \binom{\beta+10}{5} n! \exp(-5c\gamma\tau) \sum_{j=0}^n \frac{\tau^{n-j}}{(n-j)! (11c\gamma/2)^{j+1}} \right).
 \end{aligned}$$



Рис. 1.130. Вид неопределенного интеграла n-ого рода от ортогональных функций Якоби 2-ого порядка: а)  $n = 0.5, \gamma = 2, \beta \in [0; 5]$ ; б)  $n = 0.5, \gamma \in (1; 3, 5], \beta = 1$



## Глава 2

# Основные и расширенные свойства во временной области

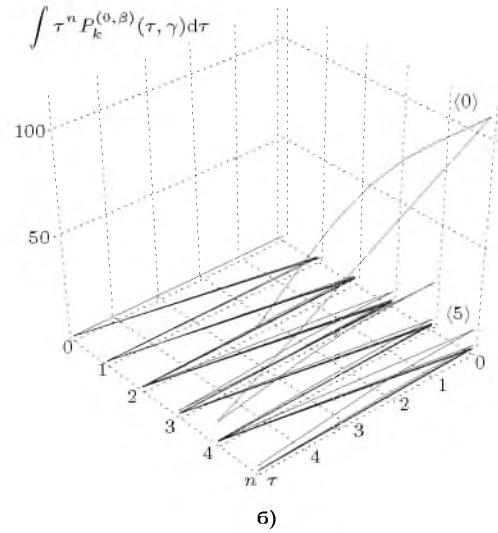
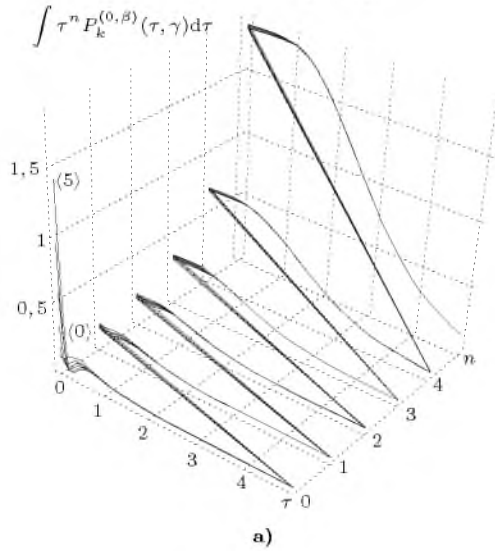
**Определение.**

Для ортогональных функций, определенных в Главе 1, определены основные свойства [13].

Вид функций $\psi_k(\tau, \gamma)$	Норма $\ \psi_k\ ^2$	Вес $\mu^{\{\psi_k(\tau, \gamma)\}}(\tau, \gamma)$	Значение в «нуле» $\psi_k(0, \gamma)$
$P_k^{(\alpha, 0)}(\tau, \gamma)$	$\frac{1}{c\gamma(2k + \alpha + 1)}$	1	$(-1)^k$
$P_k^{(0, \beta)}(\tau, \gamma)$	$\frac{1}{c\gamma(2k + \beta + 1)}$	$(1 - \exp(-c\gamma\tau))^\beta$	$(-1)^k \binom{k + \beta}{k}$
$L_k^{(\alpha)}(\tau, \gamma)$	$\frac{(k + \alpha)!}{k! \gamma^{\alpha+1}}$	$\tau^\alpha$	$\binom{k + \alpha}{k}$

и выявлено расширенное свойство [5]

$$\int_0^\infty \frac{\partial \psi_k(\tau, \gamma)}{\partial \tau} d\tau = -\psi_k(0, \gamma).$$

Таблица 2.1. Основные и расширенные свойства во временной области

Вид многочлена	Весовая функция	Значение в "нуле"	Интегральная характеристика
$\psi_k(\tau, \gamma)$	$\mu^{\{\psi_k(\tau, \gamma)\}}$	$\psi_k(0, \gamma)$	$\int_0^{\infty} \frac{\partial \psi_k(\tau, \gamma)}{\partial \tau} d\tau$
$L_k(\tau, \gamma)$	1	1	-1
$L_k^{(1)}(\tau, \gamma)$	$\tau$	$k+1$	$-k-1$
$L_k^{(2)}(\tau, \gamma)$	$\tau^2$	$\frac{(k+1)(k+2)}{2}$	$-\frac{(k+1)(k+2)}{2}$
$L_k^{(\alpha)}(\tau, \gamma)$	$\tau^\alpha$	$\binom{k+\alpha}{\alpha}$	$-\binom{k+\alpha}{\alpha}$
$P_k^{(-1/2,0)}(\tau, \gamma)$	1	$(-1)^k$	$(-1)^{k+1}$
$Leg_k(\tau, \gamma)$	1	$(-1)^k$	$(-1)^{k+1}$
$P_k^{(1/2,0)}(\tau, \gamma)$	1	$(-1)^k$	$(-1)^{k+1}$
$P_k^{(1,0)}(\tau, \gamma)$	1	$(-1)^k$	$(-1)^{k+1}$
$P_k^{(2,0)}(\tau, \gamma)$	1	$(-1)^k$	$(-1)^{k+1}$
$P_k^{(\alpha,0)}(\tau, \gamma)$	1	$(-1)^k$	$(-1)^{k+1}$
$P_k^{(0,1)}(\tau, \gamma)$	$1 - \exp(-c\gamma\tau)$	$(-1)^k(k+1)$	$(-1)^{k+1}(k+1)$
$P_k^{(0,2)}(\tau, \gamma)$	$(1 - \exp(-c\gamma\tau))^2$	$(-1)^k \frac{(k+1)(k+2)}{2}$	$(-1)^{k+1} \frac{(k+1)(k+2)}{2}$
$P_k^{(0,\beta)}(\tau, \gamma)$	$(1 - \exp(-c\gamma\tau))^\beta$	$(-1)^k \binom{k+\beta}{\beta}$	$(-1)^{k+1} \binom{k+\beta}{\beta}$

## Глава 3

# Основные и расширенные соотношения ортогональности во временной области

**Определение.**

Основное соотношение ортогональности имеет значения только по главной диагонали

$$\int_0^{\infty} \psi_k(\tau, \gamma) \psi_\nu(\tau, \gamma) \mu^{\{\psi_\nu(\tau, \gamma)\}}(\tau, \gamma) d\tau = g_{k,\nu}(\gamma),$$

$$G(\gamma) = \text{diag} \{g_{0,0}(\gamma), g_{1,1}(\gamma), \dots, g_{K,K}(\gamma)\}.$$

Значения диагональных элементов матрицы  $g_{k,\nu}(\gamma)$  приведены в Главе 1.

В отличие от основного соотношения в расширенном соотношении ортогональности [5]

$$\int_0^{\infty} \vartheta_k(\tau, \gamma) \psi_\nu(\tau, \gamma) \mu^{\{\psi_\nu(\tau, \gamma)\}}(\tau, \gamma) d\tau = h_{k,\nu}(\gamma) \quad (k = 0..K, \nu = 0..K)$$

элементы располагаются по нескольким смежным диагоналям, например,

$$H(\gamma) = \begin{pmatrix} h_{0,0}(\gamma) & h_{1,0}(\gamma) & 0 & 0 & \dots & 0 \\ h_{0,1}(\gamma) & h_{1,1}(\gamma) & h_{2,1}(\gamma) & 0 & \dots & 0 \\ 0 & h_{1,2}(\gamma) & h_{2,2}(\gamma) & h_{3,2}(\gamma) & \dots & 0 \\ 0 & 0 & h_{2,3}(\gamma) & h_{3,3}(\gamma) & \dots & \vdots \\ \vdots & \vdots & \vdots & \vdots & \ddots & h_{K-1,K}(\gamma) \\ 0 & 0 & 0 & \dots & h_{K,K-1}(\gamma) & h_{K,K}(\gamma) \end{pmatrix}.$$

### 3.1 Основные соотношения ортогональности

$$[3.1] \int_0^{\infty} L_s(\tau, \gamma) L_k(\tau, \gamma) d\tau = \begin{cases} \frac{1}{\gamma}, & \text{если } k = s; \\ 0, & \text{иначе.} \end{cases}$$

Матрица значений при  $k = 0..5; s = 0..5$ :

$$\mathcal{M}_{[3.1]} = \frac{1}{\gamma} \begin{pmatrix} 1 & 0 & 0 & 0 & 0 & 0 \\ 0 & 1 & 0 & 0 & 0 & 0 \\ 0 & 0 & 1 & 0 & 0 & 0 \\ 0 & 0 & 0 & 1 & 0 & 0 \\ 0 & 0 & 0 & 0 & 1 & 0 \\ 0 & 0 & 0 & 0 & 0 & 1 \end{pmatrix}.$$



Рис. 3.1. Графическое представление соотношения [3.1] при  $k = 0.5, s = 0.5; \gamma = 1$

$$[3.2] \int_0^{\infty} L_s^{(1)}(\tau, \gamma) L_k^{(1)}(\tau, \gamma) \mu^{\{L_s^{(1)}(\tau, \gamma)\}}(\tau, \gamma) d\tau = \begin{cases} \frac{k+1}{\gamma^2}, & \text{если } k = s; \\ 0, & \text{иначе.} \end{cases}$$

Матрица значений при  $k = 0.5; s = 0.5$ :

$$\mathcal{M}_{[3.2]} = \frac{1}{\gamma^2} \begin{pmatrix} 1 & 0 & 0 & 0 & 0 & 0 \\ 0 & 2 & 0 & 0 & 0 & 0 \\ 0 & 0 & 3 & 0 & 0 & 0 \\ 0 & 0 & 0 & 4 & 0 & 0 \\ 0 & 0 & 0 & 0 & 5 & 0 \\ 0 & 0 & 0 & 0 & 0 & 6 \end{pmatrix}.$$

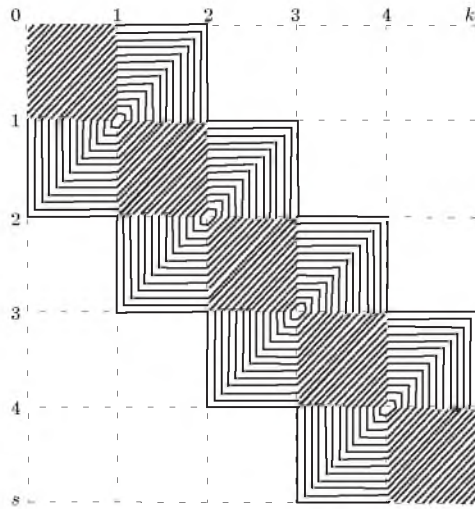

Рис. 3.2. Графическое представление соотношения [3.2] при  $k = 0.5, s = 0.5; \gamma = 1$

$$[3.3] \int_0^{\infty} L_s^{(2)}(\tau, \gamma) L_k^{(2)}(\tau, \gamma) \mu^{\{L_s^{(2)}(\tau, \gamma)\}}(\tau, \gamma) d\tau = \begin{cases} \frac{(k+1)(k+2)}{\gamma^3}, & \text{если } k = s; \\ 0, & \text{иначе.} \end{cases}$$

Матрица значений при  $k = 0.5; s = 0.5$ :

$$\mathcal{M}_{[3.3]} = \frac{1}{\gamma^3} \begin{pmatrix} 2 & 0 & 0 & 0 & 0 & 0 \\ 0 & 6 & 0 & 0 & 0 & 0 \\ 0 & 0 & 12 & 0 & 0 & 0 \\ 0 & 0 & 0 & 20 & 0 & 0 \\ 0 & 0 & 0 & 0 & 30 & 0 \\ 0 & 0 & 0 & 0 & 0 & 42 \end{pmatrix}.$$

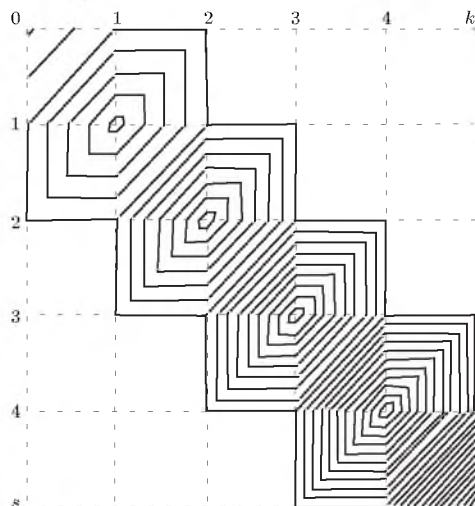

Рис. 3.3. Графическое представление соотношения [3.3] при  $k = 0.5, s = 0.5; \gamma = 1$

$$[3.4] \int_0^{\infty} L_s^{(\alpha)}(\tau, \gamma) L_k^{(\alpha)}(\tau, \gamma) \mu^{\{L_s^{(\alpha)}(\tau, \gamma)\}}(\tau, \gamma) d\tau = \begin{cases} \frac{(k+\alpha)!}{k! \gamma^{\alpha+1}}, & \text{если } k = s; \\ 0, & \text{иначе.} \end{cases}$$

Матрица значений при  $k = 0.5; s = 0.5$ :

$$\mathcal{M}_{[3.4]} = \frac{1}{\gamma^{\alpha+1}} \times \begin{pmatrix} \alpha! & 0 & 0 & 0 & 0 & 0 \\ 0 & (\alpha+1)! & 0 & 0 & 0 & 0 \\ 0 & 0 & (\alpha+2)! & 0 & 0 & 0 \\ 0 & 0 & 0 & (\alpha+3)! & 0 & 0 \\ 0 & 0 & 0 & 0 & (\alpha+4)! & 0 \\ 0 & 0 & 0 & 0 & 0 & (\alpha+5)! \end{pmatrix}.$$

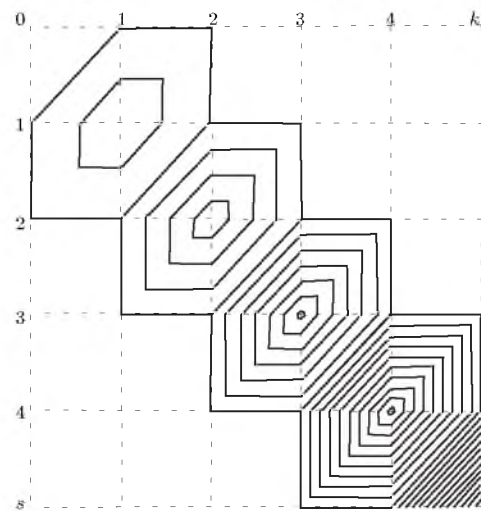



Рис. 3.4. Графическое представление соотношения [3.4] при  $k = 0.5$  и  $k = s$ : а)  $\gamma = 1, \alpha \in [0; 5]$ ; б)  $\gamma \in [1; 6], \alpha = 1$

$$[3.5] \int_0^\infty P_s^{(-1/2,0)}(\tau, \gamma) P_k^{(-1/2,0)}(\tau, \gamma) d\tau = \begin{cases} \frac{1}{\gamma(4k+1)}, & \text{если } k = s; \\ 0, & \text{иначе.} \end{cases}$$

Матрица значений при  $k = 0.5; s = 0.5$ :

$$\mathcal{M}_{[3.5]} = \frac{1}{\gamma} \begin{pmatrix} 1 & 0 & 0 & 0 & 0 & 0 \\ 0 & 1/5 & 0 & 0 & 0 & 0 \\ 0 & 0 & 1/9 & 0 & 0 & 0 \\ 0 & 0 & 0 & 1/13 & 0 & 0 \\ 0 & 0 & 0 & 0 & 1/17 & 0 \\ 0 & 0 & 0 & 0 & 0 & 1/21 \end{pmatrix},$$

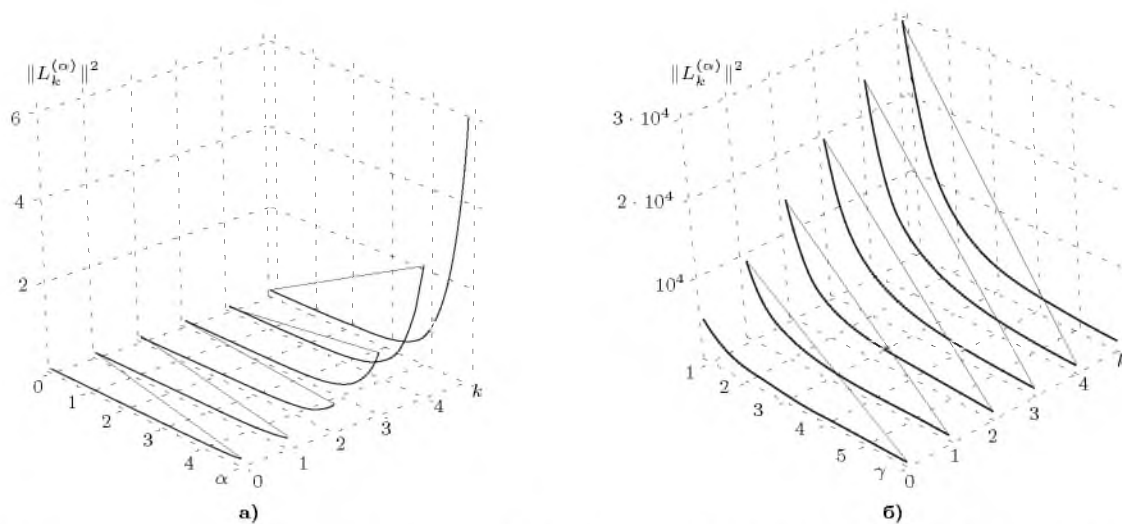

Рис. 3.5. Графическое представление соотношения [3.5] при  $k = 0.5, s = 0.5; \gamma = 1$

$$[3.6] \int_0^\infty Leg_s(\tau, \gamma) Leg_k(\tau, \gamma) d\tau = \begin{cases} \frac{1}{2\gamma(2k+1)}, & \text{если } k = s; \\ 0, & \text{иначе.} \end{cases}$$

Матрица значений при  $k = 0.5; s = 0.5$ :

$$\mathcal{M}_{[3.6]} = \frac{1}{2\gamma} \begin{pmatrix} 1 & 0 & 0 & 0 & 0 & 0 \\ 0 & 1/3 & 0 & 0 & 0 & 0 \\ 0 & 0 & 1/5 & 0 & 0 & 0 \\ 0 & 0 & 0 & 1/7 & 0 & 0 \\ 0 & 0 & 0 & 0 & 1/9 & 0 \\ 0 & 0 & 0 & 0 & 0 & 1/11 \end{pmatrix},$$

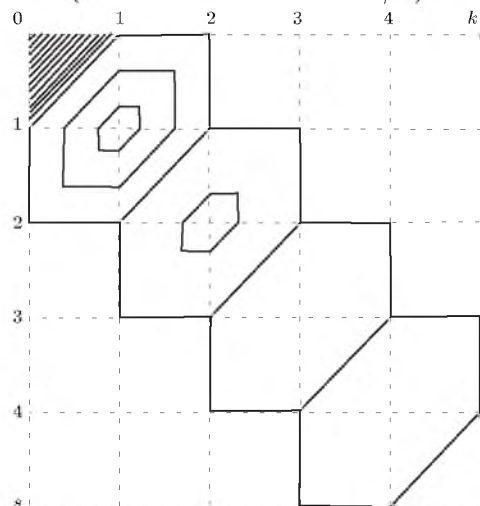

Рис. 3.6. Графическое представление соотношения [3.6] при  $k = 0.5, s = 0.5; \gamma = 1$

$$[3.7] \int_0^{\infty} P_s^{(1/2,0)}(\tau, \gamma) P_k^{(1/2,0)}(\tau, \gamma) d\tau = \begin{cases} \frac{1}{\gamma(4k+3)}, & \text{если } k = s; \\ 0, & \text{иначе.} \end{cases}$$

Матрица значений при  $k = 0..5; s = 0..5$ :

$$\mathcal{M}_{[3.7]} = \frac{1}{\gamma} \begin{pmatrix} 1/3 & 0 & 0 & 0 & 0 & 0 \\ 0 & 1/7 & 0 & 0 & 0 & 0 \\ 0 & 0 & 1/11 & 0 & 0 & 0 \\ 0 & 0 & 0 & 1/15 & 0 & 0 \\ 0 & 0 & 0 & 0 & 1/19 & 0 \\ 0 & 0 & 0 & 0 & 0 & 1/23 \end{pmatrix}.$$

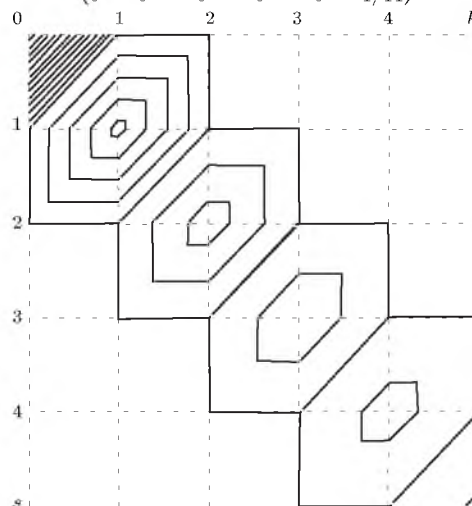

Рис. 3.7. Графическое представление соотношения [3.7] при  $k = 0.5, s = 0.5; \gamma = 1$

$$[3.8] \int_0^{\infty} P_s^{(1,0)}(\tau, \gamma) P_k^{(1,0)}(\tau, \gamma) d\tau = \begin{cases} \frac{1}{2\gamma(k+1)}, & \text{если } k = s; \\ 0, & \text{иначе.} \end{cases}$$

Матрица значений при  $k = 0.5; s = 0..5$ :

$$\mathcal{M}_{[3.8]} = \frac{1}{2\gamma} \begin{pmatrix} 1 & 0 & 0 & 0 & 0 & 0 \\ 0 & 1/2 & 0 & 0 & 0 & 0 \\ 0 & 0 & 1/3 & 0 & 0 & 0 \\ 0 & 0 & 0 & 1/4 & 0 & 0 \\ 0 & 0 & 0 & 0 & 1/5 & 0 \\ 0 & 0 & 0 & 0 & 0 & 1/6 \end{pmatrix}.$$

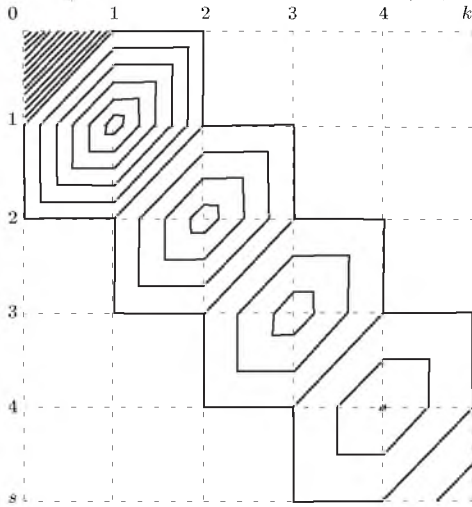

Рис. 3.8. Графическое представление соотношения [3.8] при  $k = 0.5, s = 0.5; \gamma = 1$

$$[3.9] \int_0^{\infty} P_s^{(2,0)}(\tau, \gamma) P_k^{(2,0)}(\tau, \gamma) d\tau = \begin{cases} \frac{1}{2\gamma(2k+3)}, & \text{если } k = s; \\ 0, & \text{иначе.} \end{cases}$$

Матрица значений при  $k = 0.5; s = 0..5$ :

$$\mathcal{M}_{[3.9]} = \frac{1}{2\gamma} \begin{pmatrix} 1/3 & 0 & 0 & 0 & 0 & 0 \\ 0 & 1/5 & 0 & 0 & 0 & 0 \\ 0 & 0 & 1/7 & 0 & 0 & 0 \\ 0 & 0 & 0 & 1/9 & 0 & 0 \\ 0 & 0 & 0 & 0 & 1/11 & 0 \\ 0 & 0 & 0 & 0 & 0 & 1/13 \end{pmatrix}.$$

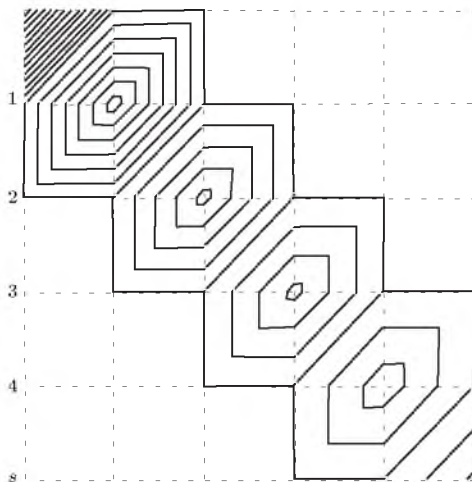

Рис. 3.9. Графическое представление соотношения [3.9] при  $k = 0.5, s = 0.5; \gamma = 1$

$$[3.10] \int_0^{\infty} P_s^{(\alpha,0)}(\tau, \gamma) P_k^{(\alpha,0)}(\tau, \gamma) d\tau = \begin{cases} \frac{1}{c\gamma(2k+\alpha+1)}, & \text{если } k = s; \\ 0, & \text{иначе.} \end{cases}$$

Матрица значений при  $k = 0.5; s = 0..5$ :

$$\mathcal{M}_{[3.10]} = \frac{1}{c\gamma} \times \begin{pmatrix} \frac{1}{(\alpha+1)} & 0 & 0 & 0 & 0 & 0 \\ 0 & \frac{1}{(\alpha+3)} & 0 & 0 & 0 & 0 \\ 0 & 0 & \frac{1}{(\alpha+5)} & 0 & 0 & 0 \\ 0 & 0 & 0 & \frac{1}{(\alpha+7)} & 0 & 0 \\ 0 & 0 & 0 & 0 & \frac{1}{(\alpha+9)} & 0 \\ 0 & 0 & 0 & 0 & 0 & \frac{1}{(\alpha+11)} \end{pmatrix}.$$

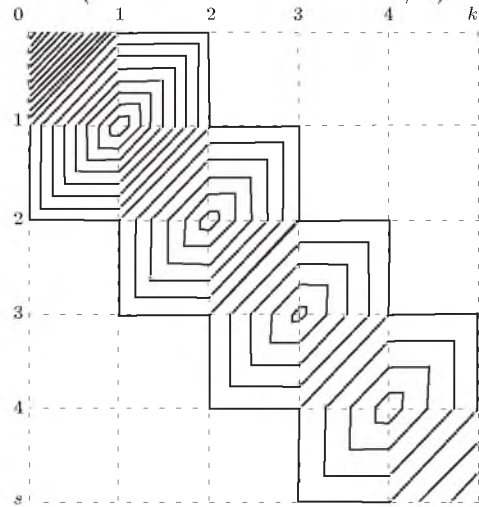

Рис. 3.10. Графическое представление соотношения [3.10] при  $k = 0.5$  и  $k = s$ : а)  $\gamma = 1$ ,  $c = 2$ ,  $\alpha \in [0; 5]$ ; б)  $\gamma \in [0, 5; 5, 5]$ ,  $c = 2$ ,  $\alpha = 1$

$$[3.11] \quad \int_0^\infty P_s^{(0,1)}(\tau, \gamma) P_k^{(0,1)}(\tau, \gamma) \mu^{\{P_s^{(0,1)}(\tau, \gamma)\}}(\tau, \gamma) d\tau = \begin{cases} \frac{1}{4\gamma(k+1)}, & \text{если } k = s; \\ 0, & \text{иначе.} \end{cases}$$

Матрица значений при  $k = 0.5; s = 0.5$ :

$$\mathcal{M}_{[3.11]} = \frac{1}{4\gamma} \begin{pmatrix} 1 & 0 & 0 & 0 & 0 & 0 \\ 0 & 1/2 & 0 & 0 & 0 & 0 \\ 0 & 0 & 1/3 & 0 & 0 & 0 \\ 0 & 0 & 0 & 1/4 & 0 & 0 \\ 0 & 0 & 0 & 0 & 1/5 & 0 \\ 0 & 0 & 0 & 0 & 0 & 1/6 \end{pmatrix}$$

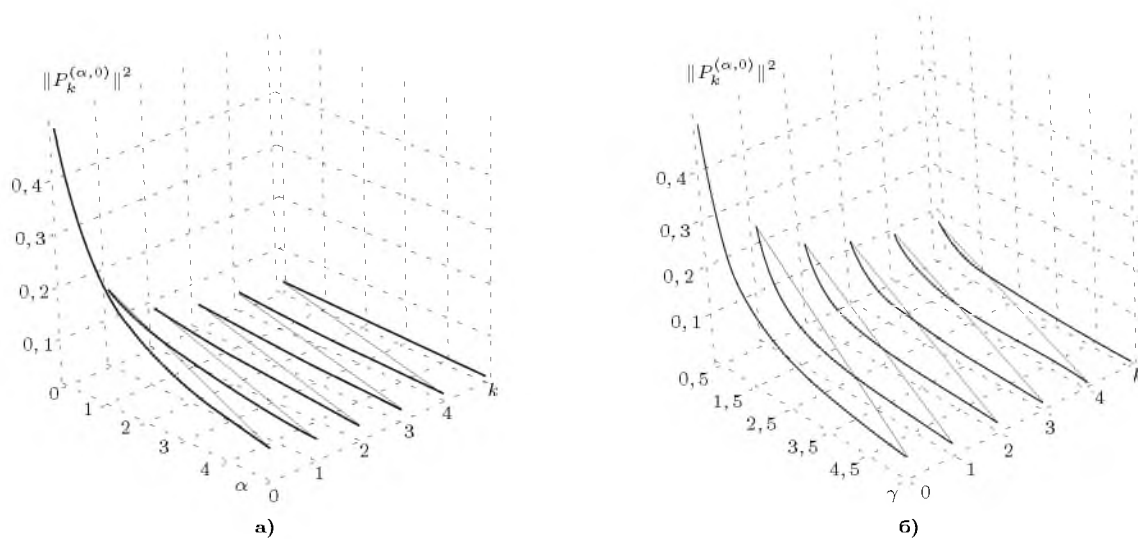

Рис. 3.11. Графическое представление соотношения [3.11] при  $k = 0.5, s = 0.5; \gamma = 1$

$$[3.12] \quad \int_0^\infty P_s^{(0,2)}(\tau, \gamma) P_k^{(0,2)}(\tau, \gamma) \mu^{\{P_s^{(0,2)}(\tau, \gamma)\}}(\tau, \gamma) d\tau = \begin{cases} \frac{1}{2\gamma(2k+3)}, & \text{если } k = s; \\ 0, & \text{иначе.} \end{cases}$$

Матрица значений при  $k = 0.5; s = 0.5$ :

$$\mathcal{M}_{[3.12]} = \frac{1}{2\gamma} \begin{pmatrix} 1/3 & 0 & 0 & 0 & 0 & 0 \\ 0 & 1/5 & 0 & 0 & 0 & 0 \\ 0 & 0 & 1/7 & 0 & 0 & 0 \\ 0 & 0 & 0 & 1/9 & 0 & 0 \\ 0 & 0 & 0 & 0 & 1/11 & 0 \\ 0 & 0 & 0 & 0 & 0 & 1/13 \end{pmatrix}$$

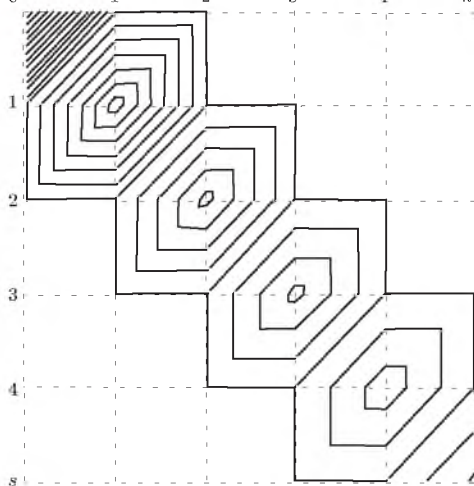

Рис. 3.12. Графическое представление соотношения [3.12] при  $k = 0.5, s = 0.5; \gamma = 1$

$$[3.13] \int_0^\infty P_s^{(0,\beta)}(\tau, \gamma) P_k^{(0,\beta)}(\tau, \gamma) \mu^{(P_s^{(0,\beta)}(\tau, \gamma))}(\tau, \gamma) d\tau = \begin{cases} \frac{1}{c\gamma(2k + \beta + 1)}, & \text{если } k = s; \\ 0, & \text{иначе.} \end{cases}$$

Матрица значений при  $k = 0.5; s = 0.5$ :

$$\mathcal{M}_{[3.13]} = \frac{1}{c\gamma} \times \begin{pmatrix} \frac{1}{(\beta+1)} & 0 & 0 & 0 & 0 & 0 \\ 0 & \frac{1}{(\beta+3)} & 0 & 0 & 0 & 0 \\ 0 & 0 & \frac{1}{(\beta+5)} & 0 & 0 & 0 \\ 0 & 0 & 0 & \frac{1}{(\beta+7)} & 0 & 0 \\ 0 & 0 & 0 & 0 & \frac{1}{(\beta+9)} & 0 \\ 0 & 0 & 0 & 0 & 0 & \frac{1}{(\beta+11)} \end{pmatrix}.$$

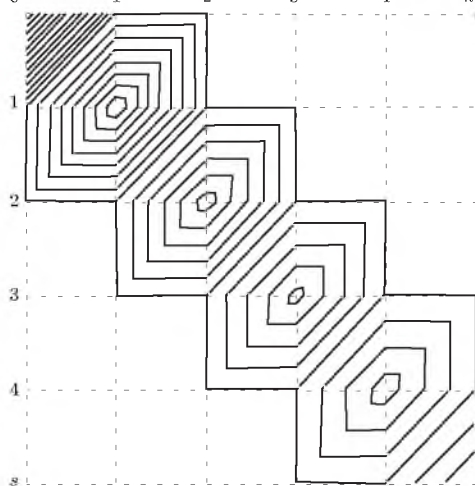

Рис. 3.13. Графическое представление соотношения [3.13] при  $k = 0.5$  и  $k = s$ : а)  $\gamma = 1, c = 2, \alpha \in [0; 5]$ ; б)  $\gamma \in [0, 5; 5, 5], c = 2, \alpha = 1$

### 3.2 Расширенные соотношения ортогональности

$$[3.14] \int_0^\infty L_s^{(1)}(\tau, \gamma) L_k(\tau, \gamma) \mu^{(L_s^{(1)}(\tau, \gamma))}(\tau, \gamma) d\tau = \begin{cases} \frac{k+1}{\gamma^2}, & \text{если } k = s; \\ \frac{k}{-\gamma^2}, & \text{если } k = s + 1; \\ 0, & \text{иначе.} \end{cases}$$

Матрица значений при  $k = 0.5; s = 0.5$ :

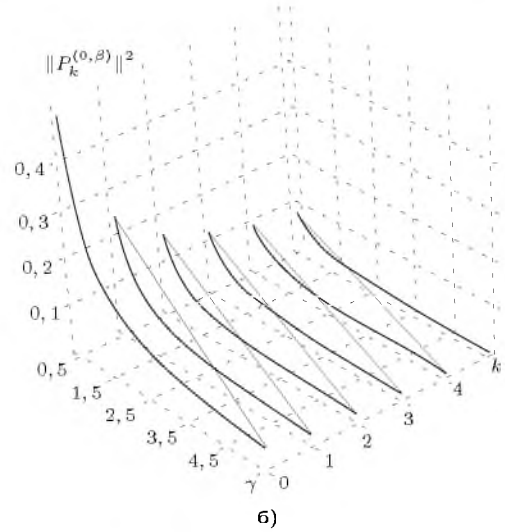
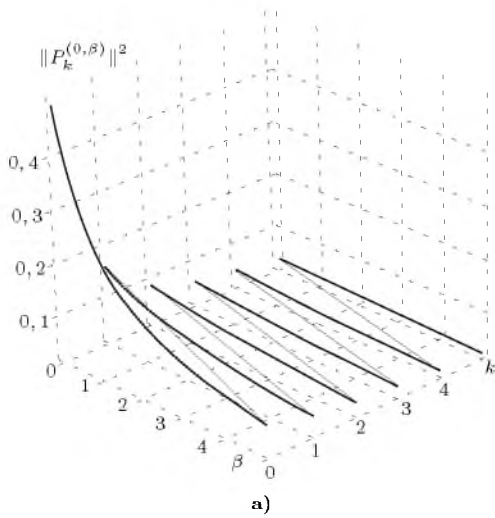
$$\mathcal{M}_{[3.14]} = \frac{1}{\gamma^2} \begin{pmatrix} 1 & -1 & 0 & 0 & 0 & 0 \\ 0 & 2 & -2 & 0 & 0 & 0 \\ 0 & 0 & 3 & -3 & 0 & 0 \\ 0 & 0 & 0 & 4 & -4 & 0 \\ 0 & 0 & 0 & 0 & 5 & -5 \\ 0 & 0 & 0 & 0 & 0 & 6 \end{pmatrix}.$$



Рис. 3.14. Графическое представление соотношения [3.14] при  $k = 0.5, s = 0.5; \gamma = 1$

$$[3.15] \int_0^\infty \tau L_s(\tau, \gamma) L_k(\tau, \gamma) d\tau = \begin{cases} -\frac{k+1}{\gamma^2}, & \text{если } k = s - 1; \\ \frac{2k+1}{\gamma^2}, & \text{если } k = s; \\ \frac{\gamma^k}{k}, & \text{если } k = s + 1; \\ -\frac{1}{\gamma^2}, & \text{если } k = s + 2; \\ 0, & \text{иначе.} \end{cases}$$

Матрица значений при  $k = 0..5; s = 0..5$ :

$$\mathcal{M}_{[3.15]} = \frac{1}{\gamma^2} \begin{pmatrix} 1 & -1 & 0 & 0 & 0 & 0 \\ -1 & 3 & -2 & 0 & 0 & 0 \\ 0 & -2 & 5 & -3 & 0 & 0 \\ 0 & 0 & -3 & 7 & -4 & 0 \\ 0 & 0 & 0 & -4 & 9 & -5 \\ 0 & 0 & 0 & 0 & -5 & 11 \end{pmatrix}$$

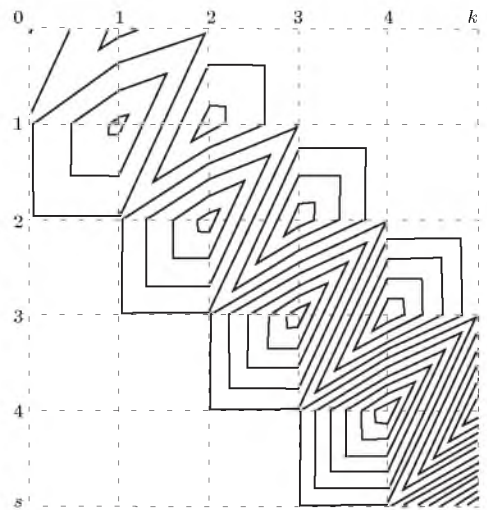

Рис. 3.15. Графическое представление соотношения [3.15] при  $k = 0..5, s = 0..5; \gamma = 1$

$$[3.16] \int_0^\infty L_s^{(2)}(\tau, \gamma) L_k^{(1)}(\tau, \gamma) \mu^{(L_s^{(2)})}(\tau, \gamma) d\tau = \begin{cases} \frac{(k+1)(k+2)}{\gamma^3}, & \text{если } k = s; \\ -\frac{k(k+1)}{\gamma^3}, & \text{если } k = s + 1; \\ 0, & \text{иначе.} \end{cases}$$

Матрица значений при  $k = 0..5; s = 0..5$ :

$$\mathcal{M}_{[3.16]} = \frac{1}{\gamma^3} \begin{pmatrix} 2 & -2 & 0 & 0 & 0 & 0 \\ 0 & 6 & -6 & 0 & 0 & 0 \\ 0 & 0 & 12 & -12 & 0 & 0 \\ 0 & 0 & 0 & 20 & -20 & 0 \\ 0 & 0 & 0 & 0 & 30 & -30 \\ 0 & 0 & 0 & 0 & 0 & 42 \end{pmatrix}$$

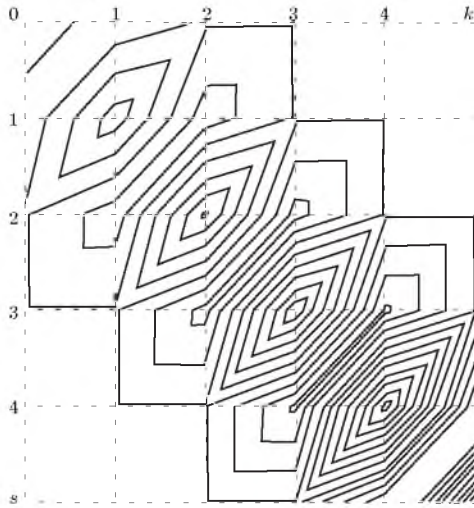

Рис. 3.16. Графическое представление соотношения [3.16] при  $k = 0..5, s = 0..5; \gamma = 1$

$$[3.17] \int_0^\infty \tau L_s^{(1)}(\tau, \gamma) L_k(\tau, \gamma) \mu^{(L_s^{(1)})}(\tau, \gamma) d\tau = \begin{cases} -\frac{(k+1)(k+2)}{\gamma^3}, & \text{если } k = s - 1; \\ \frac{(3k+2)(k+1)}{\gamma^3}, & \text{если } k = s; \\ -\frac{(3k+1)k}{\gamma^3}, & \text{если } k = s + 1; \\ \frac{k(k-1)}{\gamma^3}, & \text{если } k = s + 2; \\ 0, & \text{иначе.} \end{cases}$$

Матрица значений при  $k = 0..5; s = 0..5$ :

$$\mathcal{M}_{[3.17]} = \frac{1}{\gamma^3} \begin{pmatrix} 2 & -4 & 2 & 0 & 0 & 0 \\ -2 & 10 & -14 & 6 & 0 & 0 \\ 0 & -6 & 24 & -30 & 0 & 0 \\ 0 & 0 & -12 & 44 & -52 & 0 \\ 0 & 0 & 0 & -20 & 70 & -80 \\ 0 & 0 & 0 & 0 & -30 & 102 \end{pmatrix}$$

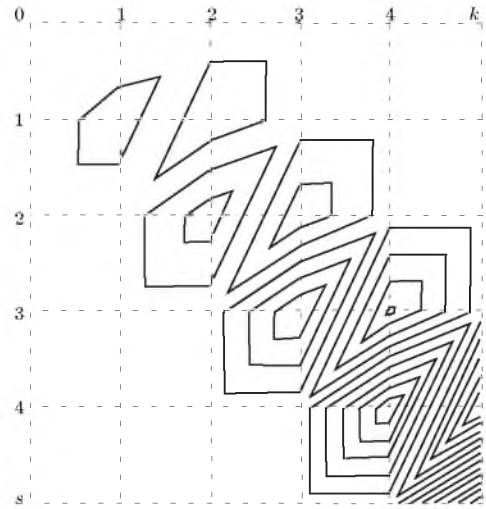

Рис. 3.17. Графическое представление соотношения [3.17] при  $k = 0.5, s = 0.5; \gamma = 1$

$$[3.18] \quad \int_0^{\infty} L_s(\tau, \gamma) \frac{\partial L_k(\tau, \gamma)}{\partial \tau} d\tau = \begin{cases} -1, & \text{если } k > s; \\ -\frac{1}{2}, & \text{если } k = s; \\ 0, & \text{иначе.} \end{cases}$$

Матрица значений при  $k = 0.5; s = 0.5$ :

$$\mathcal{M}_{[3.18]} = \begin{pmatrix} -1/2 & -1 & -1 & -1 & -1 & -1 \\ 0 & -1/2 & -1 & -1 & -1 & -1 \\ 0 & 0 & -1/2 & -1 & -1 & -1 \\ 0 & 0 & 0 & -1/2 & -1 & -1 \\ 0 & 0 & 0 & 0 & -1/2 & -1 \\ 0 & 0 & 0 & 0 & 0 & -1/2 \end{pmatrix}.$$

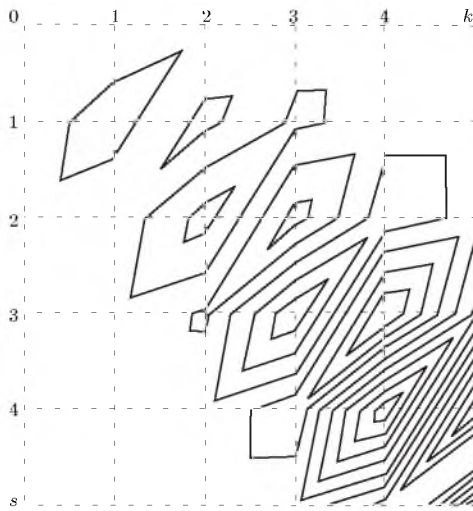

Рис. 3.18. Графическое представление соотношения [3.18] при  $k = 0.5, s = 0.5; \gamma = 1$

$$[3.19] \quad \int_0^{\infty} L_s(\tau, \gamma) \left( \int L_k(\tau, \gamma) d\tau \right) d\tau = \begin{cases} \frac{2}{\gamma^2}, & \text{если } k = s; \\ \frac{4(-1)^{k+s}}{\gamma^2}, & \text{если } k < s; \\ 0, & \text{иначе.} \end{cases}$$

Матрица значений при  $k = 0.5; s = 0.5$ :

$$\mathcal{M}_{[3.19]} = \frac{1}{\gamma^2} \begin{pmatrix} 2 & 0 & 0 & 0 & 0 & 0 \\ -4 & 2 & 0 & 0 & 0 & 0 \\ 4 & -4 & 2 & 0 & 0 & 0 \\ -4 & 4 & -4 & 2 & 0 & 0 \\ 4 & -4 & 4 & -4 & 2 & 0 \\ -4 & 4 & -4 & 4 & -4 & 2 \end{pmatrix}.$$

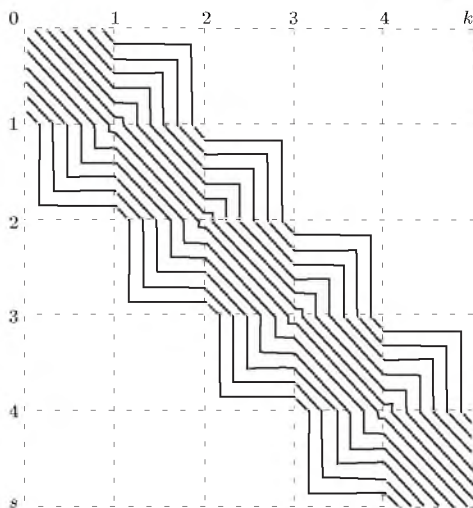

Рис. 3.19. Графическое представление соотношения [3.19] при  $k = 0.5, s = 0.5; \gamma = 1$

$$[3.20] \quad \int_0^{\infty} L_s(\tau, \gamma) \left( \int \tau L_k(\tau, \gamma) d\tau \right) d\tau = \begin{cases} -\frac{2k}{\gamma^3}, & \text{если } k = s + 1; \\ \frac{2(4k + 1)}{\gamma^3}, & \text{если } k = s; \\ -\frac{2(7k + 3)}{\gamma^3}, & \text{если } k = s - 1; \\ \frac{2(8k + 4)(-1)^{k+s}}{\gamma^3}, & k < s - 1 \\ 0, & \text{иначе.} \end{cases}$$

Матрица значений при  $k = 0.5; s = 0.5$ :

$$\mathcal{M}_{[3.20]} = \frac{1}{\gamma^3} \begin{pmatrix} 2 & -2 & 0 & 0 & 0 & 0 \\ -6 & 10 & -4 & 0 & 0 & 0 \\ 8 & -20 & 18 & -6 & 0 & 0 \\ -8 & 24 & -34 & 26 & -8 & 0 \\ 8 & -24 & 40 & -48 & 34 & -10 \\ -8 & 24 & -40 & 56 & -62 & 42 \end{pmatrix}.$$

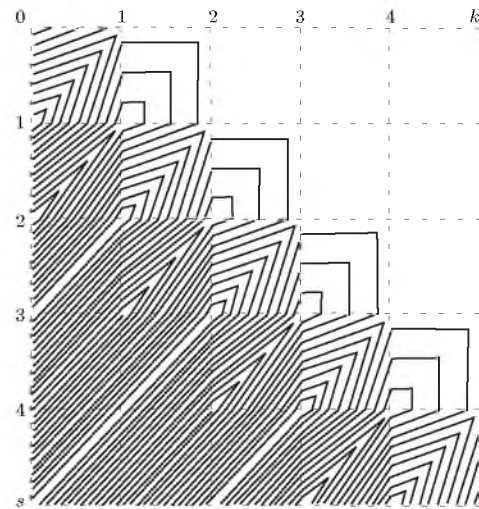

Рис. 3.20. Графическое представление соотношения [3.20] при  $k = 0..5, s = 0..5; \gamma = 1$

$$[3.21] \int_0^\infty L_s(\tau, \gamma) L_k^{(1)}(\tau, \gamma) d\tau = \begin{cases} \frac{1}{\gamma}, & \text{если } k \geq s; \\ 0, & \text{иначе.} \end{cases}$$

Матрица значений при  $k = 0..5; s = 0..5$ :

$$\mathcal{M}_{[3.21]} = \frac{1}{\gamma} \begin{pmatrix} 1 & 1 & 1 & 1 & 1 & 1 \\ 0 & 1 & 1 & 1 & 1 & 1 \\ 0 & 0 & 1 & 1 & 1 & 1 \\ 0 & 0 & 0 & 1 & 1 & 1 \\ 0 & 0 & 0 & 0 & 1 & 1 \\ 0 & 0 & 0 & 0 & 0 & 1 \end{pmatrix}$$

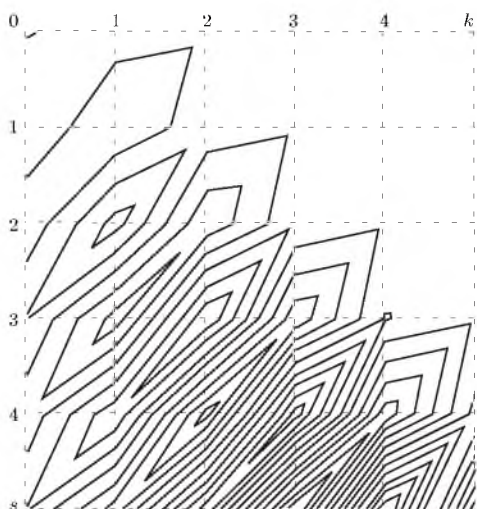

Рис. 3.21. Графическое представление соотношения [3.21] при  $k = 0..5, s = 0..5; \gamma = 1$

$$[3.22] \int_0^\infty \tau L_s(\tau, \gamma) L_k^{(1)}(\tau, \gamma) d\tau = \begin{cases} \frac{k+1}{\gamma^2}, & \text{если } k = s; \\ -\frac{k+1}{\gamma^2}, & \text{если } k = s-1; \\ 0, & \text{иначе.} \end{cases}$$

Матрица значений при  $k = 0..5; s = 0..5$ :

$$\mathcal{M}_{[3.22]} = \frac{1}{\gamma^2} \begin{pmatrix} 1 & 0 & 0 & 0 & 0 & 0 \\ -1 & 2 & 0 & 0 & 0 & 0 \\ 0 & -2 & 3 & 0 & 0 & 0 \\ 0 & 0 & -3 & 4 & 0 & 0 \\ 0 & 0 & 0 & -4 & 5 & 0 \\ 0 & 0 & 0 & 0 & -5 & 6 \end{pmatrix}$$

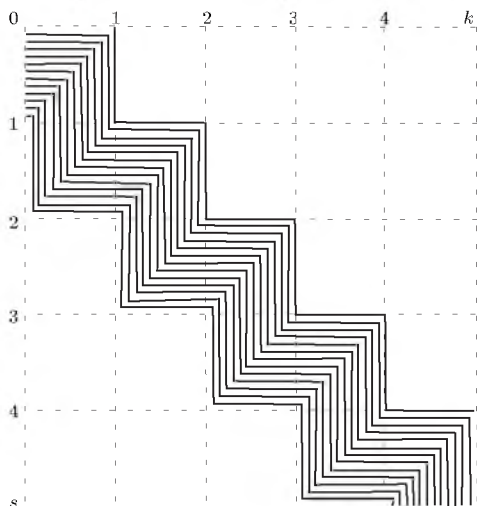

Рис. 3.22. Графическое представление соотношения [3.22] при  $k = 0..5, s = 0..5; \gamma = 1$

$$[3.23] \int_0^\infty L_s(\tau, \gamma) \frac{\partial L_k^{(1)}(\tau, \gamma)}{\partial \tau} d\tau = \begin{cases} -\frac{2(k-s)+1}{2}, & \text{если } k > s; \\ -\frac{1}{2}, & \text{если } k = s; \\ 0, & \text{иначе.} \end{cases}$$

Матрица значений при  $k = 0..5; s = 0..5$ :

$$\mathcal{M}_{[3.23]} = \begin{pmatrix} -1/2 & -3/2 & -5/2 & -7/2 & -9/2 & -11/2 \\ 0 & -1/2 & -3/2 & -5/2 & -7/2 & -9/2 \\ 0 & 0 & -1/2 & -3/2 & -5/2 & -7/2 \\ 0 & 0 & 0 & -1/2 & -3/2 & -5/2 \\ 0 & 0 & 0 & 0 & -1/2 & -5/2 \\ 0 & 0 & 0 & 0 & 0 & -1/2 \end{pmatrix}$$

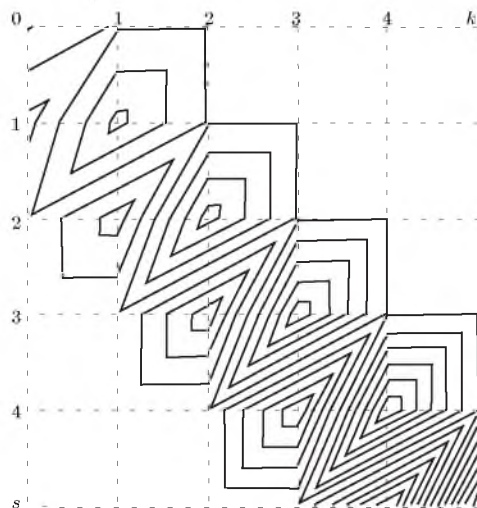

Рис. 3.23. Графическое представление соотношения [3.23] при  $k = 0.5, s = 0.5; \gamma = 1$



Рис. 3.24. Графическое представление соотношения [3.24] при  $k = 0.5, s = 0.5; \gamma = 1$

$$\begin{aligned}
 [3.24] \quad \int_0^\infty L_s(\tau, \gamma) L_k^{(2)}(\tau, \gamma) d\tau &= \\
 &= \begin{cases} \frac{k-s+1}{\gamma}, & \text{если } k > s; \\ \frac{1}{\gamma}, & \text{если } k = s; \\ 0, & \text{иначе.} \end{cases}
 \end{aligned}$$

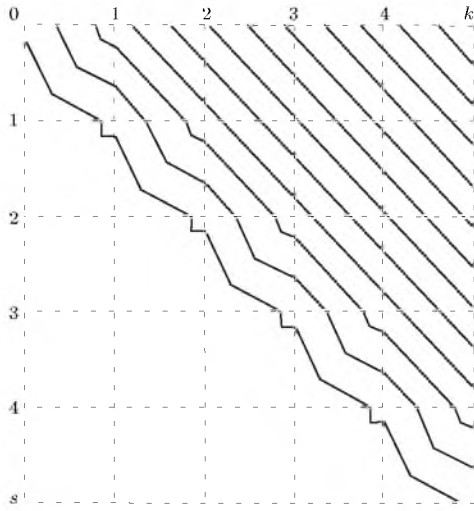
$$\begin{aligned}
 [3.25] \quad \int_0^\infty \tau L_s(\tau, \gamma) L_k^{(2)}(\tau, \gamma) d\tau &= \\
 &= \begin{cases} \frac{1}{\gamma^2}, & \text{если } k \geq s; \\ -\frac{k+1}{\gamma^2}, & \text{если } k = s-1; \\ 0, & \text{иначе.} \end{cases}
 \end{aligned}$$

Матрица значений при  $k = 0.5; s = 0.5$ :

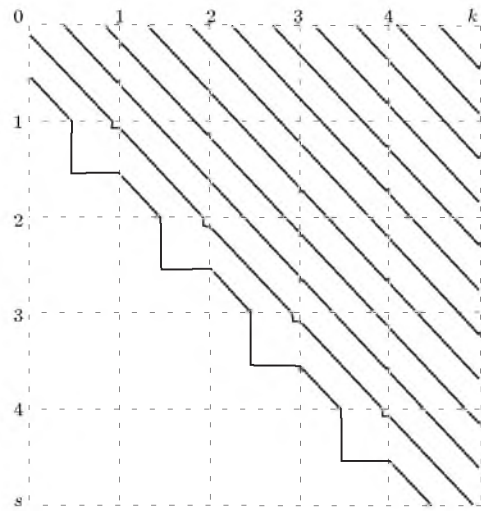
$$\mathcal{M}_{[3.24]} = \frac{1}{\gamma} \begin{pmatrix} 1 & 2 & 3 & 4 & 5 & 6 \\ 0 & 1 & 2 & 3 & 4 & 5 \\ 0 & 0 & 1 & 2 & 3 & 4 \\ 0 & 0 & 0 & 1 & 2 & 3 \\ 0 & 0 & 0 & 0 & 1 & 2 \\ 0 & 0 & 0 & 0 & 0 & 1 \end{pmatrix}$$

Матрица значений при  $k = 0.5; s = 0.5$ :

$$\mathcal{M}_{[3.25]} = \frac{1}{\gamma^2} \begin{pmatrix} 1 & 1 & 1 & 1 & 1 & 1 \\ -1 & 1 & 1 & 1 & 1 & 1 \\ 0 & -2 & 1 & 1 & 1 & 1 \\ 0 & 0 & -3 & 1 & 1 & 1 \\ 0 & 0 & 0 & -4 & 1 & 1 \\ 0 & 0 & 0 & 0 & -5 & 1 \end{pmatrix}$$





Рис. 3.25. Графическое представление соотношения [3.25] при  $k = 0..5, s = 0..5; \gamma = 1$

$$M_{[3.26]} = \begin{pmatrix} -1/2 & -2 & -9/2 & -8 & -25/2 & -18 \\ 0 & -1/2 & -2 & -9/2 & -8 & -25/2 \\ 0 & 0 & -1/2 & -2 & -9/2 & -8 \\ 0 & 0 & 0 & -1/2 & -2 & -9/2 \\ 0 & 0 & 0 & 0 & -1/2 & -2 \\ 0 & 0 & 0 & 0 & 0 & -1/2 \end{pmatrix}$$

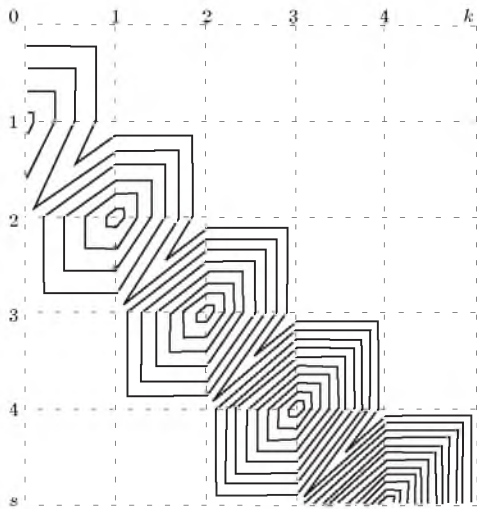

Рис. 3.26. Графическое представление соотношения [3.26] при  $k = 0..5, s = 0..5; \gamma = 1$

$$[3.26] \int_0^\infty L_s(\tau, \gamma) \frac{\partial L_k^{(2)}(\tau, \gamma)}{\partial \tau} d\tau = \begin{cases} -\frac{(k-s+1)^2}{2}, & \text{если } k > s; \\ -\frac{1}{2}, & \text{если } k = s; \\ 0, & \text{иначе.} \end{cases}$$

$$[3.27] \int_0^\infty L_s^{(1)}(\tau, \gamma) \frac{\partial L_k^{(1)}(\tau, \gamma)}{\partial \tau} \mu\{L_s^{(1)}(\tau, \gamma)\}(\tau, \gamma) d\tau = \begin{cases} -\frac{s+1}{\gamma}, & \text{если } k > s; \\ -\frac{k+1}{\gamma}, & \text{если } k = s; \\ 0, & \text{иначе.} \end{cases}$$

Матрица значений при  $k = 0..5; s = 0..5$ :

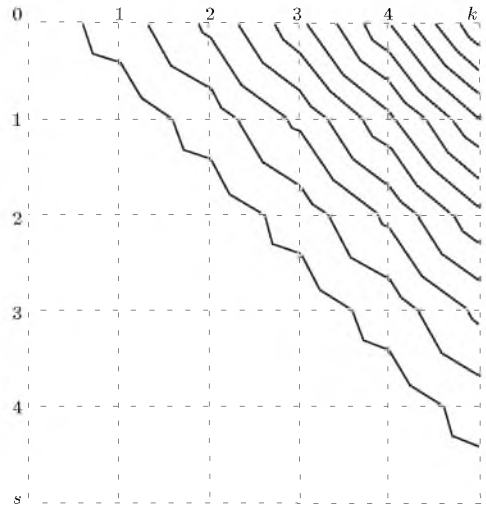
Матрица значений при  $k = 0..5; s = 0..5$ :

$$M_{[3.27]} = \frac{1}{\gamma} \begin{pmatrix} -1/2 & -1 & -1 & -1 & -1 & -1 \\ 0 & -1 & -2 & -2 & -2 & -2 \\ 0 & 0 & -3/2 & -3 & -3 & -3 \\ 0 & 0 & 0 & -2 & -4 & -4 \\ 0 & 0 & 0 & 0 & -5/2 & -5 \\ 0 & 0 & 0 & 0 & 0 & -3 \end{pmatrix}$$



Рис. 3.27. Графическое представление соотношения [3.27] при \$k = 0.5, s = 0.5; \gamma = 1\$

$$\mathcal{M}_{[3.28]} = \frac{1}{\gamma^2} \begin{pmatrix} -1 & -1 & 0 & 0 & 0 & 0 \\ 1 & -2 & -3 & 0 & 0 & 0 \\ 0 & 3 & -3 & -6 & 0 & 0 \\ 0 & 0 & 6 & -4 & -10 & 0 \\ 0 & 0 & 0 & 10 & -5 & -15 \\ 0 & 0 & 0 & 0 & 15 & -6 \end{pmatrix}$$

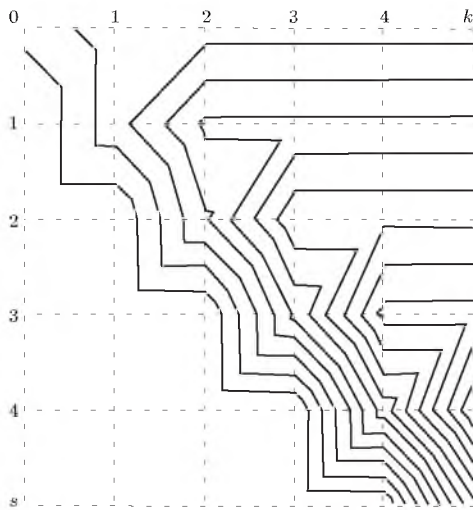

Рис. 3.28. Графическое представление соотношения [3.28] при \$k = 0.5, s = 0.5; \gamma = 1\$

$$[3.28] \int_0^\infty \tau L_s^{(1)}(\tau, \gamma) \frac{\partial L_k^{(1)}(\tau, \gamma)}{\partial \tau} \mu_{\{L_s^{(1)}(\tau, \gamma)\}}(\tau, \gamma) d\tau = \begin{cases} -\frac{(s+1)(s+2)}{2\gamma^2}, & \text{если } k = s+1; \\ -\frac{k+1}{\gamma^2}, & \text{если } k = s; \\ -\frac{s(s+1)}{2\gamma^2}, & \text{если } k = s-1; \\ 0, & \text{иначе.} \end{cases}$$

$$[3.29] \int_0^\infty L_s^{(2)}(\tau, \gamma) \frac{\partial L_k^{(2)}(\tau, \gamma)}{\partial \tau} \mu_{\{L_s^{(2)}(\tau, \gamma)\}}(\tau, \gamma) d\tau = \begin{cases} -\frac{(s+1)(s+2)}{\gamma^2}, & \text{если } k > s; \\ -\frac{(k+1)(k+2)}{2\gamma^2}, & \text{если } k = s; \\ 0, & \text{иначе.} \end{cases}$$

Матрица значений при \$k = 0.5; s = 0.5\$:

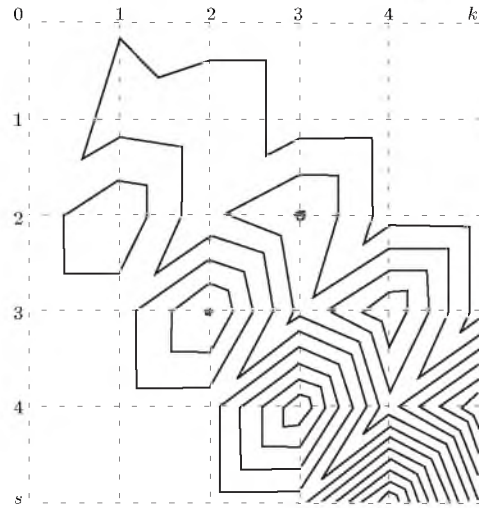
Матрица значений при \$k = 0.5; s = 0.5\$:

$$\mathcal{M}_{[3.29]} = \frac{1}{\gamma^2} \begin{pmatrix} -1 & -2 & -2 & -2 & -2 & -2 \\ 0 & -3 & -6 & -6 & -6 & -6 \\ 0 & 0 & -6 & -12 & -12 & -12 \\ 0 & 0 & 0 & -10 & -20 & -20 \\ 0 & 0 & 0 & 0 & -15 & -30 \\ 0 & 0 & 0 & 0 & 0 & -21 \end{pmatrix}$$



Рис. 3.29. Графическое представление соотношения [3.29] при  $k = 0.5, s = 0.5; \gamma = 1$

$$\mathcal{M}_{[3.30]} = \frac{1}{\gamma^3} \begin{pmatrix} -3 & -3 & 0 & 0 & 0 & 0 \\ 3 & -9 & -12 & 0 & 0 & 0 \\ 0 & 12 & -18 & -30 & 0 & 0 \\ 0 & 0 & 30 & -30 & -60 & 0 \\ 0 & 0 & 0 & 60 & -45 & -105 \\ 0 & 0 & 0 & 0 & 105 & -63 \end{pmatrix}$$

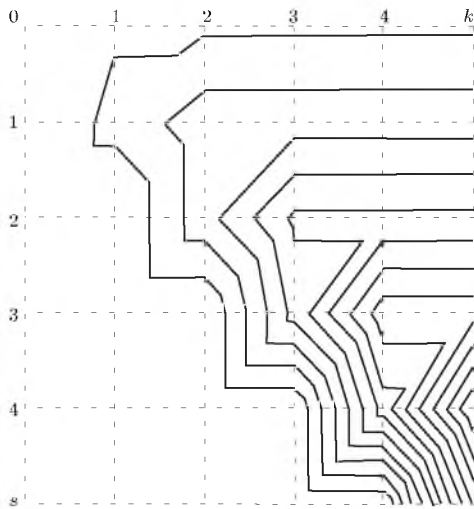

Рис. 3.30. Графическое представление соотношения [3.30] при  $k = 0.5, s = 0.5; \gamma = 1$

$$[3.30] \int_0^\infty \tau L_s^{(2)}(\tau, \gamma) \frac{\partial L_k^{(2)}(\tau, \gamma)}{\partial \tau} \mu^{\{L_s^{(2)}(\tau, \gamma)\}}(\tau, \gamma) d\tau = \begin{cases} -\frac{(s+1)(s+2)(s+3)}{2\gamma^3}, & \text{если } k = s+1; \\ -\frac{3(k+1)(k+2)}{2\gamma^3}, & \text{если } k = s; \\ -\frac{s(s+1)(s+2)}{2\gamma^3}, & \text{если } k = s-1; \\ 0, & \text{иначе.} \end{cases}$$

Матрица значений при  $k = 0.5; s = 0.5$ :

$$[3.31] \int_0^\infty P_s^{(0,1)}(\tau, \gamma) Leg_k(\tau, \gamma) \mu^{\{P_s^{(0,1)}(\tau, \gamma)\}}(\tau, \gamma) d\tau = \begin{cases} \frac{1}{4(2k+1)\gamma}, & \text{если } k = s+1; \\ \frac{1}{4(2k+1)\gamma}, & \text{если } k = s; \\ 0, & \text{иначе.} \end{cases}$$

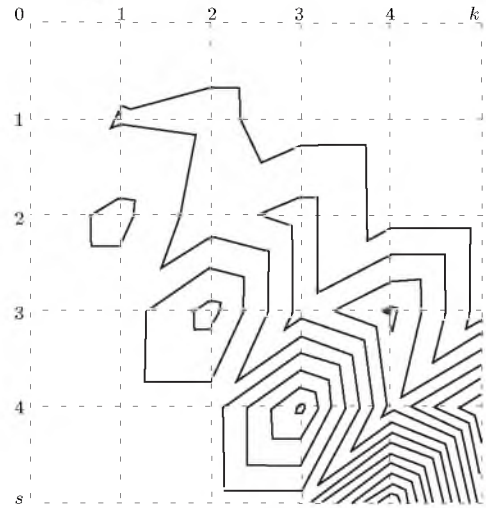
Матрица значений при  $k = 0.5; s = 0.5$ :

$$\mathcal{M}_{[3.31]} = \frac{1}{\gamma} \begin{pmatrix} 1/4 & 1/12 & 0 & 0 & 0 & 0 \\ 0 & 1/12 & 1/20 & 0 & 0 & 0 \\ 0 & 0 & 1/20 & 1/28 & 0 & 0 \\ 0 & 0 & 0 & 1/28 & 1/36 & 0 \\ 0 & 0 & 0 & 0 & 1/36 & 1/44 \\ 0 & 0 & 0 & 0 & 0 & 1/44 \end{pmatrix}$$



Рис. 3.31. Графическое представление соотношения [3.31] при  $k = 0.5, s = 0.5; \gamma = 1$

$$\mathcal{M}_{[3.32]} = \frac{1}{\gamma} \begin{pmatrix} 1/6 & 1/12 & 1/60 & 0 & 0 & 0 \\ 0 & 1/20 & 1/20 & 1/70 & 0 & 0 \\ 0 & 0 & 1/35 & 1/28 & 1/84 & 0 \\ 0 & 0 & 0 & 5/252 & 1/36 & 1/99 \\ 0 & 0 & 0 & 0 & 7/572 & 1/44 \\ 0 & 0 & 0 & 0 & 0 & 2/195 \end{pmatrix}$$

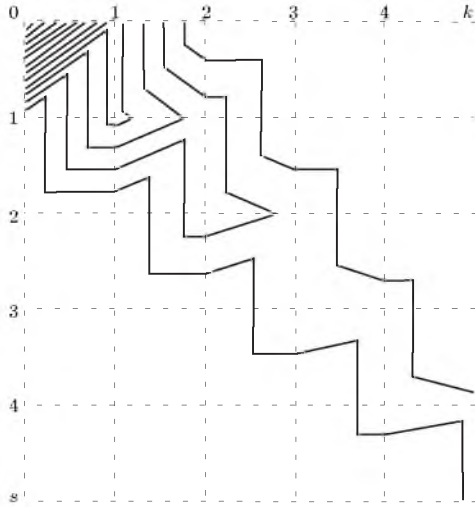

Рис. 3.32. Графическое представление соотношения [3.32] при  $k = 0.5, s = 0.5; \gamma = 1$

$$[3.32] \int_0^\infty P_s^{(0,2)}(\tau, \gamma) Leg_k(\tau, \gamma) \mu^{\{P_s^{(0,2)}(\tau, \gamma)\}}(\tau, \gamma) d\tau = \begin{cases} \frac{k-1}{4(2k-1)(2k+1)\gamma}, & \text{если } k = s+2; \\ \frac{1}{4(2k+1)\gamma}, & \text{если } k = s+1; \\ \frac{k+2}{4(2k+1)(2k+3)\gamma}, & \text{если } k = s; \\ 0, & \text{иначе.} \end{cases}$$

$$[3.33] \int_0^\infty P_s^{(0,2)}(\tau, \gamma) P_k^{(0,1)}(\tau, \gamma) \mu^{\{P_s^{(0,2)}(\tau, \gamma)\}}(\tau, \gamma) d\tau = \begin{cases} \frac{k}{4(k+1)(2k+1)\gamma}, & \text{если } k = s+1; \\ \frac{k+2}{4(k+1)(2k+3)\gamma}, & \text{если } k = s; \\ 0, & \text{иначе.} \end{cases}$$

Матрица значений при  $k = 0.5; s = 0.5$ :

Матрица значений при  $k = 0.5; s = 0.5$

$$\mathcal{M}_{[3.33]} = \frac{1}{\gamma} \begin{pmatrix} 1/6 & 1/24 & 0 & 0 & 0 & 0 \\ 0 & 3/40 & 1/30 & 0 & 0 & 0 \\ 0 & 0 & 1/21 & 3/112 & 0 & 0 \\ 0 & 0 & 0 & 5/144 & 1/45 & 0 \\ 0 & 0 & 0 & 0 & 3/110 & 5/264 \\ 0 & 0 & 0 & 0 & 0 & 7/312 \end{pmatrix}$$



Рис. 3.33. Графическое представление соотношения [3.33] при  $k = 0.5, s = 0.5; \gamma = 1$

$$[3.34] \int_0^\infty P_s^{(-1/2,0)}(\tau, \gamma) \frac{\partial P_k^{(-1/2,0)}(\tau, \gamma)}{\partial \tau} d\tau = \begin{cases} -(-1)^{k+s}, & \text{если } k > s; \\ -\frac{1}{2}, & \text{если } k = s; \\ 0, & \text{иначе.} \end{cases}$$

Матрица значений при  $k = 0..5; s = 0..5$

$$\mathcal{M}_{[3.34]} = \begin{pmatrix} -1/2 & 1 & -1 & 1 & -1 & 1 \\ 0 & -1/2 & 1 & -1 & 1 & -1 \\ 0 & 0 & -1/2 & 1 & -1 & 1 \\ 0 & 0 & 0 & -1/2 & 1 & -1 \\ 0 & 0 & 0 & 0 & -1/2 & 1 \\ 0 & 0 & 0 & 0 & 0 & -1/2 \end{pmatrix}$$

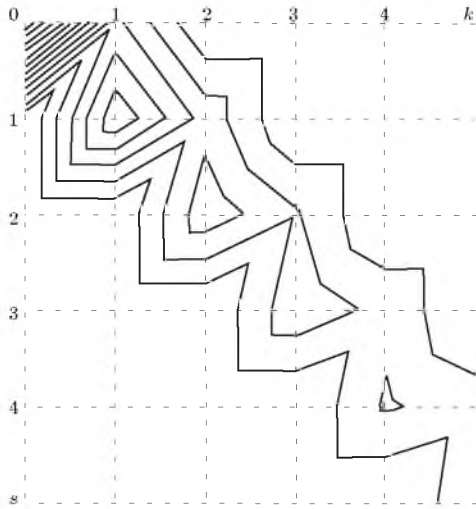

Рис. 3.34. Графическое представление соотношения [3.34] при  $k = 0.5, s = 0.5; \gamma = 1$

$$[3.35] \int_0^\infty Leg_s(\tau, \gamma) \frac{\partial Leg_k(\tau, \gamma)}{\partial \tau} d\tau = \begin{cases} -(-1)^{k+s}, & \text{если } k > s; \\ -\frac{1}{2}, & \text{если } k = s; \\ 0, & \text{иначе.} \end{cases}$$

Матрица значений при  $k = 0..5; s = 0..5$

$$\mathcal{M}_{[3.35]} = \begin{pmatrix} -1/2 & 1 & -1 & 1 & -1 & 1 \\ 0 & -1/2 & 1 & -1 & 1 & -1 \\ 0 & 0 & -1/2 & 1 & -1 & 1 \\ 0 & 0 & 0 & -1/2 & 1 & -1 \\ 0 & 0 & 0 & 0 & -1/2 & 1 \\ 0 & 0 & 0 & 0 & 0 & -1/2 \end{pmatrix}$$

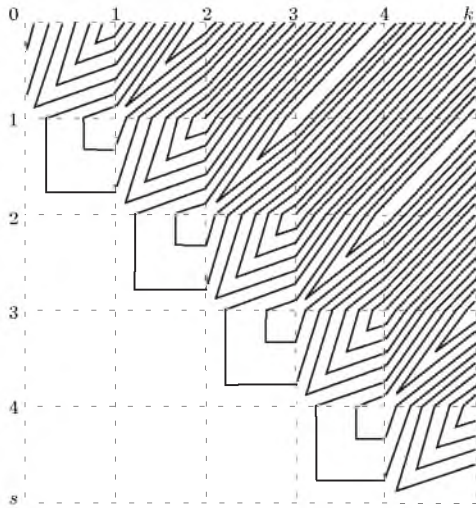

Рис. 3.35. Графическое представление соотношения [3.35] при  $k = 0.5, s = 0.5; \gamma = 1$

$$[3.36] \int_0^\infty P_s^{(1/2,0)}(\tau, \gamma) \frac{\partial P_k^{(1/2,0)}(\tau, \gamma)}{\partial \tau} d\tau = \begin{cases} -(-1)^{k+s}, & \text{если } k > s; \\ -\frac{1}{2}, & \text{если } k = s; \\ 0, & \text{иначе.} \end{cases}$$

Матрица значений при  $k = 0..5; s = 0..5$

$$\mathcal{M}_{[3.36]} = \begin{pmatrix} -1/2 & 1 & -1 & 1 & -1 & 1 \\ 0 & -1/2 & 1 & -1 & 1 & -1 \\ 0 & 0 & -1/2 & 1 & -1 & 1 \\ 0 & 0 & 0 & -1/2 & 1 & -1 \\ 0 & 0 & 0 & 0 & -1/2 & 1 \\ 0 & 0 & 0 & 0 & 0 & -1/2 \end{pmatrix}$$

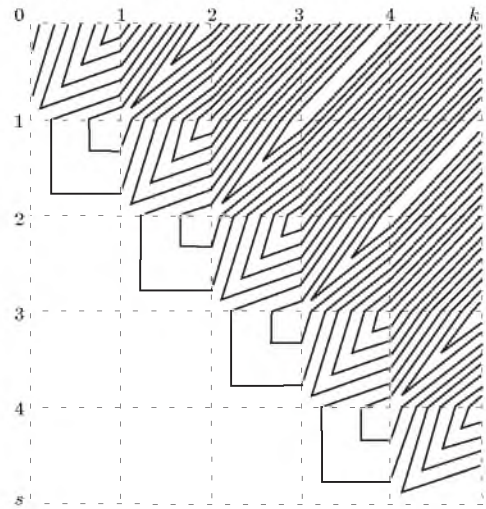

Рис. 3.36. Графическое представление соотношения [3.36] при  $k = 0.5, s = 0.5; \gamma = 1$

$$[3.37] \int_0^{\infty} P_s^{(1,0)}(\tau, \gamma) \frac{\partial P_k^{(1,0)}(\tau, \gamma)}{\partial \tau} d\tau = \begin{cases} -(-1)^{k+s}, & \text{если } k > s; \\ -\frac{1}{2}, & \text{если } k = s; \\ 0, & \text{иначе.} \end{cases}$$

Матрица значений при  $k = 0.5; s = 0.5$

$$\mathcal{M}_{[3.37]} = \begin{pmatrix} -1/2 & 1 & -1 & 1 & -1 & 1 \\ 0 & -1/2 & 1 & -1 & 1 & -1 \\ 0 & 0 & -1/2 & 1 & -1 & 1 \\ 0 & 0 & 0 & -1/2 & 1 & -1 \\ 0 & 0 & 0 & 0 & -1/2 & 1 \\ 0 & 0 & 0 & 0 & 0 & -1/2 \end{pmatrix}$$

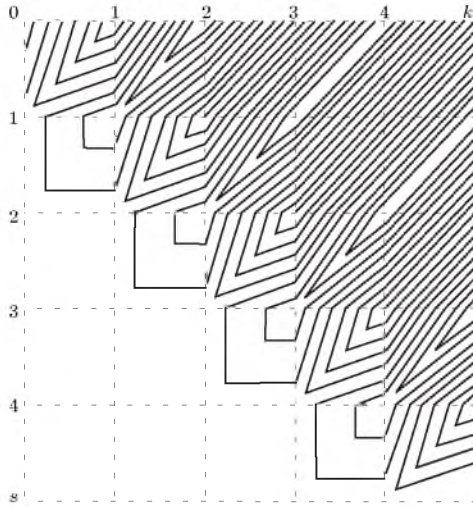

Рис. 3.37. Графическое представление соотношения [3.37] при  $k = 0.5, s = 0.5; \gamma = 1$

$$[3.38] \int_0^{\infty} P_s^{(2,0)}(\tau, \gamma) \frac{\partial P_k^{(2,0)}(\tau, \gamma)}{\partial \tau} d\tau = \begin{cases} -(-1)^{k+s}, & \text{если } k > s; \\ -\frac{1}{2}, & \text{если } k = s; \\ 0, & \text{иначе.} \end{cases}$$

Матрица значений при  $k = 0.5; s = 0.5$

$$\mathcal{M}_{[3.38]} = \begin{pmatrix} -1/2 & 1 & -1 & 1 & -1 & 1 \\ 0 & -1/2 & 1 & -1 & 1 & -1 \\ 0 & 0 & -1/2 & 1 & -1 & 1 \\ 0 & 0 & 0 & -1/2 & 1 & -1 \\ 0 & 0 & 0 & 0 & -1/2 & 1 \\ 0 & 0 & 0 & 0 & 0 & -1/2 \end{pmatrix}$$

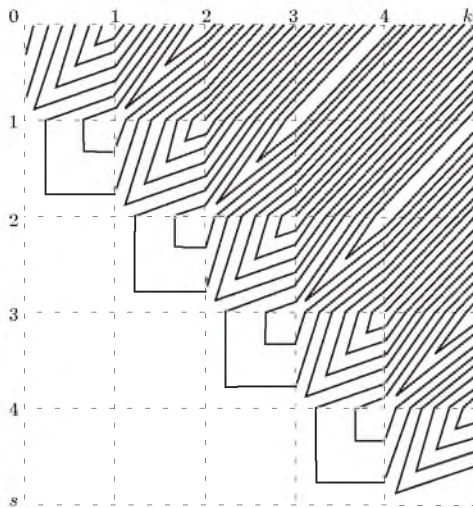

Рис. 3.38. Графическое представление соотношения [3.38] при  $k = 0.5, s = 0.5; \gamma = 1$

$$[3.39] \int_0^{\infty} P_s^{(\alpha,0)}(\tau, \gamma) \frac{\partial P_k^{(\alpha,0)}(\tau, \gamma)}{\partial \tau} d\tau = \begin{cases} -(-1)^{k+s}, & \text{если } k > s; \\ -\frac{1}{2}, & \text{если } k = s; \\ 0, & \text{иначе.} \end{cases}$$

$$[3.40] \int_0^{\infty} P_s^{(-1/2,0)}(\tau, \gamma) \left( \int P_k^{(-1/2,0)}(\tau, \gamma) d\tau \right) d\tau = \begin{cases} \frac{2}{(4k+1)^2 \gamma^2}, & \text{если } k = s; \\ \frac{(4s+1)(4k+1) \gamma^2}{4}, & \text{если } k < s; \\ 0, & \text{иначе.} \end{cases}$$

Матрица значений при  $k = 0.5; s = 0.5$ :

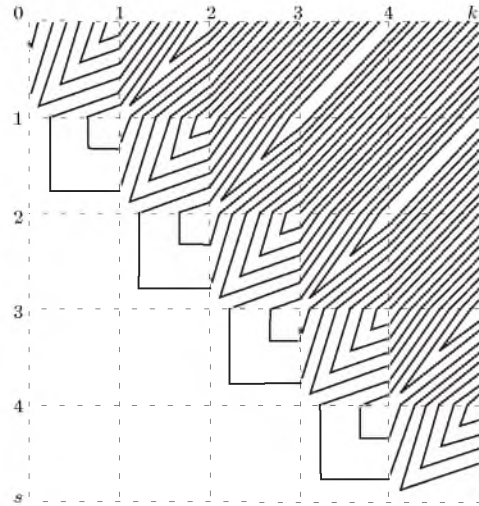
$$\mathcal{M}_{[3.40]} = \frac{1}{\gamma^2} \times$$



Рис. 3.39. Графическое представление соотношения [3.40] при  $k = 0..5, s = 0..5; \gamma = 1$



Рис. 3.40. Графическое представление соотношения [3.41] при  $k = 0..5, s = 0..5; \gamma = 1$

$$[3.41] \int_0^\infty Leg_s(\tau, \gamma) \left( \int Leg_k(\tau, \gamma) d\tau \right) d\tau = \begin{cases} \frac{1}{2(2k+1)^2\gamma^2}, & \text{если } k = s; \\ \frac{1}{(2s+1)(2k+1)\gamma^2}, & \text{если } k < s; \\ 0, & \text{иначе.} \end{cases}$$

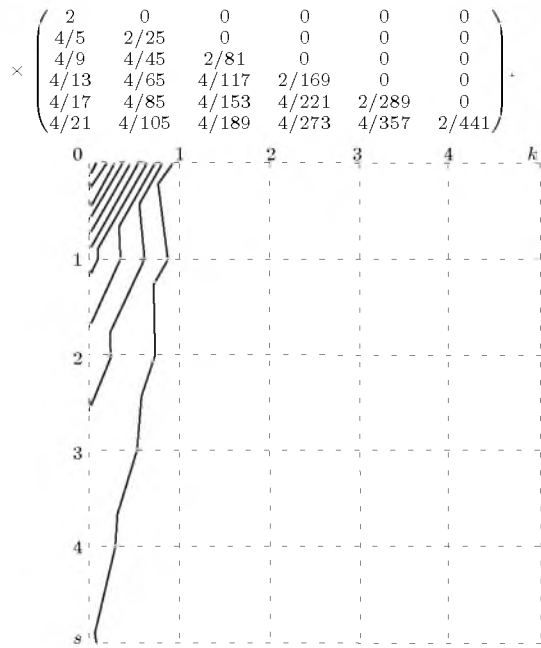
$$[3.42] \int_0^\infty P_s^{(1/2,0)}(\tau, \gamma) \left( \int P_k^{(1/2,0)}(\tau, \gamma) d\tau \right) d\tau = \begin{cases} \frac{2}{(4k+3)^2\gamma^2}, & \text{если } k = s; \\ \frac{1}{(4s+3)(4k+3)\gamma^2}, & \text{если } k < s; \\ 0, & \text{иначе.} \end{cases}$$

Матрица значений при  $k = 0..5; s = 0..5$ :

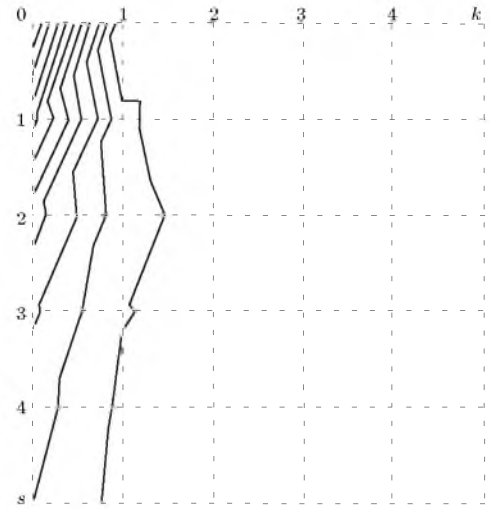
$$\mathcal{M}_{[3.41]} = \frac{1}{\gamma^2} \begin{pmatrix} 1/2 & 0 & 0 & 0 & 0 & 0 \\ 1/3 & 1/18 & 0 & 0 & 0 & 0 \\ 1/5 & 1/15 & 1/50 & 0 & 0 & 0 \\ 1/7 & 1/21 & 1/35 & 1/98 & 0 & 0 \\ 1/9 & 1/27 & 1/45 & 1/63 & 1/162 & 0 \\ 1/11 & 1/33 & 1/55 & 1/77 & 1/99 & 1/242 \end{pmatrix}$$

Матрица значений при  $k = 0..5; s = 0..5$ :

$$\mathcal{M}_{[3.42]} = \frac{1}{\gamma^2} \times \begin{pmatrix} 2/9 & 0 & 0 & 0 & 0 & 0 \\ 4/21 & 2/49 & 0 & 0 & 0 & 0 \\ 4/33 & 4/77 & 2/121 & 0 & 0 & 0 \\ 4/45 & 4/105 & 4/165 & 2/225 & 0 & 0 \\ 4/57 & 4/133 & 4/209 & 4/285 & 2/361 & 0 \\ 4/69 & 4/161 & 4/253 & 4/345 & 4/437 & 2/529 \end{pmatrix}$$



Рис. 3.41. Графическое представление соотношения [3.42] при  $k = 0.5, s = 0.5; \gamma = 1$

$$\mathcal{M}_{[3.43]} = \frac{1}{\gamma^2} \begin{pmatrix} 1/2 & 0 & 0 & 0 & 0 & 0 \\ 1/2 & 1/8 & 0 & 0 & 0 & 0 \\ 1/3 & 1/6 & 1/18 & 0 & 0 & 0 \\ 1/4 & 1/8 & 1/12 & 1/32 & 0 & 0 \\ 1/5 & 1/10 & 1/15 & 1/20 & 1/50 & 0 \\ 1/6 & 1/12 & 1/18 & 1/24 & 1/30 & 1/72 \end{pmatrix}$$

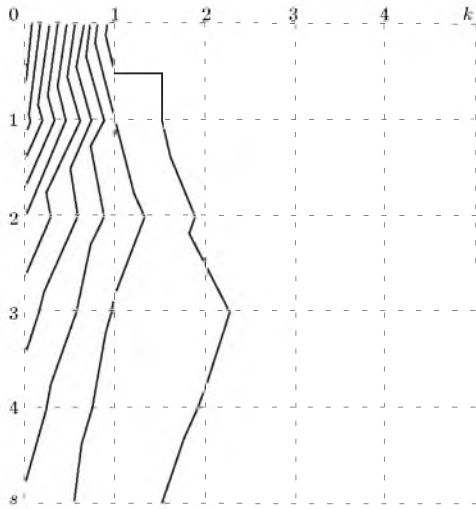

Рис. 3.42. Графическое представление соотношения [3.43] при  $k = 0.5, s = 0.5; \gamma = 1$

$$[3.43] \int_0^\infty P_s^{(1,0)}(\tau, \gamma) \left( \int P_k^{(1,0)}(\tau, \gamma) d\tau \right) d\tau = \begin{cases} \frac{1}{2(k+1)^2 \gamma^2}, & \text{если } k = s; \\ \frac{1}{(s+1)(k+1) \gamma^2}, & \text{если } k < s; \\ 0, & \text{иначе.} \end{cases}$$

$$[3.44] \int_0^\infty P_s^{(2,0)}(\tau, \gamma) \left( \int P_k^{(2,0)}(\tau, \gamma) d\tau \right) d\tau = \begin{cases} \frac{1}{2(2k+3)^2 \gamma^2}, & \text{если } k = s; \\ \frac{1}{(2s+3)(2k+3) \gamma^2}, & \text{если } k < s; \\ 0, & \text{иначе.} \end{cases}$$

Матрица значений при  $k = 0.5; s = 0.5$ :

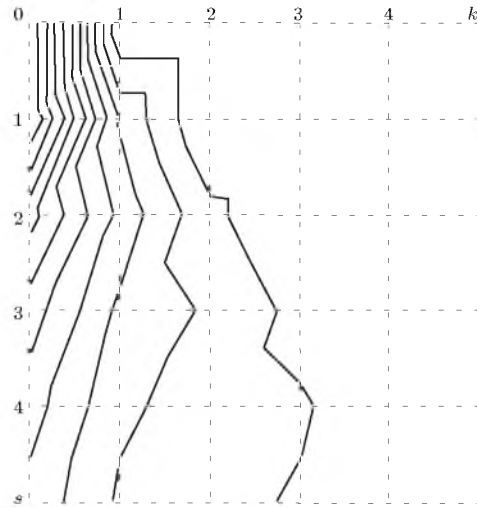
Матрица значений при  $k = 0.5; s = 0.5$ :

$$\mathcal{M}_{[3.44]} = \frac{1}{\gamma^2} \begin{pmatrix} 1/18 & 0 & 0 & 0 & 0 & 0 \\ 1/15 & 1/50 & 0 & 0 & 0 & 0 \\ 1/21 & 1/35 & 1/98 & 0 & 0 & 0 \\ 1/27 & 1/45 & 1/63 & 1/162 & 0 & 0 \\ 1/33 & 1/55 & 1/77 & 1/99 & 1/242 & 0 \\ 1/39 & 1/65 & 1/91 & 1/117 & 1/143 & 1/338 \end{pmatrix}$$





Рис. 3.43. Графическое представление соотношения [3.44] при  $k = 0.5, s = 0.5; \gamma = 1$



Рис. 3.44. Графическое представление соотношения [3.46] при  $k = 0.5, s = 0.5; \gamma = 1$

$$[3.45] \int_0^\infty P_s^{(\alpha,0)}(\tau, \gamma) \left( \int P_k^{(\alpha,0)}(\tau, \gamma) d\tau \right) d\tau = \begin{cases} \frac{2}{(2k + \alpha + 1)^2 c^2 \gamma^2}, & \text{если } k = s; \\ \frac{1}{(2s + 3)(2k + 3)c^2 \gamma^2}, & \text{если } k < s; \\ 0, & \text{иначе.} \end{cases}$$

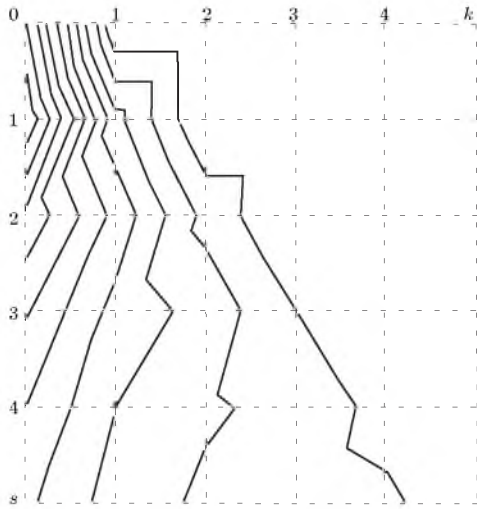
$$[3.46] \int_0^\infty Leg_s(\tau, \gamma) P_k^{(0,1)}(\tau, \gamma) d\tau = \begin{cases} \frac{(-1)^{k+s}}{2\gamma(k+1)}, & \text{если } k > s; \\ \frac{1}{2\gamma(k+1)}, & \text{если } k = s; \\ 0, & \text{иначе.} \end{cases}$$

Матрица значений при  $k = 0.5; s = 0.5$ :

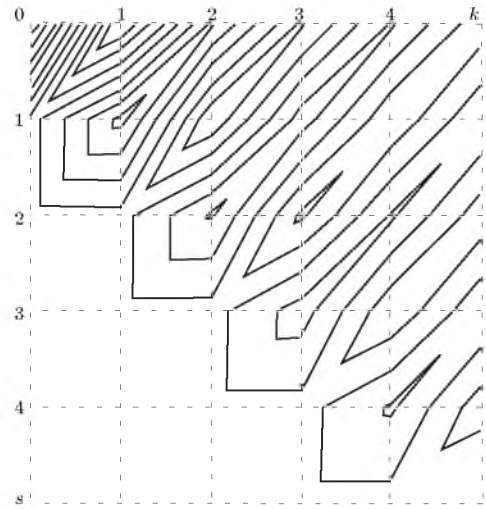
$$\mathcal{M}_{[3.46]} = \frac{1}{\gamma} \begin{pmatrix} 1/2 & -1/4 & 1/6 & -1/8 & 1/10 & -1/12 \\ 0 & 1/4 & -1/6 & 1/8 & -1/10 & 1/12 \\ 0 & 0 & 1/6 & 1/8 & -1/10 & 1/12 \\ 0 & 0 & 0 & 1/8 & -1/10 & 1/12 \\ 0 & 0 & 0 & 0 & 1/10 & 1/12 \\ 0 & 0 & 0 & 0 & 0 & 1/12 \end{pmatrix}^+$$

$$[3.47] \int_0^\infty Leg_s(\tau, \gamma) \frac{\partial P_k^{(0,1)}(\tau, \gamma)}{\partial \tau} d\tau = \begin{cases} -(-1)^{k+s} \left( \frac{2k+1}{2(k+1)} - \frac{2s(s+1) - 2k(k+1)}{2(k+1)} \right), & \text{если } k > s; \\ -\frac{2k+1}{2(k+1)}, & \text{если } k = s; \\ 0, & \text{иначе.} \end{cases}$$

Матрица значений при  $k = 0.5; s = 0.5$ :

$$\mathcal{M}_{[3.47]} = \begin{pmatrix} -1/2 & 7/4 & -17/6 & 31/8 & -49/10 & 71/12 \\ 0 & -3/4 & 13/6 & -27/8 & 9/2 & -67/12 \\ 0 & 0 & -5/6 & 19/8 & -37/10 & 59/12 \\ 0 & 0 & 0 & -7/8 & 5/2 & -47/12 \\ 0 & 0 & 0 & 0 & -9/10 & 31/12 \\ 0 & 0 & 0 & 0 & 0 & -11/12 \end{pmatrix}^+$$



Рис. 3.45. Графическое представление соотношения [3.47] при  $k = 0.5, s = 0.5; \gamma = 1$

$$[3.48] \int_0^\infty Leg_s(\tau, \gamma) P_k^{(0,2)}(\tau, \gamma) d\tau = \begin{cases} (-1)^{k+s} \left( \frac{(k+1)(k+2)}{2\gamma(k+1)(k+2)} - \frac{s(s+1)}{2\gamma(k+1)(k+2)} \right), & \text{если } k > s; \\ \frac{1}{\gamma(k+2)}, & \text{если } k = s; \\ 0, & \text{иначе.} \end{cases}$$

Матрица значений при  $k = 0.5; s = 0.5$ :

$$\mathcal{M}_{[3.48]} = \frac{1}{\gamma} \times \begin{pmatrix} 1/2 & -1/2 & 1/2 & -1/2 & 1/2 & -1/2 \\ 0 & 1/3 & -5/12 & 9/20 & -7/15 & 10/21 \\ 0 & 0 & 1/4 & -7/20 & 2/5 & -3/7 \\ 0 & 0 & 0 & 1/5 & -3/10 & 5/14 \\ 0 & 0 & 0 & 0 & 1/6 & -11/42 \\ 0 & 0 & 0 & 0 & 0 & 1/7 \end{pmatrix}$$

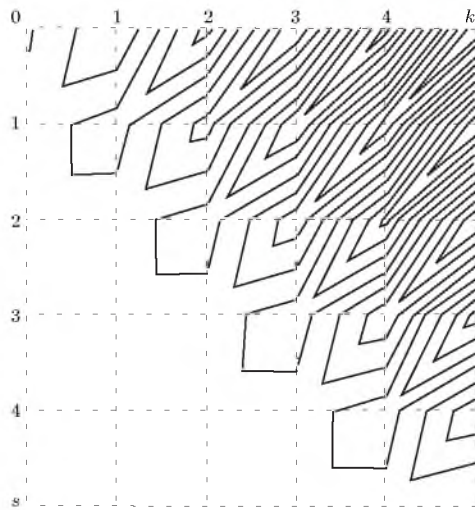

Рис. 3.46. Графическое представление соотношения [3.48] при  $k = 0.5, s = 0.5; \gamma = 1$

$$[3.49] \int_0^\infty Leg_s(\tau, \gamma) \frac{\partial P_k^{(0,2)}(\tau, \gamma)}{\partial \tau} d\tau = \begin{cases} -(-1)^{k+s} \left( \frac{(k(k+3)+1)}{2} - \frac{(2k(k+3)+3)s(s+1)}{2(k+1)(k+2)} \right), & \text{если } k > s; \\ -\frac{(2k+1)}{(k+2)}, & \text{если } k = s; \\ 0, & \text{иначе.} \end{cases}$$

Матрица значений при  $k = 0.5; s = 0.5$ :

$$\mathcal{M}_{[3.49]} = \begin{pmatrix} -1/2 & 5/2 & -11/2 & 19/2 & -29/2 & 41/2 \\ 0 & -1 & 15/4 & -153/20 & 63/5 & -130/7 \\ 0 & 0 & -5/4 & 91/20 & -46/5 & 15 \\ 0 & 0 & 0 & -7/5 & 51/10 & -145/14 \\ 0 & 0 & 0 & 0 & -3/2 & 11/2 \\ 0 & 0 & 0 & 0 & 0 & -11/7 \end{pmatrix}$$

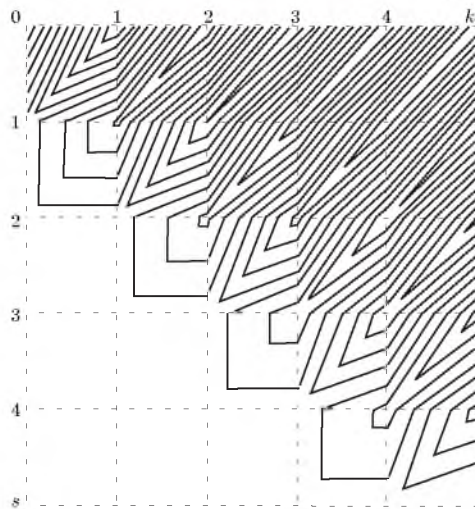

Рис. 3.47. Графическое представление соотношения [3.49] при  $k = 0.5, s = 0.5; \gamma = 1$

## Глава 4

# Фазовые представления ортогональных функций

**Определение.**

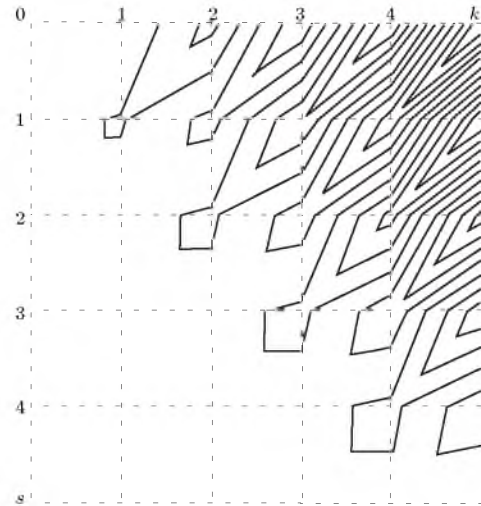
В общем виде определим фазовые ортогональные функции во временной области как [5]

$$\Phi_k^{\{\psi_k(\tau, \gamma)\}}(j\tau) = \psi_k(\tau, \gamma) + j \frac{\partial \psi_k(\tau, \gamma)}{\partial \tau}.$$

Фазовое представление ортогональных функций во временной области обладает следующими основными свойствами:

$$\begin{cases} \operatorname{Re} \Phi_k^{\{\psi_k(\tau, \gamma)\}}(0) = \psi_k(0, \gamma); \\ \int_0^{\infty} \operatorname{Im} \Phi_k^{\{\psi_k(\tau, \gamma)\}}(j\tau) d\tau = -\psi_k(0, \gamma). \end{cases}$$

[4.1]  $\Phi_k^{\{L_k(\tau, \gamma)\}}(j\tau) = L_k(\tau, \gamma) + j \frac{\partial L_k(\tau, \gamma)}{\partial \tau}.$



Рис. 4.1. Вид фазового представления ортогональных функций Лагерра 0-5 порядков;  $\gamma = 2$

[4.2]  $\Phi_k^{\{L_k^{(1)}(\tau, \gamma)\}}(j\tau) = L_k^{(1)}(\tau, \gamma) + j \frac{\partial L_k^{(1)}(\tau, \gamma)}{\partial \tau}.$



Рис. 4.2. Вид фазового представления ортогональных функций Сонина-Лагерра 0-5 порядков;  $\gamma = 2, \alpha = 1$

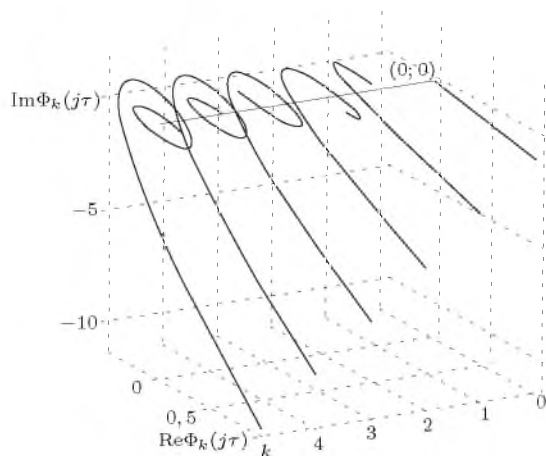

Рис. 4.3. Вид фазового представления ортогональных функций Сонина-Лагерра 0-5 порядков;  $\gamma = 2, \alpha = 2$

[4.3]  $\Phi_k^{\{L_k^{(2)}(\tau, \gamma)\}}(j\tau) = L_k^{(2)}(\tau, \gamma) + j \frac{\partial L_k^{(2)}(\tau, \gamma)}{\partial \tau}$

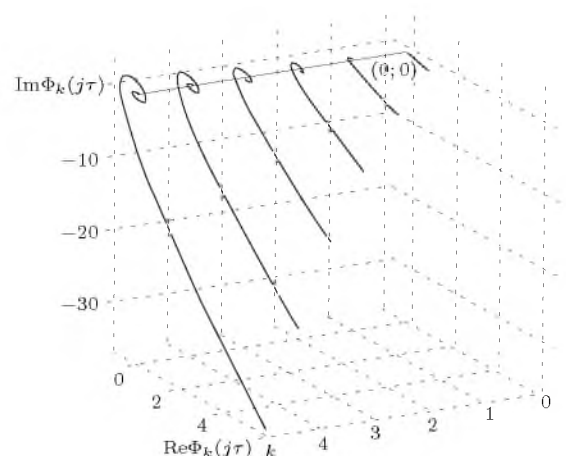
[4.4]  $\Phi_k^{\{L_k^{(\alpha)}(\tau, \gamma)\}}(j\tau) = L_k^{(\alpha)}(\tau, \gamma) + j \frac{\partial L_k^{(\alpha)}(\tau, \gamma)}{\partial \tau}$

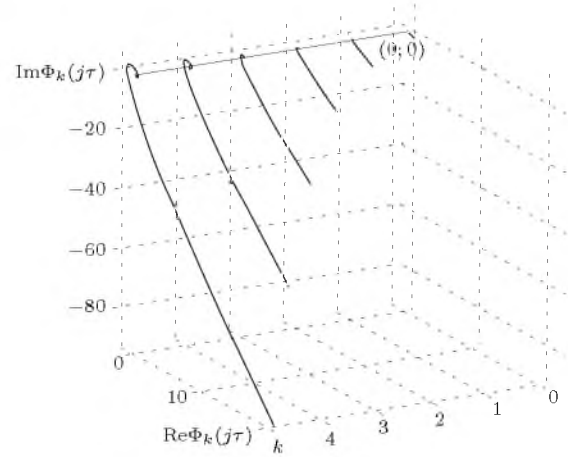

Рис. 4.4. Вид фазового представления ортогональных функций Сонина-Лагерра 2-ого порядка: а)  $\gamma = 2, \alpha \in [0; 5]$ ; б)  $\gamma \in [1; 4], \alpha = 1$

[4.5]  $\Phi_k^{\{P_k^{(-1/2, 0)}(\tau, \gamma)\}}(j\tau) = P_k^{(-1/2, 0)}(\tau, \gamma) + j \frac{\partial P_k^{(-1/2, 0)}(\tau, \gamma)}{\partial \tau}$

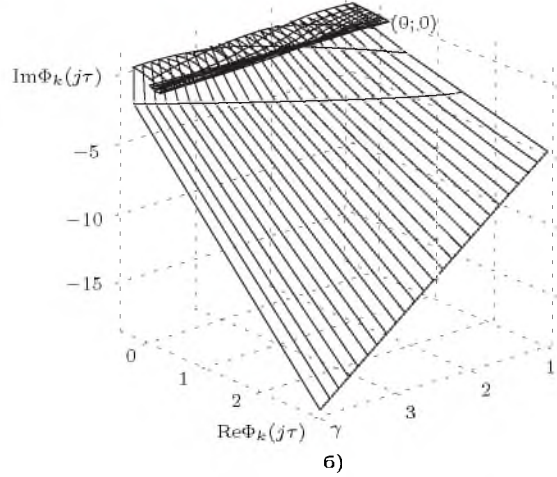
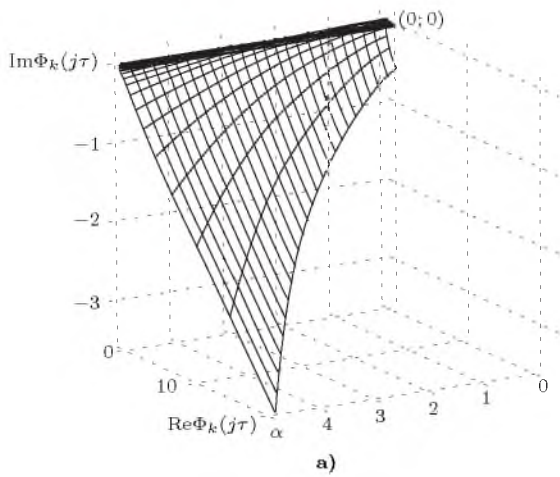

Рис. 4.5. Вид фазового представления ортогональных функций Якоби 0-5 порядков;  $\gamma = 0, 5, c = 2, \alpha = -1/2, \beta = 0$

$$[4.6] \quad \Phi_k^{\{Leg_k(\tau, \gamma)\}}(j\tau) = Leg_k(\tau, \gamma) + j \frac{\partial Leg_k(\tau, \gamma)}{\partial \tau}.$$

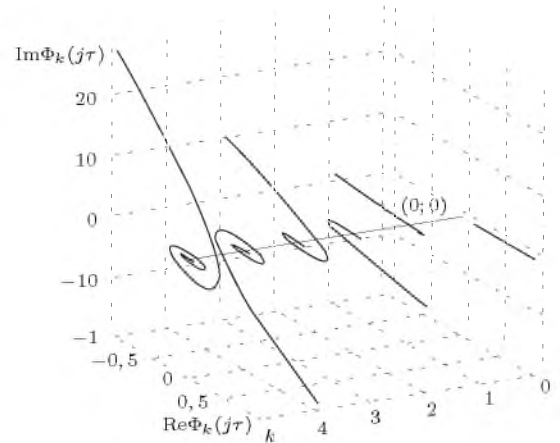

Рис. 4.6. Вид фазового представления ортогональных функций Лежандра 0-5 порядков;  $\gamma = 1, c = 2$

$$[4.7] \quad \Phi_k^{\{P_k^{(1/2,0)}(\tau, \gamma)\}}(j\tau) = P_k^{(1/2,0)}(\tau, \gamma) + j \frac{\partial P_k^{(1/2,0)}(\tau, \gamma)}{\partial \tau}.$$

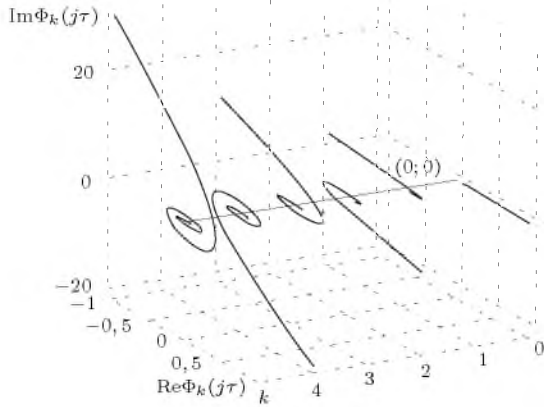

Рис. 4.7. Вид фазового представления ортогональных функций Якоби 0-5 порядков;  $\gamma = 0, 5, c = 2, \alpha = 1/2, \beta = 0$

$$[4.8] \quad \Phi_k^{\{P_k^{(1,0)}(\tau, \gamma)\}}(j\tau) = P_k^{(1,0)}(\tau, \gamma) + j \frac{\partial P_k^{(1,0)}(\tau, \gamma)}{\partial \tau}.$$

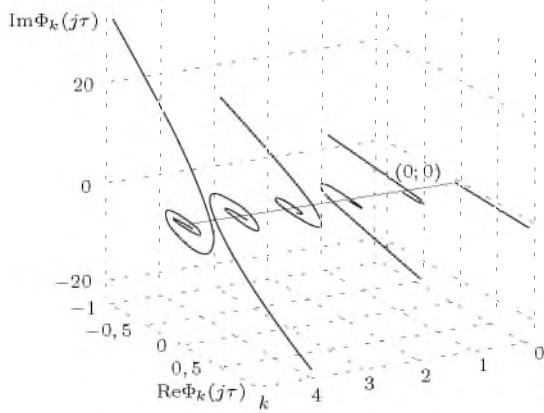

Рис. 4.8. Вид фазового представления ортогональных функций Якоби 0-5 порядков;  $\gamma = 0, 5, c = 1, \alpha = 1, \beta = 0$

$$[4.9] \quad \Phi_k^{\{P_k^{(2,0)}(\tau, \gamma)\}}(j\tau) = P_k^{(2,0)}(\tau, \gamma) + j \frac{\partial P_k^{(2,0)}(\tau, \gamma)}{\partial \tau}.$$

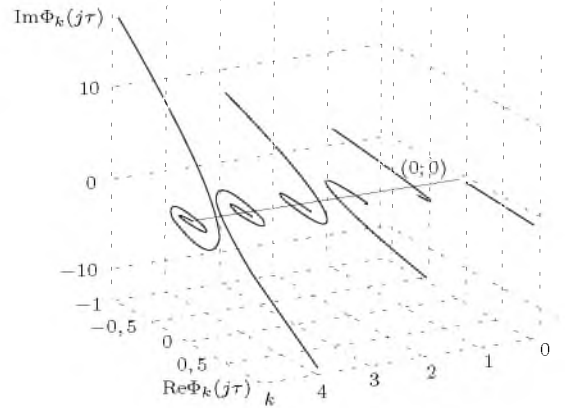

Рис. 4.9. Вид фазового представления ортогональных функций Якоби 0-5 порядков;  $\gamma = 0, 5, c = 2, \alpha = 2, \beta = 0$

$$[4.10] \quad \Phi_k^{\{P_k^{(\alpha,0)}(\tau, \gamma)\}}(j\tau) = P_k^{(\alpha,0)}(\tau, \gamma) + j \frac{\partial P_k^{(\alpha,0)}(\tau, \gamma)}{\partial \tau}.$$

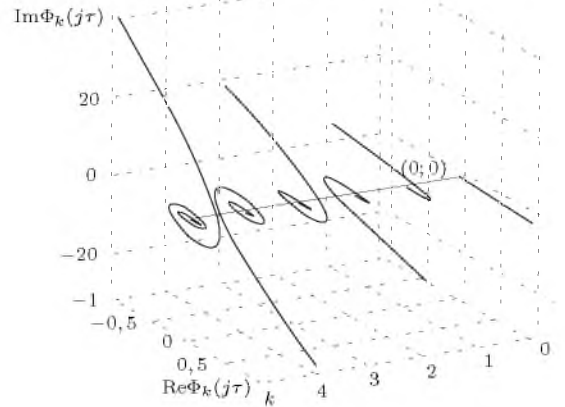

Рис. 4.10. Вид фазового представления ортогональных функций Якоби 2-ого порядка: а)  $\gamma = 0,5, c = 2, \alpha \in [0; 5], \beta = 0$ ; б)  $\gamma \in [0,5; 2,5], c = 2, \alpha = 1, \beta = 0$

$$[4.11] \Phi_k^{\{P_k^{(0,1)}(\tau, \gamma)\}}(j\tau) = P_k^{(0,1)}(\tau, \gamma) + j \frac{\partial P_k^{(0,1)}(\tau, \gamma)}{\partial \tau}$$

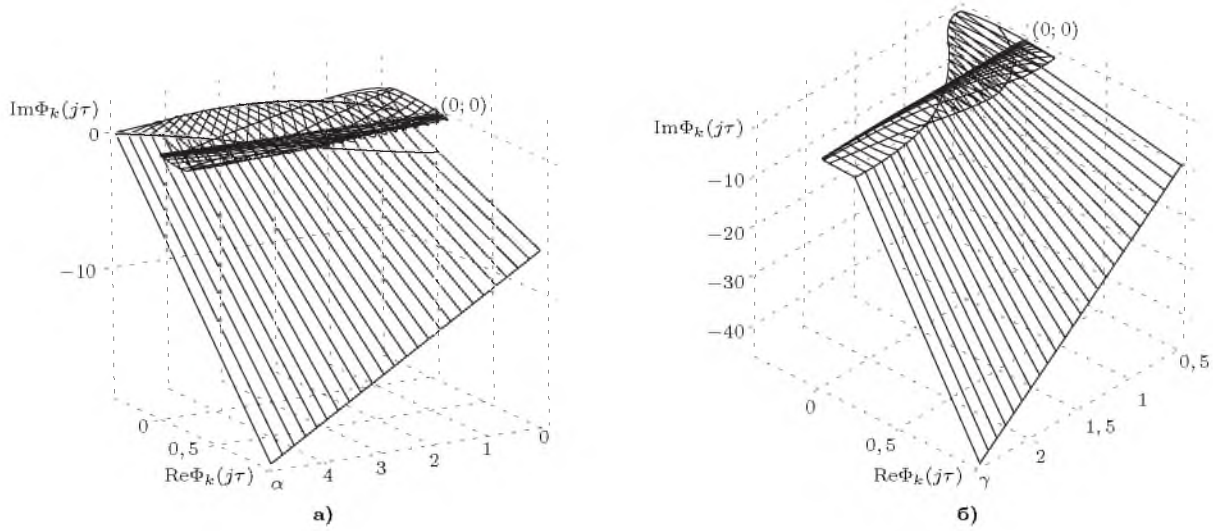

Рис. 4.11. Вид фазового представления ортогональных функций Якоби 0-5 порядков;  $\gamma = 0,5, c = 2, \alpha = 0, \beta = 1$

$$[4.12] \Phi_k^{\{P_k^{(0,2)}(\tau, \gamma)\}}(j\tau) = P_k^{(0,2)}(\tau, \gamma) + j \frac{\partial P_k^{(0,2)}(\tau, \gamma)}{\partial \tau}$$

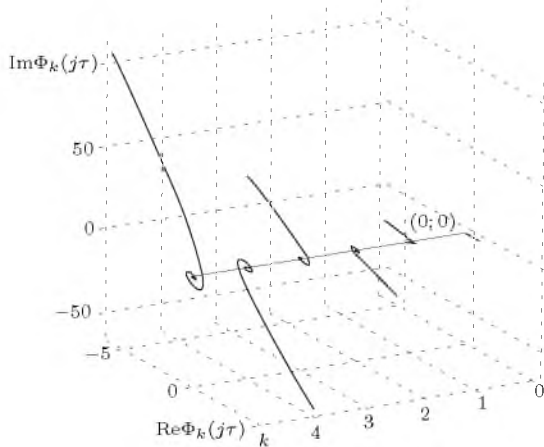

Рис. 4.12. Вид фазового представления ортогональных функций Якоби 0-5 порядков;  $\gamma = 0,5, c = 2, \alpha = 0, \beta = 2$

$$[4.13] \Phi_k^{\{P_k^{(\alpha,0)}(\tau, \gamma)\}}(j\tau) = P_k^{(\alpha,0)}(\tau, \gamma) + j \frac{\partial P_k^{(\alpha,0)}(\tau, \gamma)}{\partial \tau}$$



Рис. 4.13. Вид фазового представления ортогональных функций Якоби 2-ого порядка: а)  $\gamma = 0,5, c = 2, \alpha = 0, \beta \in [0; 5]$ ; б)  $\gamma \in [0, 5; 2], c = 2, \alpha = 0, \beta = 1$

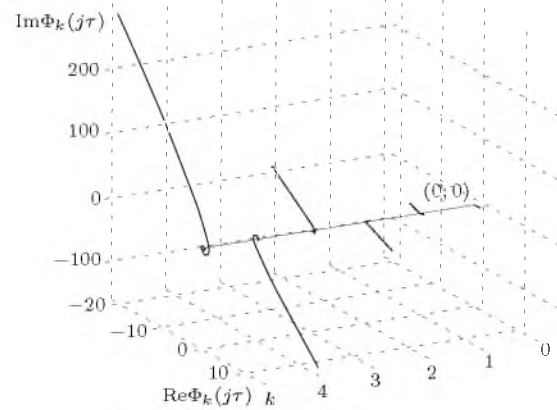

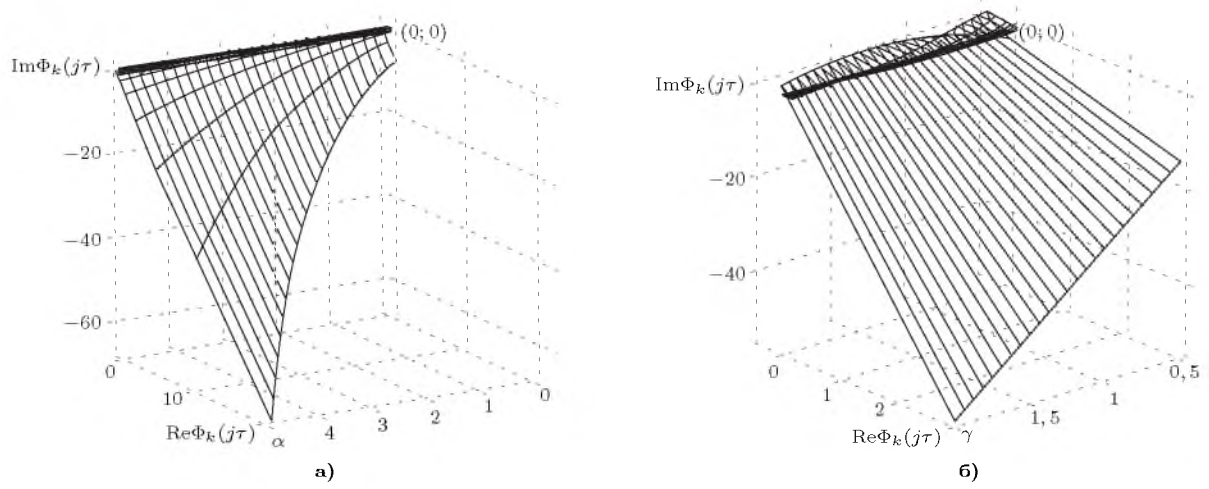

## Глава 5

# Интегральные представления ортогональных функций

### Определение.

Данное определение ортогональных функций введено как обратное преобразование Фурье

$$\psi_k(\tau, \gamma) = \int_0^\infty W_k^{\{\psi_k(\tau, \gamma)\}}(j\omega) \exp(j\omega\tau) d\omega.$$

$$\begin{aligned} \text{[5.1]} \quad L_k(\tau, \gamma) &= \\ &= \frac{2(-1)^k}{\pi} \int_0^{\pi/2} \frac{\cos((2k+1)\phi)}{\cos \phi} \cos\left(\frac{\tau\gamma}{2} \tan \phi\right) d\phi. \end{aligned}$$

$$\begin{aligned} \text{[5.2]} \quad L_k^{(1)}(\tau, \gamma) &= \\ &= \frac{4(-1)^k(k+1)}{\pi\tau\gamma} \int_0^{\pi/2} \cos((2k+2)\phi) \cos\left(\frac{\tau\gamma}{2} \tan \phi\right) d\phi. \end{aligned}$$

$$\begin{aligned} \text{[5.3]} \quad L_k^{(2)}(\tau, \gamma) &= \frac{8(-1)^k(k+1)(k+2)}{\pi(\tau\gamma)^2} \times \\ &\times \int_0^{\pi/2} \cos((2k+3)\phi) \cos \phi \cos\left(\frac{\tau\gamma}{2} \tan \phi\right) d\phi. \end{aligned}$$

$$\begin{aligned} \text{[5.4]} \quad L_k^{(\alpha)}(\tau, \gamma) &= \frac{2^{\alpha+1}(-1)^k(k+\alpha)!}{\pi(\tau\gamma)^\alpha k!} \times \\ &\times \int_0^{\pi/2} \cos((2k+\alpha+1)\phi) (\cos \phi)^{\alpha-1} \cos\left(\frac{\tau\gamma}{2} \tan \phi\right) d\phi. \end{aligned}$$

$$\begin{aligned} \text{[5.5]} \quad P_k^{(-1/2,0)}(\tau, \gamma) &= \frac{2}{\pi} \times \\ &\times \begin{cases} \int_0^{\pi/2} \cos((4k+1)\gamma\tau/2 \tan \phi) d\phi, & \text{если } k=0; \\ \int_0^{\pi/2} \cos\left(\phi + \right. \\ \left. + 2 \sum_{s=0}^{k-1} \arctan\left(\frac{4k+1}{4s+1} \tan \phi\right)\right) \times \\ \left. \times \frac{\cos((4k+1)\gamma\tau/2 \tan \phi)}{\cos \phi} d\phi, & \text{если } k>0. \end{cases} \end{aligned}$$

$$\begin{aligned} \text{[5.6]} \quad Leg_k(\tau, \gamma) &= \frac{2}{\pi} \times \\ &\times \begin{cases} \int_0^{\pi/2} \cos((2k+1)\gamma\tau \tan \phi) d\phi, & \text{если } k=0; \\ \int_0^{\pi/2} \cos\left(\phi + \right. \\ \left. + 2 \sum_{s=0}^{k-1} \arctan\left(\frac{2k+1}{2s+1} \tan \phi\right)\right) \times \\ \left. \times \frac{\cos((2k+1)\gamma\tau \tan \phi)}{\cos \phi} d\phi, & \text{если } k>0. \end{cases} \end{aligned}$$

$$[5.7] \quad P_k^{(1/2,0)}(\tau, \gamma) = \frac{2}{\pi} \times \begin{cases} \int_0^{\pi/2} \cos((4k+3)\gamma\tau/2 \tan \phi) d\phi, & \text{если } k=0; \\ \int_0^{\pi/2} \cos\left(\phi + \right. \\ \left. + 2 \sum_{s=0}^{k-1} \arctan\left(\frac{4k+3}{4s+3} \tan \phi\right)\right) \times \\ \left. \times \frac{\cos((4k+3)\gamma\tau/2 \tan \phi)}{\cos \phi} d\phi, \right. & \text{если } k > 0. \end{cases}$$

$$[5.8] \quad P_k^{(1,0)}(\tau, \gamma) = \frac{2}{\pi} \times \begin{cases} \int_0^{\pi/2} \cos((k+1)\gamma\tau \tan \phi) d\phi, & \text{если } k=0; \\ \int_0^{\pi/2} \cos\left(\phi + \right. \\ \left. + 2 \sum_{s=0}^{k-1} \arctan\left(\frac{k+1}{s+1} \tan \phi\right)\right) \times \\ \left. \times \frac{\cos((k+1)\gamma\tau \tan \phi)}{\cos \phi} d\phi, \right. & \text{если } k > 0. \end{cases}$$

$$[5.9] \quad P_k^{(2,0)}(\tau, \gamma) = \frac{2}{\pi} \times \begin{cases} \int_0^{\pi/2} \cos((2k+3)\gamma\tau \tan \phi) d\phi, & \text{если } k=0; \\ \int_0^{\pi/2} \cos\left(\phi + \right. \\ \left. + 2 \sum_{s=0}^{k-1} \arctan\left(\frac{2k+3}{2s+3} \tan \phi\right)\right) \times \\ \left. \times \frac{\cos((2k+3)\gamma\tau \tan \phi)}{\cos \phi} d\phi, \right. & \text{если } k > 0. \end{cases}$$

$$[5.10] \quad P_k^{(\alpha,0)}(\tau, \gamma) = \frac{2}{\pi} \times \begin{cases} \int_0^{\pi/2} \cos((2k+\alpha+1)c\gamma\tau/2 \tan \phi) d\phi, & \text{если } k=0; \\ \int_0^{\pi/2} \cos\left(\phi + 2 \times \right. \\ \left. \times \sum_{s=0}^{k-1} \arctan\left(\frac{2k+\alpha+1}{2s+\alpha+1} \tan \phi\right)\right) \times \\ \left. \times \frac{\cos((2k+\alpha+1)c\gamma\tau/2 \tan \phi)}{\cos \phi} d\phi, \right. & \text{если } k > 0. \end{cases}$$

$$[5.11] \quad P_k^{(0,1)}(\tau, \gamma) = \frac{4(k+1)}{\pi(2k+3)(1-\exp(-2\gamma\tau))} \times \begin{cases} \int_0^{\pi/2} \cos\left(\arctan\left(\frac{2k+1}{2k+3} \tan \phi\right)\right) \times \\ \times \cos\left(\phi + \arctan\left(\frac{2k+1}{2k+3} \tan \phi\right)\right) \times \\ \times \frac{\cos((2k+1)\gamma\tau \tan \phi)}{\cos \phi} d\phi, & \text{если } k=0; \\ \int_0^{\pi/2} \cos\left(\arctan\left(\frac{2k+1}{2k+3} \tan \phi\right)\right) \times \\ \times \cos\left(\phi + \arctan\left(\frac{2k+1}{2k+3} \tan \phi\right) + \right. \\ \left. + 2 \sum_{s=0}^{k-1} \arctan\left(\frac{2k+1}{2s+1} \tan \phi\right)\right) \times \\ \left. \times \frac{\cos((2k+1)\gamma\tau \tan \phi)}{\cos \phi} d\phi, \right. & \text{если } k > 0. \end{cases}$$

$$[5.12] \quad P_k^{(0,2)}(\tau, \gamma) = \frac{8(k+1)(k+2)}{(2k+3)(2k+5)(1-\exp(-2\gamma\tau))^2} \times \begin{cases} \int_0^{\pi/2} \cos\left(\arctan\left(\frac{2k+1}{2k+3} \tan \phi\right)\right) \times \\ \times \cos\left(\arctan\left(\frac{2k+1}{2k+5} \tan \phi\right)\right) \times \\ \times \cos\left(\phi + \arctan\left(\frac{2k+1}{2k+3} \tan \phi\right) + \right. \\ \left. + \arctan\left(\frac{2k+1}{2k+5} \tan \phi\right)\right) \times \\ \times \frac{\cos((2k+1)\gamma\tau \tan \phi)}{\cos \phi} d\phi, & \text{если } k=0; \\ \frac{1}{\pi} \int_0^{\pi/2} \cos\left(\arctan\left(\frac{2k+1}{2k+3} \tan \phi\right)\right) \times \\ \times \cos\left(\arctan\left(\frac{2k+1}{2k+5} \tan \phi\right)\right) \times \\ \times \cos\left(\phi + \arctan\left(\frac{2k+1}{2k+3} \tan \phi\right) + \right. \\ \left. + \arctan\left(\frac{2k+1}{2k+5} \tan \phi\right) + \right. \\ \left. + 2 \sum_{s=0}^{k-1} \arctan\left(\frac{2k+1}{2s+1} \tan \phi\right)\right) \times \\ \left. \times \frac{\cos((2k+1)\gamma\tau \tan \phi)}{\cos \phi} d\phi, \right. & \text{если } k > 0. \end{cases}$$

$$\begin{aligned}
\text{[5.13]} \quad P_k^{(0,\beta)}(\tau, \gamma) &= \\
&= \frac{2^{\beta+1}(k+\beta)!(2k+1)}{\pi k!(1-\exp(-2c\gamma\tau/2))^\beta \prod_{p=0}^{\beta} (2k+2p+1)} \times \\
&\quad \left\{ \int_0^{\pi/2} \prod_{p=0}^{\beta} \cos\left(\arctan\left(\frac{2k+1}{2k+2p+1} \tan \phi\right)\right) \times \right. \\
&\quad \times \cos\left(\phi + \right. \\
&\quad \left. + \sum_{p=0}^{\beta} \arctan\left(\frac{2k+1}{2k+2p+1} \tan \phi\right)\right) \times \\
&\quad \times \frac{\cos((2k+1)c\gamma\tau/2 \tan \phi)}{(\cos \phi)^2} d\phi, \quad k=0; \\
&\quad \times \left\{ \int_0^{\pi/2} \prod_{p=0}^{\beta} \cos\left(\arctan\left(\frac{2k+1}{2k+2p+1} \tan \phi\right)\right) \times \right. \\
&\quad \times \cos\left(\phi + \right. \\
&\quad \left. + \sum_{p=0}^{\beta} \arctan\left(\frac{2k+1}{2k+2p+1} \tan \phi\right) + \right. \\
&\quad \left. + 2 \sum_{s=0}^{k-1} \arctan\left(\frac{2k+1}{2s+1} \tan \phi\right)\right) \times \\
&\quad \times \frac{\cos((2k+1)c\gamma\tau/2 \tan \phi)}{(\cos \phi)^2} d\phi, \quad k > 0.
\end{aligned}$$



## Глава 6

# Аналитические представления в частотной области

### Определение.

Для представления ортогональных функций в частотной области имеет место ряд определений в зависимости от дальнейшего приложения. Наиболее распространено следующее определение, известное как преобразование Фурье ортогональных функций [9, 1]

$$W_k^{\{\psi_k(\tau, \gamma)\}}(j\omega) = \int_0^\infty \psi_k(\tau, \gamma) \exp(-j\omega\tau) d\tau.$$

В отличие от вышеприведенной характеристики преобразование Фурье ортогональных фильтров является физически реализуемым [6]

$$V_k^{\{\psi_k(\tau, \gamma)\}}(j\omega) = \int_0^\infty \psi_k(\tau, \gamma) \exp(-j\omega\tau) \mu^{\{\psi_k(\tau, \gamma)\}}(\tau, \gamma) d\tau.$$

Значительно реже используется определение преобразования Фурье производных ортогональных функций  $W_k^{\left\{\frac{\partial \psi_k(\tau, \gamma)}{\partial \tau}\right\}}(j\omega)$ .

### 6.1 Преобразование Фурье ортогональных функций

$$\begin{aligned} [6.1] \quad W_k^{[1]\{L_k(\tau, \gamma)\}}(j\omega) &= \\ &= \frac{1}{j\omega + \gamma/2} \sum_{s=0}^k \binom{k}{k-s} \left(\frac{-\gamma}{j\omega + \gamma/2}\right)^s. \end{aligned}$$

$$[6.2] \quad W_k^{[2]\{L_k(\tau, \gamma)\}}(j\omega) = \frac{1}{j\omega + \gamma/2} \left(\frac{j\omega - \gamma/2}{j\omega + \gamma/2}\right)^k.$$

$$\begin{aligned} [6.3] \quad W_k^{[3]\{L_k(\tau, \gamma)\}}(j\omega) &= \frac{2}{\gamma} (-1)^k \cos \varphi \times \\ &\times \exp(-j(2k+1)\varphi), \quad \varphi = \arctan \frac{2\omega}{\gamma}. \end{aligned}$$

Частные случаи для преобразования Фурье функций 0-5 порядков:

$$\begin{aligned} W_0^{\{L_0(\tau, \gamma)\}}(j\omega) &= \frac{1}{j\omega + \gamma/2}; \\ W_1^{\{L_1(\tau, \gamma)\}}(j\omega) &= \frac{j\omega - \gamma/2}{(j\omega + \gamma/2)^2}; \\ W_2^{\{L_2(\tau, \gamma)\}}(j\omega) &= \frac{(j\omega - \gamma/2)^2}{(j\omega + \gamma/2)^3}; \\ W_3^{\{L_3(\tau, \gamma)\}}(j\omega) &= \frac{(j\omega - \gamma/2)^3}{(j\omega + \gamma/2)^4}; \end{aligned}$$



Рис. 6.1. Вид преобразования Фурье ортогональных функций Лагерра 0-5 порядков;  $\gamma = 4$

[6.4] 
$$W_k^{[1]\{L_k^{(1)}(\tau, \gamma)\}}(j\omega) = \frac{1}{j\omega + \gamma/2} \sum_{s=0}^k \binom{k+1}{k-s} \left(\frac{-\gamma}{j\omega + \gamma/2}\right)^s.$$

[6.5] 
$$W_k^{[2]\{L_k^{(1)}(\tau, \gamma)\}}(j\omega) = \frac{1}{\gamma} \left(1 - \left(\frac{j\omega - \gamma/2}{j\omega + \gamma/2}\right)^{k+1}\right).$$

[6.6] 
$$W_k^{[3]\{L_k^{(1)}(\tau, \gamma)\}}(j\omega) = \frac{1}{\gamma} \left(1 + (-1)^k \exp(-j(2k+2)\varphi)\right), \quad \varphi = \arctan \frac{2\omega}{\gamma}.$$

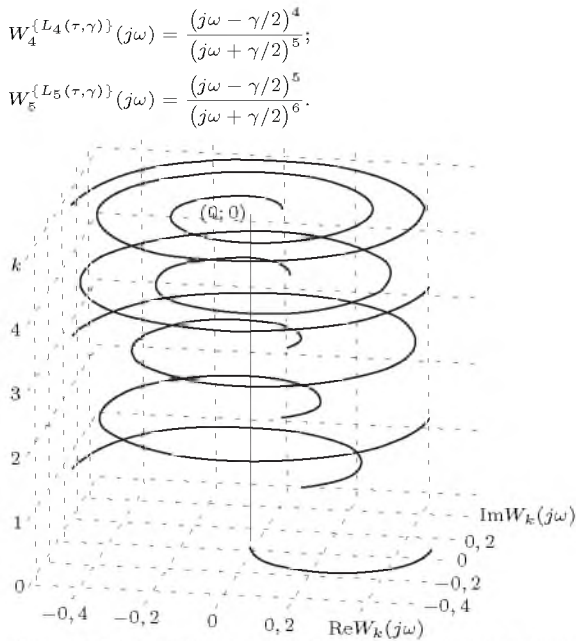
Частные случаи для преобразования Фурье функций 0-5 порядков:

$$W_0^{(L_0^{(1)}(\tau, \gamma))}(j\omega) = \frac{1}{j\omega + \gamma/2};$$

$$W_1^{(L_1^{(1)}(\tau, \gamma))}(j\omega) = \frac{2j\omega}{(j\omega + \gamma/2)^2};$$

$$W_2^{(L_2^{(1)}(\tau, \gamma))}(j\omega) = \frac{\gamma^2/4 - 3\omega^2}{(j\omega + \gamma/2)^3};$$

$$W_3^{(L_3^{(1)}(\tau, \gamma))}(j\omega) = \frac{\gamma^2 j\omega - 4j\omega^3}{(j\omega + \gamma/2)^4};$$

$$W_4^{(L_4^{(1)}(\tau, \gamma))}(j\omega) = \frac{\gamma^4/16 - 5\gamma^2\omega^2/2 + 5\omega^4}{(j\omega + \gamma/2)^5};$$

$$W_5^{(L_5^{(1)}(\tau, \gamma))}(j\omega) = \frac{3\gamma^4 j\omega/8 - 5\gamma^2 j\omega^3 + 6j\omega^4}{(j\omega + \gamma/2)^6}.$$



Рис. 6.2. Вид преобразования Фурье ортогональных функций Сонина-Лагерра 0-5 порядков;  $\gamma = 4, \alpha = 1$

[6.7] 
$$W_k^{[1]\{L_k^{(2)}(\tau, \gamma)\}}(j\omega) = \frac{1}{j\omega + \gamma/2} \sum_{s=0}^k \binom{k+2}{k-s} \left(\frac{-\gamma}{j\omega + \gamma/2}\right)^s.$$

[6.8] 
$$W_k^{[2]\{L_k^{(2)}(\tau, \gamma)\}}(j\omega) = \frac{1}{\gamma^2} \times \left[ \left( \left(\frac{j\omega - \gamma/2}{j\omega + \gamma/2}\right)^{k+1} - 1 \right) (j\omega - \gamma/2) + \gamma(k+1) \right].$$

[6.9] 
$$W_k^{[3]\{L_k^{(2)}(\tau, \gamma)\}}(j\omega) = \frac{1}{\gamma} \times \left( \frac{\exp(-j\varphi) + (-1)^k \exp(-j(2k+3)\varphi)}{2 \cos \varphi} + k + 1 \right),$$
  

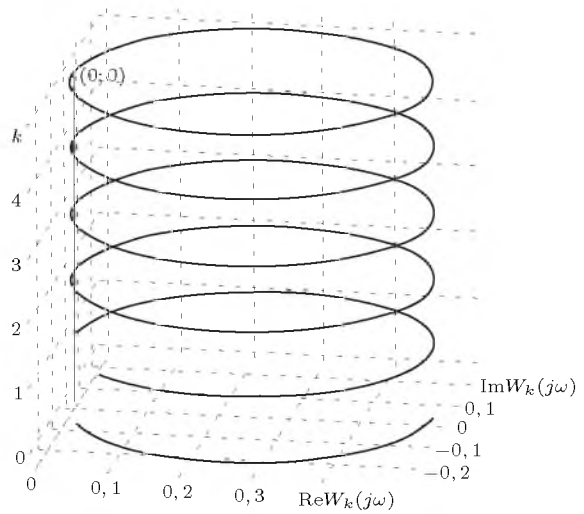
$$\varphi = \arctan \frac{2\omega}{\gamma}.$$

Частные случаи для преобразования Фурье функций 0-5 порядков:

$$W_0^{(L_0^{(2)}(\tau, \gamma))}(j\omega) = \frac{1}{j\omega + \gamma/2};$$

$$W_1^{(L_1^{(2)}(\tau, \gamma))}(j\omega) = \frac{\gamma/2 + 3j\omega}{(j\omega + \gamma/2)^2};$$

$$W_2^{(L_2^{(2)}(\tau, \gamma))}(j\omega) = \frac{\gamma^2/2 + 2\gamma j\omega - 6\omega^2}{(j\omega + \gamma/2)^3};$$

$$W_3^{(L_3^{(2)}(\tau, \gamma))}(j\omega) = \frac{\gamma^3/4 + 5\gamma^2 j\omega/2 - 5\gamma\omega^2 - 10j\omega^3}{(j\omega + \gamma/2)^4};$$

$$W_4^{(L_4^{(2)}(\tau, \gamma))}(j\omega) = \frac{1}{(j\omega + \gamma/2)^5} (3\gamma^4/16 + 3\gamma^3 j\omega/2 - 15\gamma^2\omega^2/2 - 10\gamma j\omega^3 + 15\omega^4);$$

$$W_5^{(L_5^{(2)}(\tau, \gamma))}(j\omega) = \frac{1}{(j\omega + \gamma/2)^6} (3\gamma^5/32 + 21\gamma^4 j\omega/16 - 21\gamma^3\omega^2/4 - 35\gamma^2 j\omega^3/2 + 35\gamma\omega^4/2 + 21j\omega^5).$$



Рис. 6.3. Вид преобразования Фурье ортогональных функций Сонина-Лагерра 0-5 порядков;  $\gamma = 4, \alpha = 2$

$$[6.10] \quad W_k^{[1]\{L_k^{(\alpha)}(\tau, \gamma)\}}(j\omega) = \frac{1}{j\omega + \gamma/2} \sum_{s=0}^k \binom{k+\alpha}{k-s} \left(\frac{-\gamma}{j\omega + \gamma/2}\right)^s.$$

$$[6.11] \quad W_k^{[2]\{L_k^{(\alpha)}(\tau, \gamma)\}}(j\omega) = \frac{(j\omega + \gamma/2)^{\alpha-1}}{(-\gamma)^\alpha} \left[ \left(\frac{j\omega - \gamma/2}{j\omega + \gamma/2}\right)^{k+\alpha} - \sum_{p=0}^{\alpha-1} \binom{k+\alpha}{p} \left(-\frac{\gamma}{j\omega + \gamma/2}\right)^p \right], \quad \alpha \in \mathbb{Z}.$$

Частные случаи для преобразования Фурье функций 0-5 порядков:

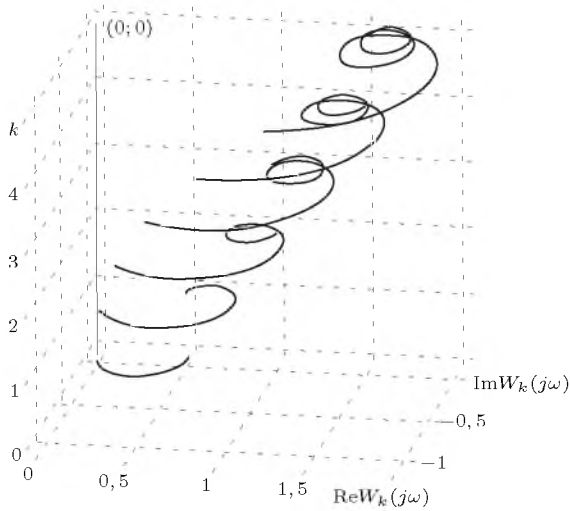
$$W_0^{\{L_0^{(\alpha)}(\tau, \gamma)\}}(j\omega) = \frac{1}{j\omega + \gamma/2};$$

$$W_1^{\{L_1^{(\alpha)}(\tau, \gamma)\}}(j\omega) = \frac{\gamma(\alpha-1)/2 + j\omega(\alpha+1)}{(j\omega + \gamma/2)^2};$$

$$W_2^{\{L_2^{(\alpha)}(\tau, \gamma)\}}(j\omega) = \frac{1}{(j\omega + \gamma/2)^3} (\gamma^2(\alpha^2 + \alpha - 2)/8 + \gamma j\omega(\alpha^2 - \alpha + 2)/2 - \omega^2(\alpha^2 + 3\alpha + 2)/2);$$

$$W_3^{\{L_3^{(\alpha)}(\tau, \gamma)\}}(j\omega) = \frac{1}{(j\omega + \gamma/2)^4} (-\gamma^3 + \gamma^2(j\omega + \gamma/2)(\alpha + 3) - \gamma(j\omega + \gamma/2)^2(\alpha + 2)(\alpha + 3)/2 - (j\omega + \gamma/2)^3(\alpha + 3)/(6\alpha!));$$

$$W_4^{\{L_4^{(\alpha)}(\tau, \gamma)\}}(j\omega) = \frac{1}{(j\omega + \gamma/2)^5} (\gamma^4 - \gamma^3(j\omega + \gamma/2)(\alpha + 4) + \gamma^2(j\omega + \gamma/2)^2(\alpha + 3)(\alpha + 4)/2 - \gamma(j\omega + \gamma/2)^3 \times (\alpha + 4)!/(6(\alpha + 1)!) + (j\omega + \gamma/2)^4(\alpha + 4)!/(24\alpha!));$$

$$W_5^{\{L_5^{(\alpha)}(\tau, \gamma)\}}(j\omega) = \frac{1}{(j\omega + \gamma/2)^6} (-\gamma^5 + \gamma^4(j\omega + \gamma/2)(\alpha + 5) - \gamma^3(j\omega + \gamma/2)^2(\alpha + 4)(\alpha + 5)/2 + \gamma^2(j\omega + \gamma/2)^3 \times (\alpha + 5)!/(6(\alpha + 2)!) - \gamma(j\omega + \gamma/2)^4(\alpha + 5)!/(24(\alpha + 1)!) + (j\omega + \gamma/2)^5(\alpha + 5)!/(120\alpha!)).$$



Рис. 6.4. Вид преобразования Фурье ортогональных функций Сонина-Лагерра 2-ого порядка: а)  $\gamma = 4, \alpha \in [0; 5]$ ; б)  $\gamma \in [1; 5], \alpha = 1$

$$[6.12] \quad W_k^{[1]\{P_k^{(-1/2, 0)}(\tau, \gamma)\}}(j\omega) = \sum_{s=0}^k \binom{k}{s} \binom{k+s-1/2}{s-1/2} (-1)^s \frac{1}{(4s+1)\gamma/2 + j\omega}.$$

$$[6.13] \quad W_k^{[2]\{P_k^{(-1/2,0)}(\tau,\gamma)\}}(j\omega) = \begin{cases} 1 \\ \gamma/2 + j\omega \end{cases} \quad \text{если } k = 0; \\ = \begin{cases} \frac{1}{(4k+1)\gamma/2 + j\omega} \times \\ \times \prod_{s=0}^{k-1} \frac{(4s+1)\gamma/2 - j\omega}{(4s+1)\gamma/2 + j\omega}, \end{cases} \quad \text{если } k > 0.$$

$$[6.14] \quad W_k^{[3]\{P_k^{(-1/2,0)}(\tau,\gamma)\}}(j\omega) = \begin{cases} \frac{2}{\gamma} \cos \varphi_0 \exp(-j\varphi_0), \\ \frac{1}{(4k+1)\gamma} \cos \varphi_k \times \\ \times \exp\left(-j\left(\varphi_k + 2 \sum_{s=0}^{k-1} \varphi_s\right)\right), \end{cases} \quad \text{если } k = 0; \\ \text{если } k > 0, \\ \varphi_k = \arctan \frac{2\omega}{(4k+1)\gamma}.$$

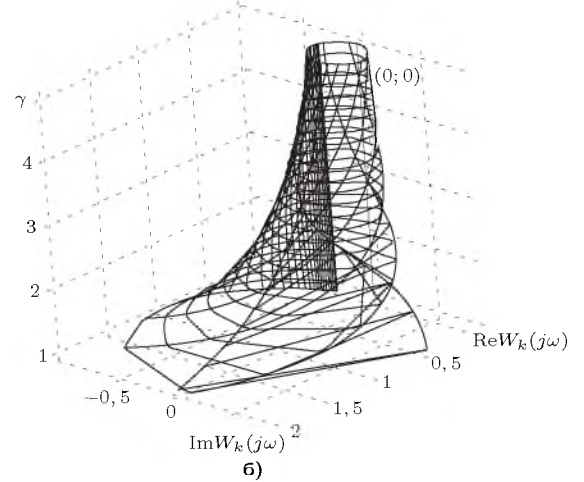
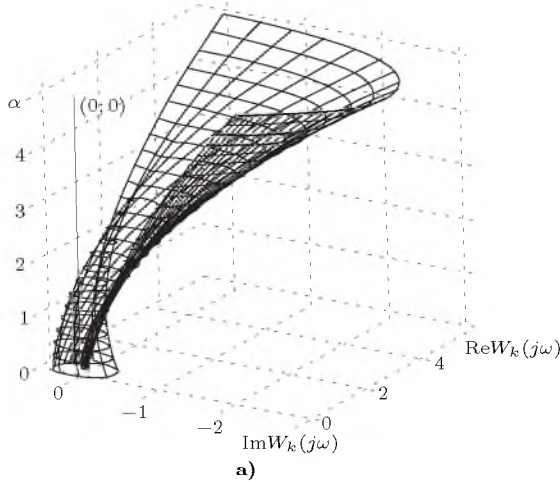
Частные случаи для преобразования Фурье функций 0-5 порядков:

$$W_0^{\{P_0^{(-1/2,0)}(\tau,\gamma)\}}(j\omega) = \frac{1}{\gamma/2 + j\omega}; \\ W_1^{\{P_1^{(-1/2,0)}(\tau,\gamma)\}}(j\omega) = \frac{\gamma/2 - j\omega}{(\gamma/2 + j\omega)(5\gamma/2 + j\omega)}; \\ W_2^{\{P_2^{(-1/2,0)}(\tau,\gamma)\}}(j\omega) = \frac{(\gamma/2 - j\omega)(5\gamma/2 - j\omega)}{(\gamma/2 + j\omega)(5\gamma/2 + j\omega)(9\gamma/2 + j\omega)}; \\ W_3^{\{P_3^{(-1/2,0)}(\tau,\gamma)\}}(j\omega) = \frac{1}{(13\gamma/2 + j\omega)} \frac{(\gamma/2 - j\omega)}{(\gamma/2 + j\omega)} \times \\ \times \frac{(5\gamma/2 - j\omega)(9\gamma/2 - j\omega)}{(5\gamma/2 + j\omega)(9\gamma/2 + j\omega)}; \\ W_4^{\{P_4^{(-1/2,0)}(\tau,\gamma)\}}(j\omega) = \frac{1}{(17\gamma/2 + j\omega)} \frac{(\gamma/2 - j\omega)}{(\gamma/2 + j\omega)} \times \\ \times \frac{(5\gamma/2 - j\omega)(9\gamma/2 - j\omega)(13\gamma/2 - j\omega)}{(5\gamma/2 + j\omega)(9\gamma/2 + j\omega)(13\gamma/2 + j\omega)}; \\ W_5^{\{P_5^{(-1/2,0)}(\tau,\gamma)\}}(j\omega) = \frac{1}{(21\gamma/2 + j\omega)} \frac{(\gamma/2 - j\omega)}{(\gamma/2 + j\omega)} \times \\ \times \frac{(5\gamma/2 - j\omega)(9\gamma/2 - j\omega)(13\gamma/2 - j\omega)(17\gamma/2 - j\omega)}{(5\gamma/2 + j\omega)(9\gamma/2 + j\omega)(13\gamma/2 + j\omega)(17\gamma/2 + j\omega)}.$$



Рис. 6.5. Вид преобразования Фурье ортогональных функций Якоби 0-5 порядков;  $\gamma = 1$ ,  $c = 2$ ,  $\alpha = -1/2$ ,  $\beta = 0$

$$[6.15] \quad W_k^{[1]\{Leg_k(\tau,\gamma)\}}(j\omega) = \sum_{s=0}^k \binom{k}{s} \binom{k+s}{s} (-1)^s \frac{1}{(2s+1)\gamma + j\omega}.$$

$$[6.16] \quad W_k^{[2]\{Leg_k(\tau,\gamma)\}}(j\omega) = \begin{cases} 1 \\ \gamma + j\omega \end{cases} \quad \text{если } k = 0; \\ = \frac{1}{(2k+1)\gamma + j\omega} \prod_{s=0}^{k-1} \frac{(2s+1)\gamma - j\omega}{(2s+1)\gamma + j\omega}, \quad \text{если } k > 0.$$

$$[6.17] \quad W_k^{[3]\{Leg_k(\tau,\gamma)\}}(j\omega) = \begin{cases} \frac{1}{\gamma} \cos \varphi_0 \exp(-j\varphi_0), \\ \frac{1}{(2k+1)\gamma} \cos \varphi_k \times \\ \times \exp\left(-j\left(\varphi_k + 2 \sum_{s=0}^{k-1} \varphi_s\right)\right), \end{cases} \quad \text{если } k = 0; \\ \text{если } k > 0, \\ \varphi_k = \arctan \frac{\omega}{(2k+1)\gamma}.$$

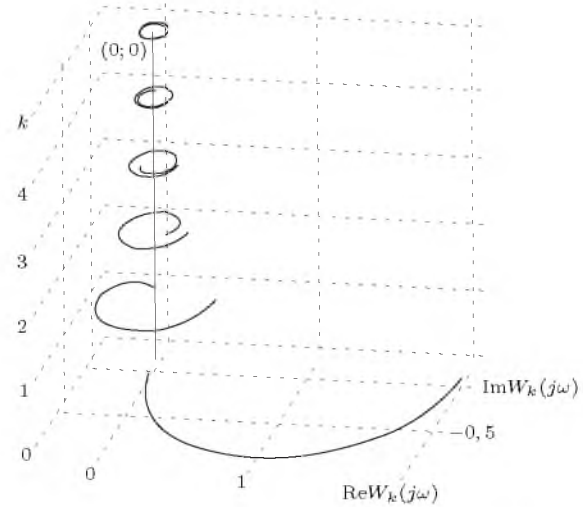
Частные случаи для преобразования Фурье функций 0-5 порядков:

$$W_0^{\{Leg_0(\tau,\gamma)\}}(j\omega) = \frac{1}{\gamma + j\omega}; \\ W_1^{\{Leg_1(\tau,\gamma)\}}(j\omega) = \frac{\gamma - j\omega}{(\gamma + j\omega)(3\gamma + j\omega)}; \\ W_2^{\{Leg_2(\tau,\gamma)\}}(j\omega) = \frac{(\gamma - j\omega)(3\gamma - j\omega)}{(\gamma + j\omega)(3\gamma + j\omega)(5\gamma + j\omega)}; \\ W_3^{\{Leg_3(\tau,\gamma)\}}(j\omega) = \frac{(\gamma - j\omega)(3\gamma - j\omega)(5\gamma - j\omega)}{(\gamma + j\omega)(3\gamma + j\omega)(5\gamma + j\omega)(7\gamma + j\omega)}; \\ W_4^{\{Leg_4(\tau,\gamma)\}}(j\omega) = \frac{1}{(9\gamma + j\omega)} \frac{(\gamma - j\omega)(3\gamma - j\omega)}{(\gamma + j\omega)(3\gamma + j\omega)} \times \\ \times \frac{(5\gamma - j\omega)(7\gamma - j\omega)}{(5\gamma + j\omega)(7\gamma + j\omega)};$$



$$W_5^{\{Legs(\tau, \gamma)\}}(j\omega) = \frac{1}{(11\gamma + j\omega)(\gamma + j\omega)(3\gamma + j\omega)} \times \frac{(\gamma - j\omega)(3\gamma - j\omega)}{(5\gamma - j\omega)(7\gamma - j\omega)(9\gamma - j\omega)} \times \frac{(5\gamma + j\omega)(7\gamma + j\omega)(9\gamma + j\omega)}{(5\gamma + j\omega)(7\gamma + j\omega)(9\gamma + j\omega)}$$



Рис. 6.6. Вид преобразования Фурье ортогональных функций Лежандра 0-5 порядков;  $\gamma = 1, c = 2$

[6.18] 
$$W_k^{\{1\}[P_k^{(1/2, 0)}(\tau, \gamma)]}(j\omega) = \sum_{s=0}^k \binom{k}{s} \binom{k+s+1/2}{s+1/2} (-1)^s \frac{1}{(4s+3)\gamma/2 + j\omega}$$

[6.19] 
$$W_k^{\{2\}[P_k^{(1/2, 0)}(\tau, \gamma)]}(j\omega) = \begin{cases} \frac{1}{3\gamma/2 + j\omega}, & \text{если } k = 0; \\ \frac{(4k+3)\gamma/2 + j\omega}{\prod_{s=0}^{k-1} (4s+3)\gamma/2 + j\omega}, & \text{если } k > 0. \end{cases}$$

[6.20] 
$$W_k^{\{3\}[P_k^{(1/2, 0)}(\tau, \gamma)]}(j\omega) = \begin{cases} \frac{2}{3\gamma} \cos \varphi_0 \exp(-j\varphi_0), & \text{если } k = 0; \\ \frac{(4k+3)\gamma}{2} \cos \varphi_k \times \exp\left(-j\left(\varphi_k + 2 \sum_{s=0}^{k-1} \varphi_s\right)\right), & \text{если } k > 0, \end{cases}$$
  

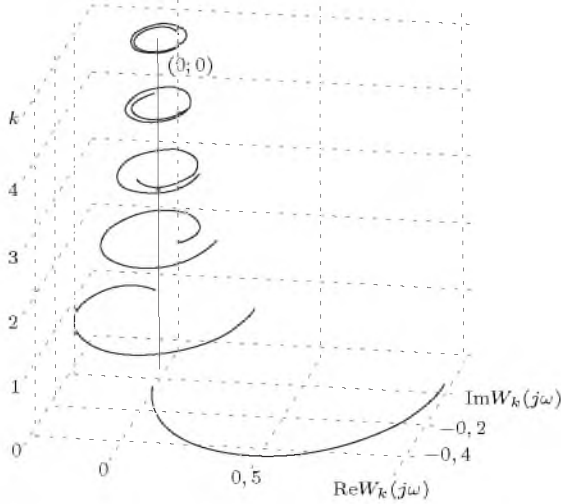
$$\varphi_k = \arctan \frac{2\omega}{(4k+3)\gamma}$$

Частные случаи для преобразования Фурье функций 0-5 порядков:

$$W_0^{\{P_0^{(1/2, 0)}(\tau, \gamma)\}}(j\omega) = \frac{1}{3\gamma/2 + j\omega};$$

$$W_1^{\{P_1^{(1/2, 0)}(\tau, \gamma)\}}(j\omega) = \frac{3\gamma/2 - j\omega}{(3\gamma/2 + j\omega)(7\gamma/2 + j\omega)};$$

$$W_2^{\{P_2^{(1/2, 0)}(\tau, \gamma)\}}(j\omega) = \frac{(3\gamma/2 - j\omega)(7\gamma/2 - j\omega)}{(3\gamma/2 + j\omega)(7\gamma/2 + j\omega)(11\gamma/2 + j\omega)};$$

$$W_3^{\{P_3^{(1/2, 0)}(\tau, \gamma)\}}(j\omega) = \frac{1}{(15\gamma/2 + j\omega)(3\gamma/2 + j\omega)} \times \frac{(7\gamma/2 - j\omega)(11\gamma/2 - j\omega)}{(7\gamma/2 + j\omega)(11\gamma/2 + j\omega)};$$

$$W_4^{\{P_4^{(1/2, 0)}(\tau, \gamma)\}}(j\omega) = \frac{1}{(19\gamma/2 + j\omega)(3\gamma/2 + j\omega)} \times \frac{(7\gamma/2 - j\omega)(11\gamma/2 - j\omega)(15\gamma/2 - j\omega)}{(7\gamma/2 + j\omega)(11\gamma/2 + j\omega)(15\gamma/2 + j\omega)};$$

$$W_5^{\{P_5^{(1/2, 0)}(\tau, \gamma)\}}(j\omega) = \frac{1}{(23\gamma/2 + j\omega)(3\gamma/2 + j\omega)} \times \frac{(7\gamma/2 - j\omega)(11\gamma/2 - j\omega)(15\gamma/2 - j\omega)(19\gamma/2 - j\omega)}{(7\gamma/2 + j\omega)(11\gamma/2 + j\omega)(15\gamma/2 + j\omega)(19\gamma/2 + j\omega)}$$



Рис. 6.7. Вид преобразования Фурье ортогональных функций Якоби 0-5 порядков;  $\gamma = 1, c = 2, \alpha = 1/2, \beta = 0$

[6.21] 
$$W_k^{\{1\}[P_k^{(1, 0)}(\tau, \gamma)]}(j\omega) = \sum_{s=0}^k \binom{k}{s} \binom{k+s+1}{s+1} (-1)^s \frac{1}{(s+1)\gamma + j\omega}$$

[6.22] 
$$W_k^{\{2\}[P_k^{(1, 0)}(\tau, \gamma)]}(j\omega) = \begin{cases} \frac{1}{\gamma + j\omega}, & \text{если } k = 0; \\ \frac{1}{(k+1)\gamma + j\omega} \prod_{s=0}^{k-1} \frac{(s+1)\gamma - j\omega}{(s+1)\gamma + j\omega}, & \text{если } k > 0. \end{cases}$$

$$[6.23] \quad W_k^{[3]\{P_k^{(1,0)}(\tau,\gamma)\}}(j\omega) = \begin{cases} \frac{1}{\gamma} \cos \varphi_0 \exp(-j\varphi_0), & \text{если } k = 0; \\ \frac{1}{(k+1)\gamma} \cos \varphi_k \times \\ \times \exp\left(-j\left(\varphi_k + 2 \sum_{s=0}^{k-1} \varphi_s\right)\right), & \text{если } k > 0, \end{cases}$$

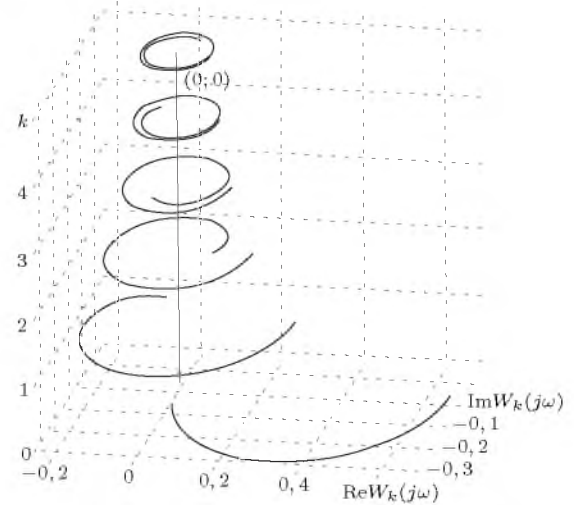
$$\varphi_k = \arctan \frac{\omega}{(k+1)\gamma}.$$

Частные случаи для преобразования Фурье функций 0-5 порядков:

$$W_0^{\{P_0^{(1,0)}(\tau,\gamma)\}}(j\omega) = \frac{1}{\gamma + j\omega};$$

$$W_1^{\{P_1^{(1,0)}(\tau,\gamma)\}}(j\omega) = \frac{\gamma - j\omega}{(\gamma + j\omega)(2\gamma + j\omega)};$$

$$W_2^{\{P_2^{(1,0)}(\tau,\gamma)\}}(j\omega) = \frac{(\gamma - j\omega)(2\gamma - j\omega)}{(\gamma + j\omega)(2\gamma + j\omega)(3\gamma + j\omega)};$$

$$W_3^{\{P_3^{(1,0)}(\tau,\gamma)\}}(j\omega) = \frac{(\gamma - j\omega)(2\gamma - j\omega)(3\gamma - j\omega)}{(\gamma + j\omega)(2\gamma + j\omega)(3\gamma + j\omega)(4\gamma + j\omega)};$$

$$W_4^{\{P_4^{(1,0)}(\tau,\gamma)\}}(j\omega) = \frac{1}{(5\gamma + j\omega)} \frac{(\gamma - j\omega)(2\gamma - j\omega)(3\gamma - j\omega)}{(\gamma + j\omega)(2\gamma + j\omega)(3\gamma + j\omega)} \times \frac{(4\gamma - j\omega)}{(4\gamma + j\omega)};$$

$$W_5^{\{P_5^{(1,0)}(\tau,\gamma)\}}(j\omega) = \frac{1}{(6\gamma + j\omega)} \frac{(\gamma - j\omega)(2\gamma - j\omega)(3\gamma - j\omega)}{(\gamma + j\omega)(2\gamma + j\omega)(3\gamma + j\omega)} \times \frac{(4\gamma - j\omega)(5\gamma - j\omega)}{(4\gamma + j\omega)(5\gamma + j\omega)}.$$



Рис. 6.8. Вид преобразования Фурье ортогональных функций Якоби 0-5 порядков;  $\gamma = 1, c = 1, \alpha = 1, \beta = 0$

$$[6.24] \quad W_k^{[1]\{P_k^{(2,0)}(\tau,\gamma)\}}(j\omega) = \sum_{s=0}^k \binom{k}{s} \binom{k+s+2}{s+2} (-1)^s \frac{1}{(2s+3)\gamma + j\omega}.$$

$$[6.25] \quad W_k^{[2]\{P_k^{(2,0)}(\tau,\gamma)\}}(j\omega) = \begin{cases} \frac{1}{3\gamma + j\omega}, & \text{если } k = 0; \\ \frac{1}{(2k+3)\gamma + j\omega} \prod_{s=0}^{k-1} \frac{(2s+3)\gamma - j\omega}{(2s+3)\gamma + j\omega}, & \text{если } k > 0. \end{cases}$$

$$[6.26] \quad W_k^{[3]\{P_k^{(2,0)}(\tau,\gamma)\}}(j\omega) = \begin{cases} \frac{1}{3\gamma} \cos \varphi_0 \exp(-j\varphi_0), & \text{если } k = 0; \\ \frac{1}{(2k+3)\gamma} \cos \varphi_k \times \\ \times \exp\left(-j\left(\varphi_k + 2 \sum_{s=0}^{k-1} \varphi_s\right)\right), & \text{если } k > 0, \end{cases}$$

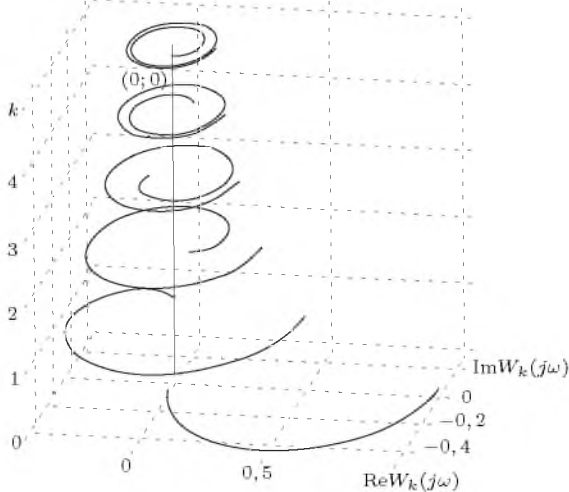
$$\varphi_k = \arctan \frac{\omega}{(2k+3)\gamma}.$$

Частные случаи для преобразования Фурье функций 0-5 порядков:

$$W_0^{\{P_0^{(2,0)}(\tau,\gamma)\}}(j\omega) = \frac{1}{3\gamma + j\omega};$$

$$W_1^{\{P_1^{(2,0)}(\tau,\gamma)\}}(j\omega) = \frac{3\gamma - j\omega}{(3\gamma + j\omega)(5\gamma + j\omega)};$$

$$W_2^{\{P_2^{(2,0)}(\tau,\gamma)\}}(j\omega) = \frac{(3\gamma - j\omega)(5\gamma - j\omega)}{(3\gamma + j\omega)(5\gamma + j\omega)(7\gamma + j\omega)};$$

$$W_3^{\{P_3^{(2,0)}(\tau,\gamma)\}}(j\omega) = \frac{1}{(9\gamma + j\omega)} \frac{(3\gamma - j\omega)(5\gamma - j\omega)(7\gamma - j\omega)}{(3\gamma + j\omega)(5\gamma + j\omega)(7\gamma + j\omega)};$$

$$W_4^{\{P_4^{(2,0)}(\tau,\gamma)\}}(j\omega) = \frac{1}{(11\gamma + j\omega)} \frac{(3\gamma - j\omega)(5\gamma - j\omega)}{(3\gamma + j\omega)(5\gamma + j\omega)} \times \frac{(7\gamma - j\omega)(9\gamma - j\omega)}{(7\gamma + j\omega)(9\gamma + j\omega)};$$

$$W_5^{\{P_5^{(2,0)}(\tau,\gamma)\}}(j\omega) = \frac{1}{(13\gamma + j\omega)} \frac{(3\gamma - j\omega)(5\gamma - j\omega)}{(3\gamma + j\omega)(5\gamma + j\omega)} \times \frac{(7\gamma - j\omega)(9\gamma - j\omega)(11\gamma - j\omega)}{(7\gamma + j\omega)(9\gamma + j\omega)(11\gamma + j\omega)}.$$



Рис. 6.9. Вид преобразования Фурье ортогональных функций Якоби 0-5 порядков;  $\gamma = 1, c = 2, \alpha = 2, \beta = 0$

$$[6.27] \quad W_k^{[1]\{P_k^{(\alpha,0)}(\tau,\gamma)\}}(j\omega) = \sum_{s=0}^k \binom{k}{s} \binom{k+s+\alpha}{s+\alpha} (-1)^s \frac{1}{(2s+\alpha+1)c\gamma/2+j\omega}.$$

$$[6.28] \quad W_k^{[2]\{P_k^{(\alpha,0)}(\tau,\gamma)\}}(j\omega) = \begin{cases} \frac{1}{(\alpha+1)c\gamma/2+j\omega}, & \text{если } k=0; \\ \frac{1}{(2k+\alpha+1)c\gamma/2+j\omega} \times \\ \times \prod_{s=0}^{k-1} \frac{(2s+\alpha+1)c\gamma/2-j\omega}{(2s+\alpha+1)c\gamma/2+j\omega}, & \text{если } k>0. \end{cases}$$

$$[6.29] \quad W_k^{[3]\{P_k^{(\alpha,0)}(\tau,\gamma)\}}(j\omega) = \begin{cases} \frac{2}{(\alpha+1)c\gamma} \cos \varphi_0 \exp(-j\varphi_0), & \text{если } k=0; \\ \frac{2}{(2k+\alpha+1)c\gamma} \cos \varphi_k \times \\ \times \exp\left(-j\left(\varphi_k + 2 \sum_{s=0}^{k-1} \varphi_s\right)\right), & \text{если } k>0, \end{cases}$$

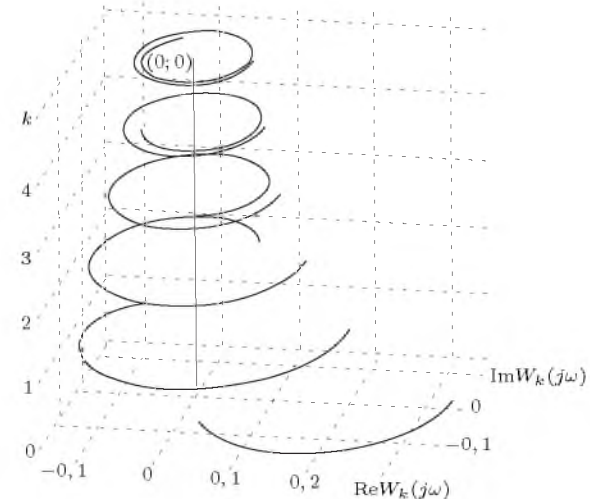
$$\varphi_k = \arctan \frac{2\omega}{(2k+\alpha+1)c\gamma}.$$

Частные случаи для преобразования Фурье функций 0-5 порядков:

$$W_0^{[P_0^{(\alpha,0)}(\tau,\gamma)]}(j\omega) = \frac{1}{(\alpha+1)c\gamma/2+j\omega};$$

$$W_1^{[P_1^{(\alpha,0)}(\tau,\gamma)]}(j\omega) = \frac{(\alpha+1)c\gamma/2-j\omega}{((\alpha+1)c\gamma/2+j\omega)((\alpha+3)c\gamma/2+j\omega)};$$

$$W_2^{[P_2^{(\alpha,0)}(\tau,\gamma)]}(j\omega) = \frac{1}{((\alpha+5)c\gamma/2+j\omega)} \frac{((\alpha+1)c\gamma/2-j\omega)}{((\alpha+1)c\gamma/2+j\omega)} \times \frac{((\alpha+3)c\gamma/2-j\omega)}{((\alpha+3)c\gamma/2+j\omega)};$$

$$W_3^{[P_3^{(\alpha,0)}(\tau,\gamma)]}(j\omega) = \frac{1}{((\alpha+7)c\gamma/2+j\omega)} \frac{((\alpha+1)c\gamma/2-j\omega)}{((\alpha+1)c\gamma/2+j\omega)} \times \frac{((\alpha+3)c\gamma/2-j\omega)((\alpha+5)c\gamma/2-j\omega)}{((\alpha+3)c\gamma/2+j\omega)((\alpha+5)c\gamma/2+j\omega)};$$

$$W_4^{[P_4^{(\alpha,0)}(\tau,\gamma)]}(j\omega) = \frac{1}{((\alpha+9)c\gamma/2+j\omega)} \frac{((\alpha+1)c\gamma/2-j\omega)}{((\alpha+7)c\gamma/2+j\omega)} \times \frac{((\alpha+3)c\gamma/2-j\omega)((\alpha+5)c\gamma/2-j\omega)((\alpha+7)c\gamma/2-j\omega)}{((\alpha+3)c\gamma/2+j\omega)((\alpha+5)c\gamma/2+j\omega)((\alpha+7)c\gamma/2+j\omega)};$$

$$W_5^{[P_5^{(\alpha,0)}(\tau,\gamma)]}(j\omega) = \frac{1}{((\alpha+11)c\gamma/2+j\omega)} \frac{((\alpha+1)c\gamma/2-j\omega)}{((\alpha+1)c\gamma/2+j\omega)} \times \frac{((\alpha+3)c\gamma/2-j\omega)((\alpha+5)c\gamma/2-j\omega)((\alpha+7)c\gamma/2-j\omega)}{((\alpha+3)c\gamma/2+j\omega)((\alpha+5)c\gamma/2+j\omega)((\alpha+7)c\gamma/2+j\omega)} \times \frac{((\alpha+9)c\gamma/2-j\omega)}{((\alpha+9)c\gamma/2+j\omega)}.$$



Рис. 6.10. Вид преобразования Фурье ортогональных функций Якоби 2-ого порядка: а)  $\gamma = 1, c = 2, \alpha \in [0; 5], \beta = 0$ ; б)  $\gamma \in [1; 3, 5], c = 2, \alpha = 1, \beta = 0$

$$[6.30] \quad W_k^{[1]\{P_k^{(0,1)}(\tau,\gamma)\}}(j\omega) = \sum_{s=0}^k \binom{k}{s} \binom{k+s+1}{s} (-1)^s \frac{1}{(2s+1)\gamma+j\omega}.$$

$$[6.31] \quad W_k^{[2]\{P_k^{(0,1)}(\tau,\gamma)\}}(j\omega) = \sum_{s=0}^k \binom{k}{s} \binom{k+s+1}{s} \times (-1)^s \frac{\cos \varphi_s \exp(-j\varphi_s)}{(2s+1)\gamma}, \quad \varphi_k = \arctan \frac{\omega}{(2k+1)\gamma}.$$

Частные случаи для преобразования Фурье функций 0-5 порядков:

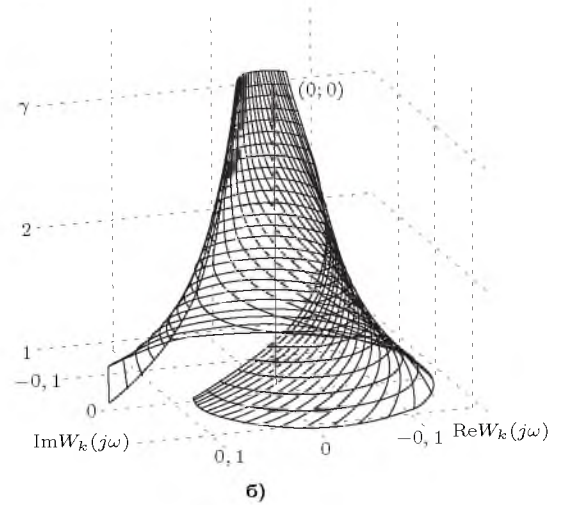
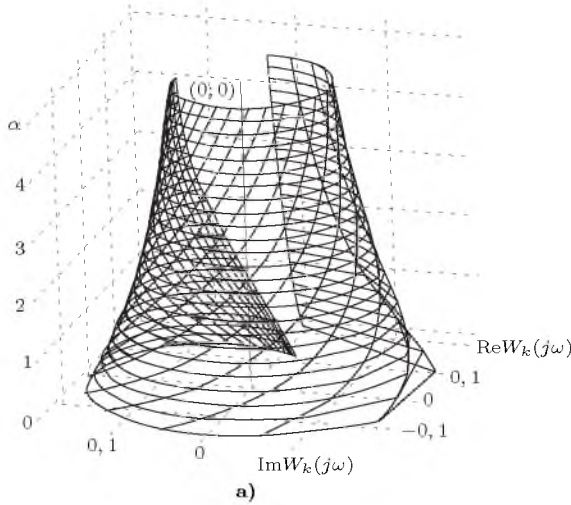
$$W_0^{[P_0^{(0,1)}(\tau,\gamma)]}(j\omega) = \frac{1}{\gamma+j\omega};$$



Рис. 6.11. Вид преобразования Фурье ортогональных функций Якоби 0-5 порядков;  $\gamma = 1, c = 2, \alpha = 0, \beta = 1$

[6.32]  $W_k^{\{1\}\{P_k^{(0,2)}(\tau,\gamma)\}}(j\omega) = \sum_{s=0}^k \binom{k}{s} \binom{k+s+2}{s} (-1)^s \frac{1}{(2s+1)\gamma + j\omega}.$

[6.33]  $W_k^{\{2\}\{P_k^{(0,2)}(\tau,\gamma)\}}(j\omega) = \sum_{s=0}^k \binom{k}{s} \binom{k+s+2}{s} \times (-1)^s \frac{\cos \varphi_s \exp(-j\varphi_s)}{(2s+1)\gamma}, \quad \varphi_k = \arctan \frac{\omega}{(2k+1)\gamma}.$

Частные случаи для преобразования Фурье функций 0-5 порядков:

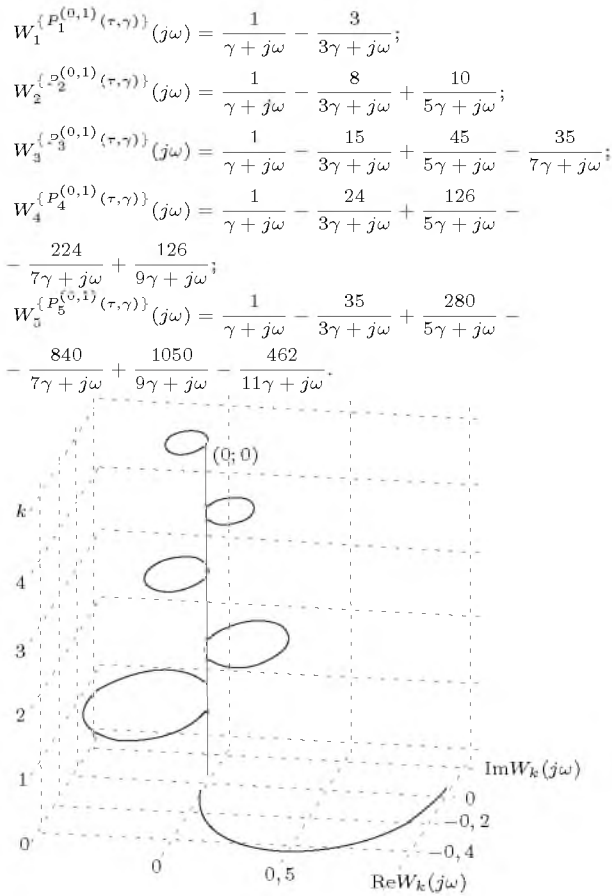
$$W_0^{\{P_0^{(0,2)}(\tau,\gamma)\}}(j\omega) = \frac{1}{\gamma + j\omega};$$

$$W_1^{\{P_1^{(0,2)}(\tau,\gamma)\}}(j\omega) = \frac{1}{\gamma + j\omega} - \frac{4}{3\gamma + j\omega};$$

$$W_2^{\{P_2^{(0,2)}(\tau,\gamma)\}}(j\omega) = \frac{1}{\gamma + j\omega} - \frac{10}{3\gamma + j\omega} + \frac{15}{5\gamma + j\omega};$$

$$W_3^{\{P_3^{(0,2)}(\tau,\gamma)\}}(j\omega) = \frac{1}{\gamma + j\omega} - \frac{18}{3\gamma + j\omega} + \frac{63}{5\gamma + j\omega} - \frac{56}{7\gamma + j\omega};$$

$$W_4^{\{P_4^{(0,2)}(\tau,\gamma)\}}(j\omega) = \frac{1}{\gamma + j\omega} - \frac{28}{3\gamma + j\omega} + \frac{168}{5\gamma + j\omega} - \frac{336}{7\gamma + j\omega} + \frac{210}{9\gamma + j\omega};$$

$$W_5^{\{P_5^{(0,2)}(\tau,\gamma)\}}(j\omega) = \frac{1}{\gamma + j\omega} - \frac{40}{3\gamma + j\omega} + \frac{360}{5\gamma + j\omega} - \frac{1200}{7\gamma + j\omega} + \frac{1650}{9\gamma + j\omega} - \frac{792}{11\gamma + j\omega}.$$



Рис. 6.12. Вид преобразования Фурье ортогональных функций Якоби 0-5 порядков;  $\gamma = 1, c = 2, \alpha = 0, \beta = 2$

[6.34]  $W_k^{\{1\}\{P_k^{(0,\beta)}(\tau,\gamma)\}}(j\omega) = \sum_{s=0}^k \binom{k}{s} \binom{k+s+\beta}{s} (-1)^s \frac{1}{(2s+1)c\gamma/2 + j\omega}.$

[6.35]  $W_k^{\{2\}\{P_k^{(0,\beta)}(\tau,\gamma)\}}(j\omega) = \sum_{s=0}^k \binom{k}{s} \binom{k+s+\beta}{s} \times (-1)^s \frac{\cos \varphi_s \exp(-j\varphi_s)}{(2s+1)c\gamma/2}, \quad \varphi_k = \arctan \frac{2\omega}{(2k+1)c\gamma}.$

Частные случаи для преобразования Фурье функций 0-5 порядков:

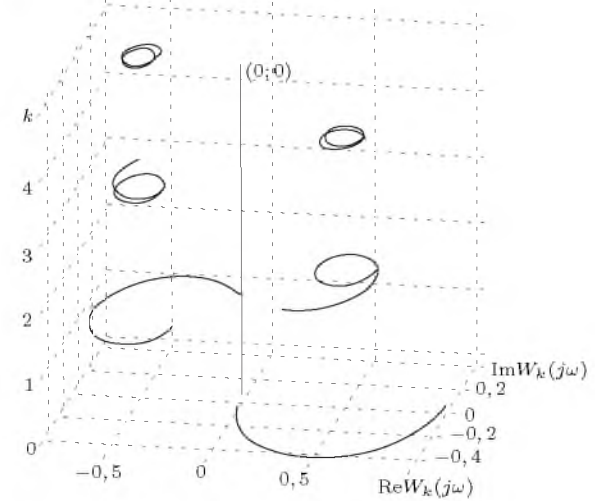
$$W_0^{\{P_0^{(0,\beta)}(\tau,\gamma)\}}(j\omega) = \frac{1}{c\gamma/2 + j\omega};$$

$$W_1^{\{P_1^{(0,\beta)}(\tau,\gamma)\}}(j\omega) = \frac{1}{c\gamma/2 + j\omega} - \frac{\beta+2}{3c\gamma/2 + j\omega};$$

$$W_2^{\{P_2^{(0,\beta)}(\tau,\gamma)\}}(j\omega) = \frac{1}{c\gamma/2 + j\omega} - \frac{2(\beta+3)}{3c\gamma/2 + j\omega} + \frac{(\beta+3)(\beta+4)/2}{5c\gamma/2 + j\omega};$$

$$W_3^{\{P_3^{(0,\beta)}(\tau,\gamma)\}}(j\omega) = \frac{1}{c\gamma/2 + j\omega} - \frac{3(\beta+4)}{3c\gamma/2 + j\omega} + \frac{3(\beta+4)(\beta+5)/2}{5c\gamma/2 + j\omega} - \frac{(\beta+4)(\beta+5)(\beta+6)/6}{7c\gamma/2 + j\omega};$$

$$W_4^{\{P_4^{(0,\beta)}(\tau,\gamma)\}}(j\omega) = \frac{1}{c\gamma/2 + j\omega} - \frac{4(\beta+5)}{3c\gamma/2 + j\omega} + \frac{3(\beta+5)(\beta+6)}{5c\gamma/2 + j\omega} - \frac{2(\beta+5)(\beta+6)(\beta+7)/3}{7c\gamma/2 + j\omega} +$$

$$W_5^{(P_5^{(0,\beta)})(\tau,\gamma)}(j\omega) = \frac{1}{c\gamma/2 + j\omega} - \frac{5(\beta + 6)}{3c\gamma/2 + j\omega} +$$

$$+ \frac{5(\beta + 6)(\beta + 7)}{5c\gamma/2 + j\omega} - \frac{5(\beta + 6)(\beta + 7)(\beta + 8)/3}{7c\gamma/2 + j\omega} +$$

$$+ \frac{5(\beta + 9)!}{24(\beta + 5)!(9c\gamma/2 + j\omega)} - \frac{(\beta + 10)!}{120(\beta + 5)!(11c\gamma/2 + j\omega)}.$$



Рис. 6.13. Вид преобразования Фурье ортогональных функций Якоби 2-ого порядка: а)  $\gamma = 1, c = 2, \alpha = 0, \beta \in [0; 5]$ ; б)  $\gamma \in [1; 3, 5], c = 2, \alpha = 0, \beta = 1$

### 6.2 Преобразование Фурье ортогональных фильтров

[6.36]  $V_k^{[1]\{L_k(\tau,\gamma)\}}(j\omega) = \frac{\gamma}{j\omega + \gamma/2} \sum_{s=0}^k \binom{k}{k-s} \left(\frac{-\gamma}{j\omega + \gamma/2}\right)^s.$

[6.37]  $V_k^{[2]\{L_k(\tau,\gamma)\}}(j\omega) = \frac{\gamma}{j\omega + \gamma/2} \left(\frac{j\omega - \gamma/2}{j\omega + \gamma/2}\right)^k.$

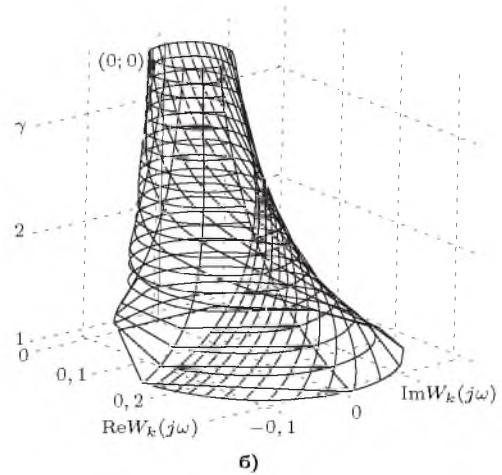
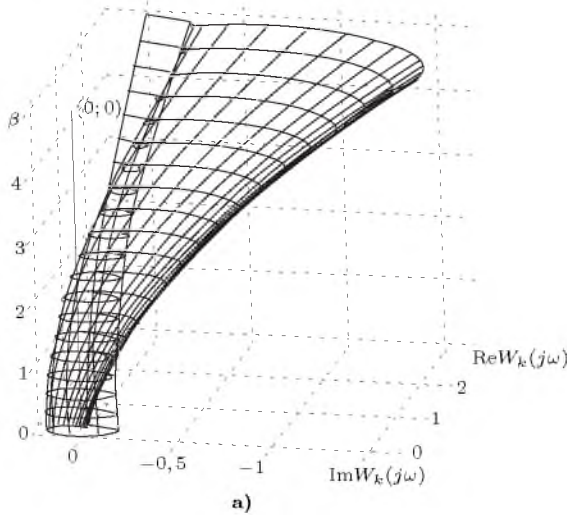
[6.38]  $V_k^{[3]\{L_k(\tau,\gamma)\}}(j\omega) = 2(-1)^k \cos \varphi \times \exp(-j(2k + 1)\varphi), \quad \varphi = \arctan \frac{2\omega}{\gamma}.$

Частные случаи для преобразования Фурье фильтров 0-5 порядков:

$$V_0^{(L_0(\tau,\gamma))}(j\omega) = \frac{\gamma}{j\omega + \gamma/2};$$

$$V_1^{(L_1(\tau,\gamma))}(j\omega) = \frac{\gamma(j\omega - \gamma/2)}{(j\omega + \gamma/2)^2};$$

$$V_2^{(L_2(\tau,\gamma))}(j\omega) = \frac{\gamma(j\omega - \gamma/2)^2}{(j\omega + \gamma/2)^3};$$

$$V_3^{(L_3(\tau,\gamma))}(j\omega) = \frac{\gamma(j\omega - \gamma/2)^3}{(j\omega + \gamma/2)^4};$$

$$V_4^{(L_4(\tau,\gamma))}(j\omega) = \frac{\gamma(j\omega - \gamma/2)^4}{(j\omega + \gamma/2)^5};$$

$$V_5^{(L_5(\tau,\gamma))}(j\omega) = \frac{\gamma(j\omega - \gamma/2)^5}{(j\omega + \gamma/2)^6}.$$



Рис. 6.14. Вид преобразования Фурье ортогональных фильтров Лагерра 0-5 порядков;  $\gamma = 4$

[6.39]  $V_k^{[1]\{L_k^{(1)}(\tau,\gamma)\}}(j\omega) = \frac{\gamma^2}{(j\omega + \gamma/2)^2} \sum_{s=0}^k \binom{k}{k-s} \left(\frac{-\gamma}{j\omega + \gamma/2}\right)^s,$

[6.40]  $V_k^{[2]\{L_k^{(1)}(\tau,\gamma)\}}(j\omega) = \frac{\gamma^2}{(j\omega + \gamma/2)^2} \left(\frac{j\omega - \gamma/2}{j\omega + \gamma/2}\right)^k.$

$$[6.41] \quad V_k^{[3]\{L_k^{(1)}(\tau, \gamma)\}}(j\omega) = 4(-1)^k (\cos \varphi)^2 \times \\ \times \exp(-j(2k+2)\varphi), \quad \varphi = \arctan \frac{2\omega}{\gamma}.$$

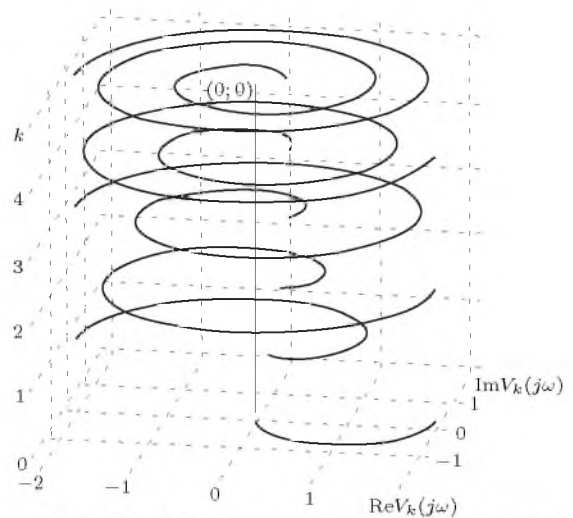
Частные случаи для преобразования Фурье фильтров 0-5 порядков:

$$V_0^{\{L_0^{(1)}(\tau, \gamma)\}}(j\omega) = \frac{\gamma^2}{(j\omega + \gamma/2)^2};$$

$$V_1^{\{L_1^{(1)}(\tau, \gamma)\}}(j\omega) = \frac{\gamma^2(j\omega - \gamma/2)}{(j\omega + \gamma/2)^3};$$

$$V_2^{\{L_2^{(1)}(\tau, \gamma)\}}(j\omega) = \frac{\gamma^2(j\omega - \gamma/2)^2}{(j\omega + \gamma/2)^4};$$

$$V_3^{\{L_3^{(1)}(\tau, \gamma)\}}(j\omega) = \frac{\gamma^2(j\omega - \gamma/2)^3}{(j\omega + \gamma/2)^5};$$

$$V_4^{\{L_4^{(1)}(\tau, \gamma)\}}(j\omega) = \frac{\gamma^2(j\omega - \gamma/2)^4}{(j\omega + \gamma/2)^6};$$

$$V_5^{\{L_5^{(1)}(\tau, \gamma)\}}(j\omega) = \frac{\gamma^2(j\omega - \gamma/2)^5}{(j\omega + \gamma/2)^7}.$$



Рис. 6.15. Вид преобразования Фурье ортогональных фильтров Сонина-Лагерра 0-5 порядков;  $\gamma = 4$ ,  $\alpha = 1$

$$[6.42] \quad V_k^{[1]\{L_k^{(2)}(\tau, \gamma)\}}(j\omega) = \\ = \frac{\gamma^3}{(j\omega + \gamma/2)^3} \sum_{s=0}^k \binom{k}{k-s} \left( \frac{-\gamma}{j\omega + \gamma/2} \right)^s.$$

$$[6.43] \quad V_k^{[2]\{L_k^{(2)}(\tau, \gamma)\}}(j\omega) = \frac{\gamma^3}{(j\omega + \gamma/2)^3} \left( \frac{j\omega - \gamma/2}{j\omega + \gamma/2} \right)^k.$$

$$[6.44] \quad V_k^{[3]\{L_k^{(2)}(\tau, \gamma)\}}(j\omega) = 8(-1)^k (\cos \varphi)^3 \times \\ \times \exp(-j(2k+3)\varphi), \quad \varphi = \arctan \frac{2\omega}{\gamma}.$$

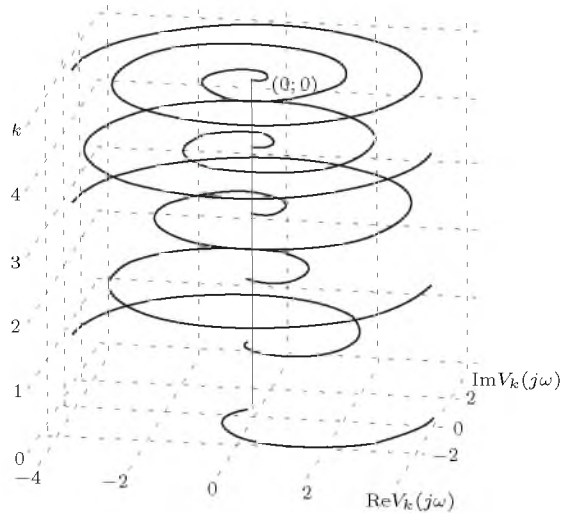
Частные случаи для преобразования Фурье фильтров 0-5 порядков:

$$V_0^{\{L_0^{(2)}(\tau, \gamma)\}}(j\omega) = \frac{\gamma^3}{(j\omega + \gamma/2)^3};$$

$$V_1^{\{L_1^{(2)}(\tau, \gamma)\}}(j\omega) = \frac{\gamma^3(j\omega - \gamma/2)}{(j\omega + \gamma/2)^4};$$

$$V_2^{\{L_2^{(2)}(\tau, \gamma)\}}(j\omega) = \frac{\gamma^3(j\omega - \gamma/2)^2}{(j\omega + \gamma/2)^5};$$

$$V_3^{\{L_3^{(2)}(\tau, \gamma)\}}(j\omega) = \frac{\gamma^3(j\omega - \gamma/2)^3}{(j\omega + \gamma/2)^6};$$

$$V_4^{\{L_4^{(2)}(\tau, \gamma)\}}(j\omega) = \frac{\gamma^3(j\omega - \gamma/2)^4}{(j\omega + \gamma/2)^7};$$

$$V_5^{\{L_5^{(2)}(\tau, \gamma)\}}(j\omega) = \frac{\gamma^3(j\omega - \gamma/2)^5}{(j\omega + \gamma/2)^8}.$$



Рис. 6.16. Вид преобразования Фурье ортогональных фильтров Сонина-Лагерра 0-5 порядков;  $\gamma = 4$ ,  $\alpha = 2$

$$[6.45] \quad V_k^{[1]\{L_k^{(\alpha)}(\tau, \gamma)\}}(j\omega) = \\ = \frac{\gamma^{\alpha+1}}{(j\omega + \gamma/2)^{\alpha+1}} \sum_{s=0}^k \binom{k}{k-s} \left( \frac{-\gamma}{j\omega + \gamma/2} \right)^s.$$

$$[6.46] \quad V_k^{[2]\{L_k^{(\alpha)}(\tau, \gamma)\}}(j\omega) = \\ = \left( \frac{\gamma}{j\omega + \gamma/2} \right)^{\alpha+1} \left( \frac{j\omega - \gamma/2}{j\omega + \gamma/2} \right)^k.$$

$$[6.47] \quad V_k^{[3]\{L_k^{(\alpha)}(\tau, \gamma)\}}(j\omega) = (-1)^k (2 \cos \varphi)^{\alpha+1} \times \\ \times \exp(-j(2k + \alpha + 1)\varphi), \quad \varphi = \arctan \frac{2\omega}{\gamma}.$$

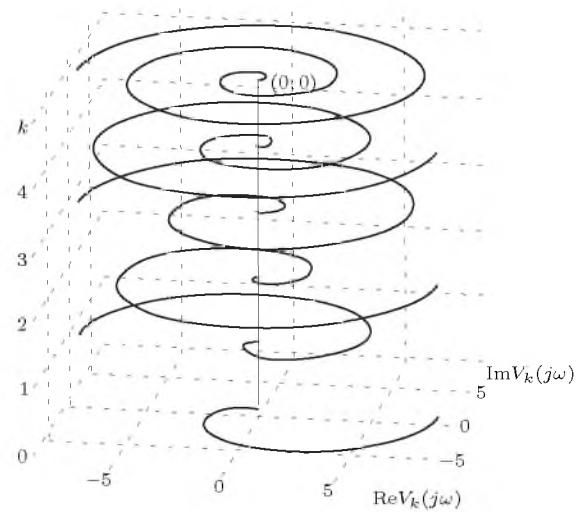
Частные случаи для преобразования Фурье фильтров 0-5 порядков:

$$V_0^{\{L_0^{(\alpha)}(\tau, \gamma)\}}(j\omega) = \frac{\gamma^{\alpha+1}}{(j\omega + \gamma/2)^{\alpha+1}};$$

$$V_1^{\{L_1^{(\alpha)}(\tau, \gamma)\}}(j\omega) = \frac{\gamma^{\alpha+1}(j\omega - \gamma/2)}{(j\omega + \gamma/2)^{\alpha+2}};$$

$$V_2^{\{L_2^{(\alpha)}(\tau, \gamma)\}}(j\omega) = \frac{\gamma^{\alpha+1}(j\omega - \gamma/2)^2}{(j\omega + \gamma/2)^{\alpha+3}};$$

$$V_3^{\{L_3^{(\alpha)}(\tau, \gamma)\}}(j\omega) = \frac{\gamma^{\alpha+1}(j\omega - \gamma/2)^3}{(j\omega + \gamma/2)^{\alpha+4}};$$

$$V_4^{\{L_4^{(\alpha)}(\tau, \gamma)\}}(j\omega) = \frac{\gamma^{\alpha+1}(j\omega - \gamma/2)^4}{(j\omega + \gamma/2)^{\alpha+5}};$$

$$V_5^{\{L_5^{(\alpha)}(\tau, \gamma)\}}(j\omega) = \frac{\gamma^{\alpha+1}(j\omega - \gamma/2)^5}{(j\omega + \gamma/2)^{\alpha+6}}.$$



Рис. 6.17. Вид преобразования Фурье ортогональных фильтров Сонина-Лагерра 2-го порядка: а)  $\gamma = 4, \alpha \in [0; 4]$ ; б)  $\gamma \in [1; 4], \alpha = 1$

[6.48]  $V_k^{\{P_k^{(-1/2,0)}(\tau, \gamma)\}}(j\omega) = (4k + 1)\gamma \times$

$$\times \sum_{s=0}^k \binom{k}{s} \binom{k+s-1/2}{s-1/2} (-1)^s \frac{1}{(4s+1)\gamma/2 + j\omega}.$$

[6.49]  $V_k^{\{P_k^{(-1/2,0)}(\tau, \gamma)\}}(j\omega) =$

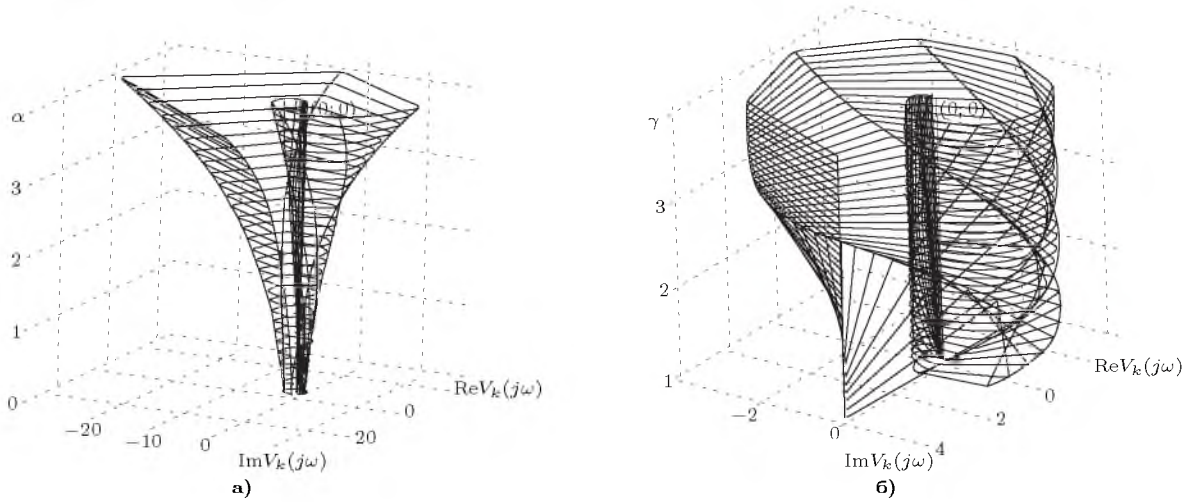
$$= \begin{cases} \frac{\gamma}{\gamma/2 + j\omega}, & \text{если } k = 0; \\ \frac{(4k+1)\gamma}{(4k+1)\gamma/2 + j\omega} \times \\ \times \prod_{s=0}^{k-1} \frac{(4s+1)\gamma/2 - j\omega}{(4s+1)\gamma/2 + j\omega}, & \text{если } k > 0. \end{cases}$$

[6.50]  $V_k^{\{P_k^{(-1/2,0)}(\tau, \gamma)\}}(j\omega) =$

$$= \begin{cases} 2 \cos \varphi_0 \exp(-j\varphi_0), & \text{если } k = 0; \\ 2 \cos \varphi_k \times \\ \times \exp\left(-j\left(\varphi_k + 2 \sum_{s=0}^{k-1} \varphi_s\right)\right), & \text{если } k > 0, \end{cases}$$

$$\varphi_k = \arctan \frac{2\omega}{(4k+1)\gamma}.$$

Частные случаи для преобразования Фурье фильтров 0-5 порядков:

$$V_0^{\{P_0^{(-1/2,0)}(\tau, \gamma)\}}(j\omega) = \frac{\gamma}{\gamma/2 + j\omega};$$

$$V_1^{\{P_1^{(-1/2,0)}(\tau, \gamma)\}}(j\omega) = \frac{5\gamma(\gamma/2 - j\omega)}{(\gamma/2 + j\omega)(5\gamma/2 + j\omega)};$$

$$V_2^{\{P_2^{(-1/2,0)}(\tau, \gamma)\}}(j\omega) = \frac{9\gamma(\gamma/2 - j\omega)(5\gamma/2 - j\omega)}{(\gamma/2 + j\omega)(5\gamma/2 + j\omega)(9\gamma/2 + j\omega)};$$

$$V_3^{\{P_3^{(-1/2,0)}(\tau, \gamma)\}}(j\omega) = \frac{13\gamma}{(13\gamma/2 + j\omega)} \frac{(\gamma/2 - j\omega)}{(\gamma/2 + j\omega)} \times$$

$$\times \frac{(5\gamma/2 - j\omega)(9\gamma/2 - j\omega)}{(5\gamma/2 + j\omega)(9\gamma/2 + j\omega)};$$

$$V_4^{\{P_4^{(-1/2,0)}(\tau, \gamma)\}}(j\omega) = \frac{17\gamma}{(17\gamma/2 + j\omega)} \frac{(\gamma/2 - j\omega)}{(\gamma/2 + j\omega)} \times$$

$$\times \frac{(5\gamma/2 - j\omega)(9\gamma/2 - j\omega)(13\gamma/2 - j\omega)}{(5\gamma/2 + j\omega)(9\gamma/2 + j\omega)(13\gamma/2 + j\omega)};$$

$$V_5^{\{P_5^{(-1/2,0)}(\tau, \gamma)\}}(j\omega) = \frac{21\gamma}{(21\gamma/2 + j\omega)} \frac{(\gamma/2 - j\omega)}{(\gamma/2 + j\omega)} \times$$

$$\times \frac{(5\gamma/2 - j\omega)(9\gamma/2 - j\omega)(13\gamma/2 - j\omega)(17\gamma/2 - j\omega)}{(5\gamma/2 + j\omega)(9\gamma/2 + j\omega)(13\gamma/2 + j\omega)(17\gamma/2 + j\omega)}.$$



Рис. 6.18. Вид преобразования Фурье ортогональных фильтров Якоби 0-5 порядков;  $\gamma = 1, c = 2, \alpha = -1/2, \beta = 0$



Рис. 6.19. Вид преобразования Фурье ортогональных фильтров Лежандра 0-5 порядков;  $\gamma = 1, c = 2$

$$[6.51] \quad V_k^{[1]\{Leg_k(\tau, \gamma)\}}(j\omega) = 2(2k+1)\gamma \times \sum_{s=0}^k \binom{k}{s} \binom{k+s}{s} (-1)^s \frac{1}{(2s+1)\gamma + j\omega}.$$

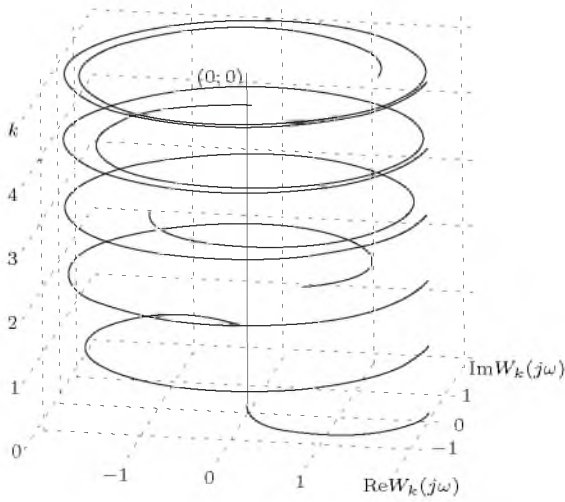
$$[6.52] \quad V_k^{[2]\{Leg_k(\tau, \gamma)\}}(j\omega) = \begin{cases} \frac{2\gamma}{\gamma + j\omega}, & \text{если } k = 0; \\ \frac{2(2k+1)\gamma}{(2k+1)\gamma + j\omega} \prod_{s=0}^{k-1} \frac{(2s+1)\gamma - j\omega}{(2s+1)\gamma + j\omega}, & \text{если } k > 0. \end{cases}$$

$$[6.53] \quad V_k^{[3]\{Leg_k(\tau, \gamma)\}}(j\omega) = \begin{cases} 2 \cos \varphi_0 \exp(-j\varphi_0), & \text{если } k = 0; \\ 2 \cos \varphi_k \times \exp\left(-j\left(\varphi_k + 2 \sum_{s=0}^{k-1} \varphi_s\right)\right), & \text{если } k > 0, \end{cases}$$

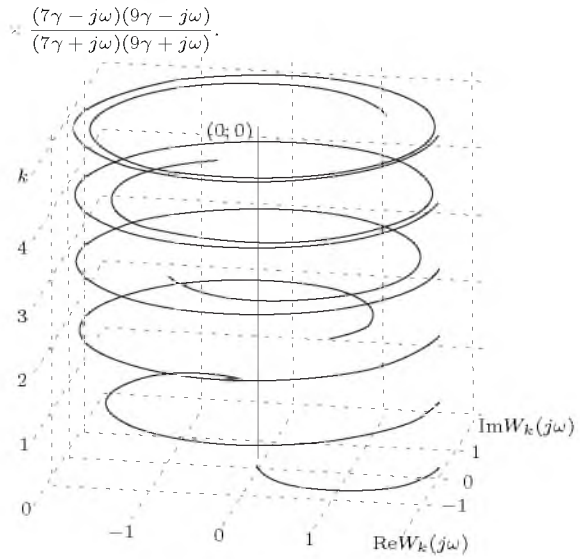
$$\varphi_k = \arctan \frac{\omega}{(2k+1)\gamma}.$$

Частные случаи для преобразования Фурье фильтров 0-5 порядков:

$$V_0^{\{Leg_0(\tau, \gamma)\}}(j\omega) = \frac{2\gamma}{\gamma + j\omega};$$

$$V_1^{\{Leg_1(\tau, \gamma)\}}(j\omega) = \frac{6\gamma(\gamma - j\omega)}{(\gamma + j\omega)(3\gamma + j\omega)};$$

$$V_2^{\{Leg_2(\tau, \gamma)\}}(j\omega) = \frac{10\gamma(\gamma - j\omega)(3\gamma - j\omega)}{(\gamma + j\omega)(3\gamma + j\omega)(5\gamma + j\omega)};$$

$$V_3^{\{Leg_3(\tau, \gamma)\}}(j\omega) = \frac{14\gamma(\gamma - j\omega)(3\gamma - j\omega)(5\gamma - j\omega)}{(\gamma + j\omega)(3\gamma + j\omega)(5\gamma + j\omega)(7\gamma + j\omega)};$$

$$V_4^{\{Leg_4(\tau, \gamma)\}}(j\omega) = \frac{18\gamma(\gamma - j\omega)(3\gamma - j\omega)(5\gamma - j\omega)}{(9\gamma + j\omega)(\gamma + j\omega)(3\gamma + j\omega)(5\gamma + j\omega)} \times \frac{(\gamma - j\omega)}{(\gamma + j\omega)};$$

$$V_5^{\{Leg_5(\tau, \gamma)\}}(j\omega) = \frac{22\gamma(\gamma - j\omega)(3\gamma - j\omega)(5\gamma - j\omega)}{(11\gamma + j\omega)(\gamma + j\omega)(3\gamma + j\omega)(5\gamma + j\omega)} \times$$

$$\times \frac{(\gamma - j\omega)(9\gamma - j\omega)}{(\gamma + j\omega)(9\gamma + j\omega)}.$$

$$[6.54] \quad V_k^{[1]\{P_k^{(1/2,0)}(\tau, \gamma)\}}(j\omega) = (4k+3)\gamma \times \sum_{s=0}^k \binom{k}{s} \binom{k+s+1/2}{s+1/2} (-1)^s \frac{1}{(4s+3)\gamma/2 + j\omega}.$$

$$[6.55] \quad V_k^{[2]\{P_k^{(1/2,0)}(\tau, \gamma)\}}(j\omega) = \begin{cases} \frac{3\gamma}{3\gamma/2 + j\omega}, & \text{если } k = 0; \\ \frac{(4k+3)\gamma}{(4k+3)\gamma/2 + j\omega} \times \prod_{s=0}^{k-1} \frac{(4s+3)\gamma/2 - j\omega}{(4s+3)\gamma/2 + j\omega}, & \text{если } k > 0. \end{cases}$$

$$[6.56] \quad V_k^{[3]\{P_k^{(1/2,0)}(\tau, \gamma)\}}(j\omega) = \begin{cases} 2 \cos \varphi_0 \exp(-j\varphi_0), & \text{если } k = 0; \\ 2 \cos \varphi_k \times \exp\left(-j\left(\varphi_k + 2 \sum_{s=0}^{k-1} \varphi_s\right)\right), & \text{если } k > 0, \end{cases}$$

$$\varphi_k = \arctan \frac{2\omega}{(4k+3)\gamma}.$$

Частные случаи для преобразования Фурье фильтров 0-5 порядков:

$$V_0^{\{P_0^{(1/2,0)}(\tau, \gamma)\}}(j\omega) = \frac{3\gamma}{3\gamma/2 + j\omega};$$

$$V_1^{\{P_1^{(1/2,0)}(\tau, \gamma)\}}(j\omega) = \frac{7\gamma(3\gamma/2 - j\omega)}{(3\gamma/2 + j\omega)(7\gamma/2 + j\omega)};$$

$$V_2^{\{P_2^{(1/2,0)}(\tau, \gamma)\}}(j\omega) = \frac{11\gamma(3\gamma/2 - j\omega)(7\gamma/2 - j\omega)}{(3\gamma/2 + j\omega)(7\gamma/2 + j\omega)(11\gamma/2 + j\omega)};$$

$$V_3^{\{P_3^{(1/2,0)}(\tau, \gamma)\}}(j\omega) = \frac{15\gamma(3\gamma/2 - j\omega)}{(15\gamma/2 + j\omega)(3\gamma/2 + j\omega)} \times$$



$$\begin{aligned} & \times \frac{(7\gamma/2 - j\omega)(11\gamma/2 - j\omega)}{(7\gamma/2 + j\omega)(11\gamma/2 + j\omega)}; \\ V_4^{\{P_4^{(1/2,0)}(\tau,\gamma)\}}(j\omega) &= \frac{19\gamma}{(19\gamma/2 + j\omega)} \frac{(3\gamma/2 - j\omega)}{(3\gamma/2 + j\omega)} \times \\ & \times \frac{(7\gamma/2 - j\omega)(11\gamma/2 - j\omega)(15\gamma/2 - j\omega)}{(7\gamma/2 + j\omega)(11\gamma/2 + j\omega)(15\gamma/2 + j\omega)}; \\ V_5^{\{P_5^{(1/2,0)}(\tau,\gamma)\}}(j\omega) &= \frac{23\gamma}{(23\gamma/2 + j\omega)} \frac{(3\gamma/2 - j\omega)}{(3\gamma/2 + j\omega)} \times \\ & \times \frac{(7\gamma/2 - j\omega)(11\gamma/2 - j\omega)(15\gamma/2 - j\omega)(19\gamma/2 - j\omega)}{(7\gamma/2 + j\omega)(11\gamma/2 + j\omega)(15\gamma/2 + j\omega)(19\gamma/2 + j\omega)}. \end{aligned}$$



Рис. 6.20. Вид преобразования Фурье ортогональных фильтров Якоби 0-5 порядков;  $\gamma = 1, c = 2, \alpha = 1/2, \beta = 0$

[6.57]  $V_k^{\{P_k^{(1,0)}(\tau,\gamma)\}}(j\omega) = 2(k+1)\gamma \times$   
 $\times \sum_{s=0}^k \binom{k}{s} \binom{k+s+1}{s+1} (-1)^s \frac{1}{(s+1)\gamma + j\omega}.$

[6.58]  $V_k^{\{P_k^{(2,0)}(\tau,\gamma)\}}(j\omega) =$   
 $= \begin{cases} \frac{2\gamma}{\gamma + j\omega}, & \text{если } k = 0; \\ \frac{2(k+1)\gamma}{(k+1)\gamma + j\omega} \prod_{s=0}^{k-1} \frac{(s+1)\gamma - j\omega}{(s+1)\gamma + j\omega}, & \text{если } k > 0. \end{cases}$

[6.59]  $V_k^{\{P_k^{(3,0)}(\tau,\gamma)\}}(j\omega) =$   
 $= \begin{cases} 2 \cos \varphi_0 \exp(-j\varphi_0), & \text{если } k = 0; \\ 2 \cos \varphi_k \times \\ \times \exp\left(-j\left(\varphi_k + 2 \sum_{s=0}^{k-1} \varphi_s\right)\right), & \text{если } k > 0, \end{cases}$   
 $\varphi_k = \arctan \frac{\omega}{(k+1)\gamma}.$

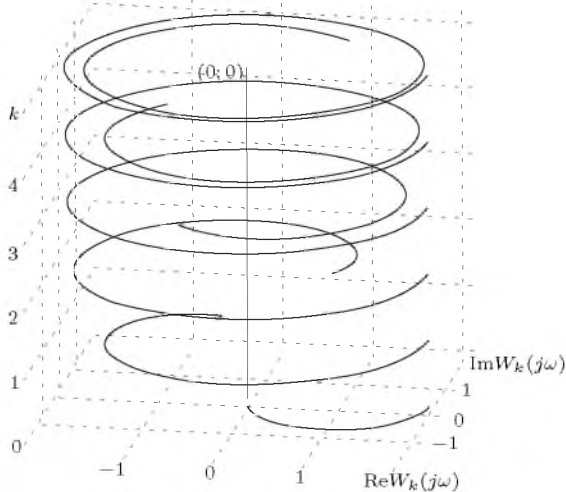
Частные случаи для преобразования Фурье фильтров 0-5 порядков:

$V_0^{\{P_0^{(1,0)}(\tau,\gamma)\}}(j\omega) = \frac{2\gamma}{\gamma + j\omega};$

$$\begin{aligned} V_1^{\{P_1^{(1,0)}(\tau,\gamma)\}}(j\omega) &= \frac{4\gamma(\gamma - j\omega)}{(\gamma + j\omega)(2\gamma + j\omega)}; \\ V_2^{\{P_2^{(1,0)}(\tau,\gamma)\}}(j\omega) &= \frac{6\gamma(\gamma - j\omega)(2\gamma - j\omega)}{(\gamma + j\omega)(2\gamma + j\omega)(3\gamma + j\omega)}; \\ V_3^{\{P_3^{(1,0)}(\tau,\gamma)\}}(j\omega) &= \frac{8\gamma(\gamma - j\omega)(2\gamma - j\omega)(3\gamma - j\omega)}{(\gamma + j\omega)(2\gamma + j\omega)(3\gamma + j\omega)(4\gamma + j\omega)}; \\ V_4^{\{P_4^{(1,0)}(\tau,\gamma)\}}(j\omega) &= \frac{10\gamma}{(5\gamma + j\omega)} \frac{(\gamma - j\omega)(2\gamma - j\omega)(3\gamma - j\omega)}{(\gamma + j\omega)(2\gamma + j\omega)(3\gamma + j\omega)} \times \\ & \times \frac{(4\gamma - j\omega)}{(4\gamma + j\omega)}; \\ V_5^{\{P_5^{(1,0)}(\tau,\gamma)\}}(j\omega) &= \frac{12\gamma}{(6\gamma + j\omega)} \frac{(\gamma - j\omega)(2\gamma - j\omega)(3\gamma - j\omega)}{(\gamma + j\omega)(2\gamma + j\omega)(3\gamma + j\omega)} \times \\ & \times \frac{(4\gamma - j\omega)(5\gamma - j\omega)}{(4\gamma + j\omega)(5\gamma + j\omega)}. \end{aligned}$$



Рис. 6.21. Вид преобразования Фурье ортогональных фильтров Якоби 0-5 порядков;  $\gamma = 1, c = 1, \alpha = 1, \beta = 0$

[6.60]  $V_k^{\{P_k^{(2,0)}(\tau,\gamma)\}}(j\omega) = 2(2k+3)\gamma \times$   
 $\times \sum_{s=0}^k \binom{k}{s} \binom{k+s+2}{s+2} (-1)^s \frac{1}{(2s+3)\gamma + j\omega}.$

[6.61]  $V_k^{\{P_k^{(2,0)}(\tau,\gamma)\}}(j\omega) =$   
 $= \begin{cases} \frac{6\gamma}{3\gamma + j\omega}, & \text{если } k = 0; \\ \frac{2(2k+3)\gamma}{(2k+3)\gamma + j\omega} \prod_{s=0}^{k-1} \frac{(2s+3)\gamma - j\omega}{(2s+3)\gamma + j\omega}, & \text{если } k > 0. \end{cases}$

[6.62]  $V_k^{\{P_k^{(3,0)}(\tau,\gamma)\}}(j\omega) =$   
 $= \begin{cases} 2 \cos \varphi_0 \exp(-j\varphi_0), & \text{если } k = 0; \\ 2 \cos \varphi_k \times \\ \times \exp\left(-j\left(\varphi_k + 2 \sum_{s=0}^{k-1} \varphi_s\right)\right), & \text{если } k > 0, \end{cases}$   
 $\varphi_k = \arctan \frac{\omega}{(2k+3)\gamma}.$

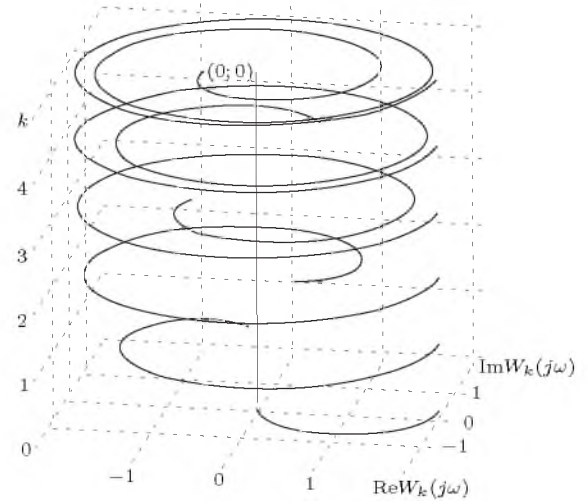
Частные случаи для преобразования Фурье фильтров 0-5 порядков:

$$\begin{aligned}
 V_0^{\{P_0^{(2,0)}(\tau,\gamma)\}}(j\omega) &= \frac{6\gamma}{3\gamma + j\omega}; \\
 V_1^{\{P_1^{(2,0)}(\tau,\gamma)\}}(j\omega) &= \frac{10\gamma(3\gamma - j\omega)}{(3\gamma + j\omega)(5\gamma + j\omega)}; \\
 V_2^{\{P_2^{(2,0)}(\tau,\gamma)\}}(j\omega) &= \frac{14\gamma(3\gamma - j\omega)(5\gamma - j\omega)}{(3\gamma + j\omega)(5\gamma + j\omega)(7\gamma + j\omega)}; \\
 V_3^{\{P_3^{(2,0)}(\tau,\gamma)\}}(j\omega) &= \frac{18\gamma}{(9\gamma + j\omega)} \frac{(3\gamma - j\omega)(5\gamma - j\omega)}{(3\gamma + j\omega)(5\gamma + j\omega)} \times \\
 &\times \frac{(7\gamma - j\omega)}{(7\gamma + j\omega)}; \\
 V_4^{\{P_4^{(2,0)}(\tau,\gamma)\}}(j\omega) &= \frac{22\gamma}{(11\gamma + j\omega)} \frac{(3\gamma - j\omega)(5\gamma - j\omega)}{(3\gamma + j\omega)(5\gamma + j\omega)} \times \\
 &\times \frac{(7\gamma - j\omega)(9\gamma - j\omega)}{(7\gamma + j\omega)(9\gamma + j\omega)}; \\
 V_5^{\{P_5^{(2,0)}(\tau,\gamma)\}}(j\omega) &= \frac{26\gamma}{(13\gamma + j\omega)} \frac{(3\gamma - j\omega)(5\gamma - j\omega)}{(3\gamma + j\omega)(5\gamma + j\omega)} \times \\
 &\times \frac{(7\gamma - j\omega)(9\gamma - j\omega)(11\gamma - j\omega)}{(7\gamma + j\omega)(9\gamma + j\omega)(11\gamma + j\omega)}.
 \end{aligned}$$



Рис. 6.22. Вид преобразования Фурье ортогональных фильтров Якоби 0-5 порядков;  $\gamma = 1, c = 2, \alpha = 2, \beta = 0$

$$\begin{aligned}
 [6.63] \quad V_k^{\{P_k^{(\alpha,0)}(\tau,\gamma)\}}(j\omega) &= (2k + \alpha + 1)c\gamma \times \\
 &\times \sum_{s=0}^k \binom{k}{s} \binom{k+s+\alpha}{s+\alpha} (-1)^s \frac{1}{(2s + \alpha + 1)c\gamma/2 + j\omega}.
 \end{aligned}$$

$$\begin{aligned}
 [6.64] \quad V_k^{\{P_k^{(\alpha,0)}(\tau,\gamma)\}}(j\omega) &= \\
 &= \begin{cases} \frac{(\alpha + 1)c\gamma}{(\alpha + 1)c\gamma/2 + j\omega}, & \text{если } k = 0; \\ \frac{(\alpha + 1)c\gamma/2 + j\omega}{(2k + \alpha + 1)c\gamma} \times \\ \times \prod_{s=0}^{k-1} \frac{(2s + \alpha + 1)c\gamma/2 - j\omega}{(2s + \alpha + 1)c\gamma/2 + j\omega}, & \text{если } k > 0. \end{cases}
 \end{aligned}$$

$$\begin{aligned}
 [6.65] \quad V_k^{\{P_k^{(\alpha,0)}(\tau,\gamma)\}}(j\omega) &= \\
 &= \begin{cases} 2 \cos \varphi_0 \exp(-j\varphi_0), & \text{если } k = 0; \\ 2 \cos \varphi_k \times \\ \times \exp\left(-j\left(\varphi_k + 2 \sum_{s=0}^{k-1} \varphi_s\right)\right), & \text{если } k > 0, \end{cases} \\
 \varphi_k &= \arctan \frac{2\omega}{(2k + \alpha + 1)c\gamma}.
 \end{aligned}$$

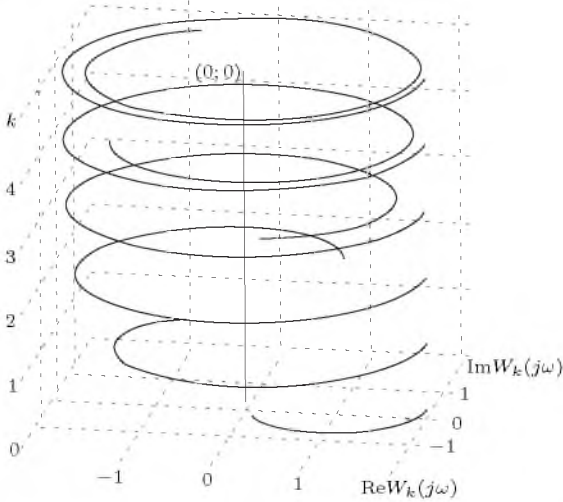
Частные случаи для преобразования Фурье фильтров 0-5 порядков:

$$\begin{aligned}
 V_0^{\{P_0^{(\alpha,0)}(\tau,\gamma)\}}(j\omega) &= \frac{(\alpha + 1)c\gamma}{(\alpha + 1)c\gamma/2 + j\omega}; \\
 V_1^{\{P_1^{(\alpha,0)}(\tau,\gamma)\}}(j\omega) &= \frac{(\alpha + 3)c\gamma((\alpha + 1)c\gamma/2 - j\omega)}{((\alpha + 1)c\gamma/2 + j\omega)((\alpha + 3)c\gamma/2 + j\omega)}; \\
 V_2^{\{P_2^{(\alpha,0)}(\tau,\gamma)\}}(j\omega) &= \frac{(\alpha + 5)c\gamma}{((\alpha + 5)c\gamma/2 + j\omega)} \frac{((\alpha + 1)c\gamma/2 - j\omega)}{((\alpha + 1)c\gamma/2 + j\omega)} \times \\
 &\times \frac{((\alpha + 3)c\gamma/2 - j\omega)}{((\alpha + 3)c\gamma/2 + j\omega)}; \\
 V_3^{\{P_3^{(\alpha,0)}(\tau,\gamma)\}}(j\omega) &= \frac{(\alpha + 7)c\gamma}{((\alpha + 7)c\gamma/2 + j\omega)} \frac{((\alpha + 1)c\gamma/2 - j\omega)}{((\alpha + 1)c\gamma/2 + j\omega)} \times \\
 &\times \frac{((\alpha + 3)c\gamma/2 - j\omega)((\alpha + 5)c\gamma/2 - j\omega)}{((\alpha + 3)c\gamma/2 + j\omega)((\alpha + 5)c\gamma/2 + j\omega)}; \\
 V_4^{\{P_4^{(\alpha,0)}(\tau,\gamma)\}}(j\omega) &= \frac{(\alpha + 9)c\gamma}{((\alpha + 9)c\gamma/2 + j\omega)} \frac{((\alpha + 1)c\gamma/2 - j\omega)}{((\alpha + 7)c\gamma/2 + j\omega)} \times \\
 &\times \frac{((\alpha + 3)c\gamma/2 - j\omega)((\alpha + 5)c\gamma/2 - j\omega)((\alpha + 7)c\gamma/2 - j\omega)}{((\alpha + 3)c\gamma/2 + j\omega)((\alpha + 5)c\gamma/2 + j\omega)((\alpha + 7)c\gamma/2 + j\omega)}; \\
 V_5^{\{P_5^{(\alpha,0)}(\tau,\gamma)\}}(j\omega) &= \frac{(\alpha + 11)c\gamma}{((\alpha + 11)c\gamma/2 + j\omega)} \times \\
 &\times \frac{((\alpha + 1)c\gamma/2 - j\omega)((\alpha + 3)c\gamma/2 - j\omega)((\alpha + 5)c\gamma/2 - j\omega)}{((\alpha + 3)c\gamma/2 + j\omega)((\alpha + 3)c\gamma/2 + j\omega)((\alpha + 5)c\gamma/2 + j\omega)} \times \\
 &\times \frac{((\alpha + 7)c\gamma/2 - j\omega)((\alpha + 9)c\gamma/2 - j\omega)}{((\alpha + 7)c\gamma/2 + j\omega)((\alpha + 9)c\gamma/2 + j\omega)}.
 \end{aligned}$$



Рис. 6.23. Вид преобразования Фурье ортогональных фильтров Якоби 2-ого порядка: а)  $\gamma = 1, c = 2, \alpha \in [0; 4], \beta = 0$ ; б)  $\gamma \in [1; 3, 5], c = 2, \alpha = 1, \beta = 0$

$$[6.66] \quad V_k^{[1]\{P_k^{(0,1)}(\tau, \gamma)\}}(j\omega) = \frac{8\gamma^2(k+1)^2}{(2k+3)\gamma + j\omega} \times \sum_{s=0}^k \binom{k}{s} \binom{k+s}{s} (-1)^s \frac{1}{(2s+1)\gamma + j\omega}.$$

$$[6.67] \quad V_k^{[2]\{P_k^{(0,1)}(\tau, \gamma)\}}(j\omega) = \begin{cases} \frac{8\gamma^2}{(\gamma + j\omega)(3\gamma + j\omega)}, & \text{если } k = 0; \\ \frac{8(k+1)^2\gamma^2}{((2k+1)\gamma + j\omega)((2k+3)\gamma + j\omega)} \times \prod_{s=0}^{k-1} \frac{(2s+1)\gamma - j\omega}{(2s+1)\gamma + j\omega}, & \text{если } k > 0. \end{cases}$$

$$[6.68] \quad V_k^{[3]\{P_k^{(0,1)}(\tau, \gamma)\}}(j\omega) = \begin{cases} \frac{8(k+1)^2 \cos \varphi_0^{[0]} \cos \varphi_0^{[1]}}{3} \times \exp(-j(\varphi_0^{[0]} + \varphi_0^{[1]})), & \text{если } k = 0; \\ \frac{8(k+1)^2 \cos \varphi_k^{[0]} \cos \varphi_k^{[1]}}{(2k+1)(2k+3)} \times \exp\left(-j\left(\varphi_k^{[0]} + \varphi_k^{[1]} + 2 \sum_{s=0}^{k-1} \varphi_s^{[0]}\right)\right), & \text{если } k > 0, \end{cases}$$

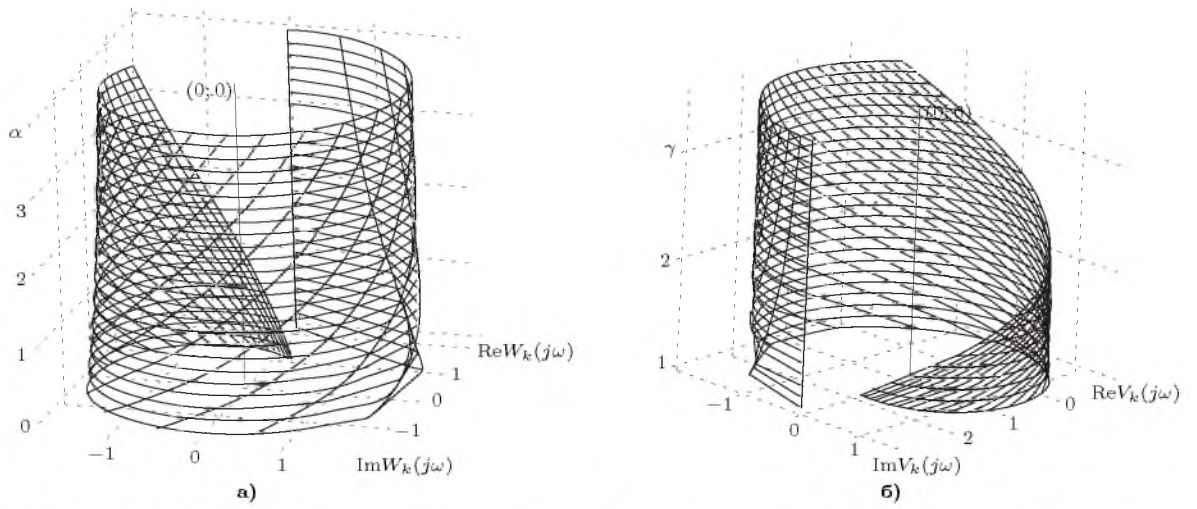
$$\varphi_k^{[0]} = \arctan \frac{\omega}{(2k+1)\gamma}; \quad \varphi_k^{[1]} = \arctan \frac{\omega}{(2k+3)\gamma}.$$

Частные случаи для преобразования Фурье фильтров 0-5 порядков:

$$V_0^{(P_0^{(0,1)})}(\tau, \gamma)(j\omega) = \frac{8\gamma^2}{(\gamma + j\omega)(3\gamma + j\omega)};$$

$$V_1^{(P_1^{(0,1)})}(\tau, \gamma)(j\omega) = \frac{32\gamma^2}{(3\gamma + j\omega)(5\gamma + j\omega)} \frac{(\gamma - j\omega)}{(\gamma + j\omega)};$$

$$V_2^{(P_2^{(0,1)})}(\tau, \gamma)(j\omega) = \frac{72\gamma^2}{(5\gamma + j\omega)(7\gamma + j\omega)} \frac{(\gamma - j\omega)(3\gamma - j\omega)}{(\gamma + j\omega)(3\gamma + j\omega)};$$

$$V_3^{(P_3^{(0,1)})}(\tau, \gamma)(j\omega) = \frac{128\gamma^2}{(7\gamma + j\omega)(9\gamma + j\omega)} \frac{(\gamma - j\omega)}{(\gamma + j\omega)} \times \frac{(3\gamma - j\omega)(5\gamma - j\omega)}{(3\gamma + j\omega)(5\gamma + j\omega)};$$

$$V_4^{(P_4^{(0,1)})}(\tau, \gamma)(j\omega) = \frac{200\gamma^2}{(9\gamma + j\omega)(11\gamma + j\omega)} \frac{(\gamma - j\omega)}{(\gamma + j\omega)} \times \frac{(3\gamma - j\omega)(5\gamma - j\omega)(7\gamma - j\omega)}{(3\gamma + j\omega)(5\gamma + j\omega)(7\gamma + j\omega)};$$

$$V_5^{(P_5^{(0,1)})}(\tau, \gamma)(j\omega) = \frac{288\gamma^2}{(11\gamma + j\omega)(13\gamma + j\omega)} \frac{(\gamma - j\omega)}{(\gamma + j\omega)} \times \frac{(3\gamma - j\omega)(5\gamma - j\omega)(7\gamma - j\omega)(9\gamma - j\omega)}{(3\gamma + j\omega)(5\gamma + j\omega)(7\gamma + j\omega)(9\gamma + j\omega)}.$$



Рис. 6.24. Вид преобразования Фурье ортогональных фильтров Якоби 0-5 порядков;  $\gamma = 1, c = 2, \alpha = 0, \beta = 1$

$$\begin{aligned}
 [6.69] \quad V_k^{[1]\{P_k^{(0,2)}(\tau, \gamma)\}}(j\omega) &= \\
 &= \frac{8(2k+3)(k+1)(k+2)\gamma^3}{((2k+3)\gamma + j\omega)((2k+5)\gamma + j\omega)} \times \\
 &\quad \times \sum_{s=0}^k \binom{k}{s} \binom{k+s}{s} (-1)^s \frac{1}{(2s+1)\gamma + j\omega}.
 \end{aligned}$$

$$\begin{aligned}
 [6.70] \quad V_k^{[2]\{P_k^{(0,2)}(\tau, \gamma)\}}(j\omega) &= \\
 &= \begin{cases} \frac{48\gamma^3}{(\gamma + j\omega)(3\gamma + j\omega)(5\gamma + j\omega)}, & \text{если } k = 0; \\ \frac{((2k+1)\gamma + j\omega)((2k+3)\gamma + j\omega)}{(k+1)(k+2)} \times \\ \times \frac{((2k+5)\gamma + j\omega)}{(2s+1)\gamma - j\omega} \times \prod_{s=0}^{k-1} \frac{(2s+1)\gamma - j\omega}{(2s+1)\gamma + j\omega}, & \text{если } k > 0. \end{cases}
 \end{aligned}$$

$$\begin{aligned}
 [6.71] \quad V_k^{[3]\{P_k^{(0,2)}(\tau, \gamma)\}}(j\omega) &= \\
 &= \begin{cases} \frac{16 \cos \varphi_0^{[0]} \cos \varphi_0^{[1]} \cos \varphi_0^{[2]} / 5 \times \\ \times \exp(-j(\varphi_0^{[0]} + \varphi_0^{[1]} + \varphi_0^{[2]}))}{8(k+1)(k+2) \cos \varphi_k^{[0]} \cos \varphi_k^{[1]}}, & \text{если } k = 0; \\ \frac{(2k+1)(2k+5)}{\times \cos \varphi_k^{[2]} \exp(-j(\varphi_k^{[0]} + \varphi_k^{[1]} + \\ + \varphi_k^{[2]} + 2 \sum_{s=0}^{k-1} \varphi_s^{[0]}))}, & \text{если } k > 0, \end{cases} \\
 \varphi_k^{[0]} = \arctan \frac{\omega}{(2k+1)\gamma}; \quad \varphi_k^{[1]} = \arctan \frac{\omega}{(2k+3)\gamma}; \\
 \varphi_k^{[2]} = \arctan \frac{\omega}{(2k+5)\gamma}.
 \end{aligned}$$

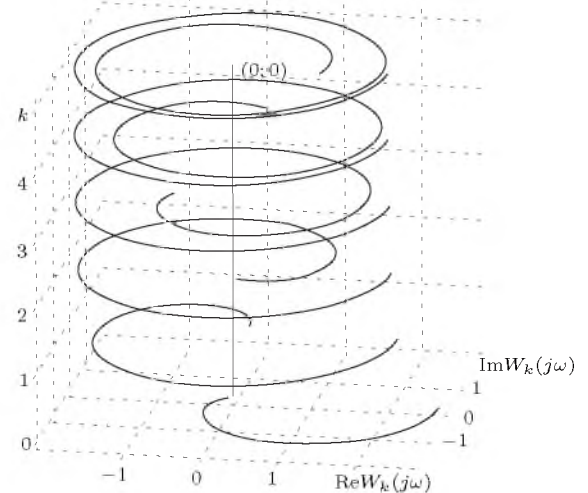
Частные случаи для преобразования Фурье фильтров 0-5 порядков:

$$\begin{aligned}
 V_0^{[1]\{P_0^{(0,2)}(\tau, \gamma)\}}(j\omega) &= \frac{48\gamma^3}{(\gamma + j\omega)(3\gamma + j\omega)(5\gamma + j\omega)}; \\
 V_1^{[1]\{P_1^{(0,2)}(\tau, \gamma)\}}(j\omega) &= \frac{240\gamma^3}{(3\gamma + j\omega)(5\gamma + j\omega)(7\gamma + j\omega)} \frac{(\gamma - j\omega)}{(\gamma + j\omega)}; \\
 V_2^{[1]\{P_2^{(0,2)}(\tau, \gamma)\}}(j\omega) &= \frac{672\gamma^3}{(5\gamma + j\omega)(7\gamma + j\omega)(9\gamma + j\omega)} \frac{(\gamma - j\omega)}{(\gamma + j\omega)} \times \\
 &\quad \times \frac{(3\gamma - j\omega)}{(3\gamma + j\omega)}; \\
 V_3^{[1]\{P_3^{(0,2)}(\tau, \gamma)\}}(j\omega) &= \frac{1440\gamma^3}{(7\gamma + j\omega)(9\gamma + j\omega)(11\gamma + j\omega)} \times \\
 &\quad \times \frac{(\gamma - j\omega)(3\gamma - j\omega)(5\gamma - j\omega)}{(\gamma + j\omega)(3\gamma + j\omega)(5\gamma + j\omega)}; \\
 V_4^{[1]\{P_4^{(0,2)}(\tau, \gamma)\}}(j\omega) &= \frac{2640\gamma^3}{(9\gamma + j\omega)(11\gamma + j\omega)(13\gamma + j\omega)} \times \\
 &\quad \times \frac{(\gamma - j\omega)(3\gamma - j\omega)(5\gamma - j\omega)(7\gamma - j\omega)}{(\gamma + j\omega)(3\gamma + j\omega)(5\gamma + j\omega)(7\gamma + j\omega)}; \\
 V_5^{[1]\{P_5^{(0,2)}(\tau, \gamma)\}}(j\omega) &= \frac{4368\gamma^3}{(11\gamma + j\omega)(13\gamma + j\omega)(15\gamma + j\omega)} \times \\
 &\quad \times \frac{(\gamma - j\omega)(3\gamma - j\omega)(5\gamma - j\omega)(7\gamma - j\omega)(9\gamma - j\omega)}{(\gamma + j\omega)(3\gamma + j\omega)(5\gamma + j\omega)(7\gamma + j\omega)(9\gamma + j\omega)}.
 \end{aligned}$$



Рис. 6.25. Вид преобразования Фурье ортогональных фильтров Якоби 0-5 порядков;  $\gamma = 1$ ,  $c = 2$ ,  $\alpha = 0$ ,  $\beta = 2$

$$\begin{aligned}
 [6.72] \quad V_k^{[1]\{P_k^{(0,\beta)}(\tau, \gamma)\}}(j\omega) &= \\
 &= \frac{(c\gamma)^{\beta+1}(2k+\beta+1)(k+\beta)!}{k! \prod_{p=1}^{\beta} ((2k+2p+1)c\gamma/2 + j\omega)} \times \\
 &\quad \times \sum_{s=0}^k \binom{k}{s} \binom{k+s}{s} (-1)^s \frac{1}{(2s+1)c\gamma/2 + j\omega}.
 \end{aligned}$$

$$\begin{aligned}
 [6.73] \quad V_k^{[2]\{P_k^{(0,\beta)}(\tau, \gamma)\}}(j\omega) &= \\
 &= \begin{cases} \frac{(c\gamma)^{\beta+1}(\beta+1)!}{\prod_{p=0}^{\beta} ((2p+1)c\gamma/2 + j\omega)}, & \text{если } k = 0; \\ \frac{(c\gamma)^{\beta+1}(2k+\beta+1)(k+\beta)!}{k! \prod_{p=0}^{\beta} ((2k+2p+1)c\gamma/2 + j\omega)} \times \\ \times \prod_{s=0}^{k-1} \frac{(2s+1)c\gamma/2 - j\omega}{(2s+1)c\gamma/2 + j\omega}, & \text{если } k > 0. \end{cases}
 \end{aligned}$$

$$\begin{aligned}
 [6.74] \quad V_k^{[3]\{P_k^{(0,\beta)}(\tau, \gamma)\}}(j\omega) &= \\
 &= \begin{cases} \frac{2^{\beta+1}(\beta+1)! \prod_{p=0}^{\beta} \frac{\cos \varphi_0^{[p]}}{2p+1}}{\times \exp(-j \sum_{p=0}^{\beta} \varphi_0^{[p]})}, & \text{если } k = 0; \\ \frac{2^{\beta+1}(2k+\beta+1)(k+\beta)!/k! \times \\ \times \prod_{p=0}^{\beta} \frac{\cos \varphi_k^{[p]}}{2k+2p+1} \times \\ \times \exp(-j(\sum_{p=0}^{\beta} \varphi_k^{[p]} + 2 \sum_{s=0}^{k-1} \varphi_s^{[0]}))}{\varphi_k^{[p]} = \arctan \frac{2\omega}{(2k+2p+1)c\gamma}; \quad \beta \in \mathbb{Z}.} & \text{если } k > 0, \end{cases}
 \end{aligned}$$

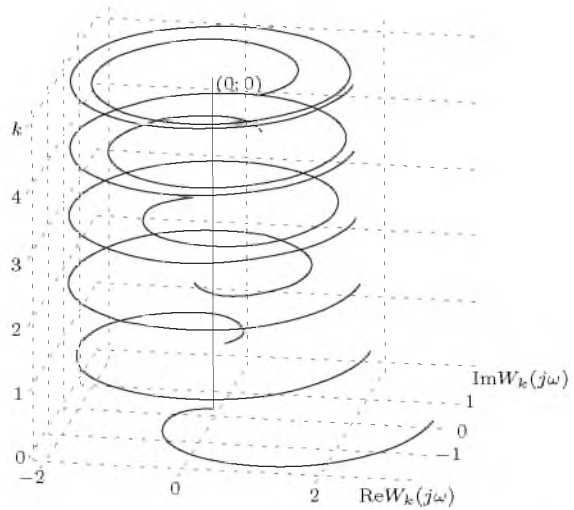
Частные случаи для преобразования Фурье фильтров 0-5 порядков:

$$V_0^{\{P_0^{(0,\beta)}(\tau,\gamma)\}}(j\omega) = \frac{(c\gamma)^{\beta+1}(\beta+1)!}{\prod_{p=0}^{\beta} ((2p+1)c\gamma/2 + j\omega)};$$

$$V_1^{\{P_1^{(0,\beta)}(\tau,\gamma)\}}(j\omega) = \frac{(c\gamma)^{\beta+1}(\beta+3)(\beta+1)!}{\prod_{p=0}^{\beta} ((2p+3)c\gamma/2 + j\omega)} \frac{(c\gamma/2 - j\omega)}{(c\gamma/2 + j\omega)};$$

$$V_2^{\{P_2^{(0,\beta)}(\tau,\gamma)\}}(j\omega) = \frac{(c\gamma)^{\beta+1}(\beta+5)(\beta+2)!}{2 \prod_{p=0}^{\beta} ((2p+5)c\gamma/2 + j\omega)} \frac{(c\gamma/2 - j\omega)}{(c\gamma/2 + j\omega)} \times \frac{(3c\gamma/2 - j\omega)}{(3c\gamma/2 + j\omega)};$$

$$V_3^{\{P_3^{(0,\beta)}(\tau,\gamma)\}}(j\omega) = \frac{(c\gamma)^{\beta+1}(\beta+7)(\beta+3)!}{6 \prod_{p=0}^{\beta} ((2p+7)c\gamma/2 + j\omega)} \frac{(c\gamma/2 - j\omega)}{(c\gamma/2 + j\omega)} \times \frac{(3c\gamma/2 - j\omega)(5c\gamma/2 - j\omega)}{(3c\gamma/2 + j\omega)(5c\gamma/2 + j\omega)};$$

$$V_4^{\{P_4^{(0,\beta)}(\tau,\gamma)\}}(j\omega) = \frac{(c\gamma)^{\beta+1}(\beta+9)(\beta+4)!}{24 \prod_{p=0}^{\beta} ((2p+9)c\gamma/2 + j\omega)} \frac{(c\gamma/2 - j\omega)}{(c\gamma/2 + j\omega)} \times \frac{(3c\gamma/2 - j\omega)(5c\gamma/2 - j\omega)(7c\gamma/2 - j\omega)}{(3c\gamma/2 + j\omega)(5c\gamma/2 + j\omega)(7c\gamma/2 + j\omega)};$$

$$V_5^{\{P_5^{(0,\beta)}(\tau,\gamma)\}}(j\omega) = \frac{(c\gamma)^{\beta+1}(\beta+11)(\beta+5)!}{120 \prod_{p=0}^{\beta} ((2p+11)c\gamma/2 + j\omega)} \frac{(c\gamma/2 - j\omega)}{(c\gamma/2 + j\omega)} \times \frac{(3c\gamma/2 - j\omega)(5c\gamma/2 - j\omega)(7c\gamma/2 - j\omega)(9c\gamma/2 - j\omega)}{(3c\gamma/2 + j\omega)(5c\gamma/2 + j\omega)(7c\gamma/2 + j\omega)(9c\gamma/2 + j\omega)}.$$



Рис. 6.26. Вид преобразования Фурье ортогональных фильтров Якоби 2-ого порядка: а)  $\gamma = 1, c = 2, \alpha = 0, \beta \in [0; 5]$ ; б)  $\gamma \in [1; 3, 5], c = 2, \alpha = 0, \beta = 1$

### 6.3 Преобразование Фурье производных ортогональных функций

$$[6.75] \quad W_k^{\{1\}\{\frac{\partial L_k(\tau,\gamma)}{\partial \tau}\}}(j\omega) = \frac{j\omega}{j\omega + \gamma/2} \sum_{s=0}^k \binom{k}{k-s} \left(\frac{-\gamma}{j\omega + \gamma/2}\right)^s - 1.$$

$$[6.76] \quad W_k^{\{2\}\{\frac{\partial L_k(\tau,\gamma)}{\partial \tau}\}}(j\omega) = \frac{j\omega}{j\omega + \gamma/2} \left(\frac{j\omega - \gamma/2}{j\omega + \gamma/2}\right)^k - 1.$$

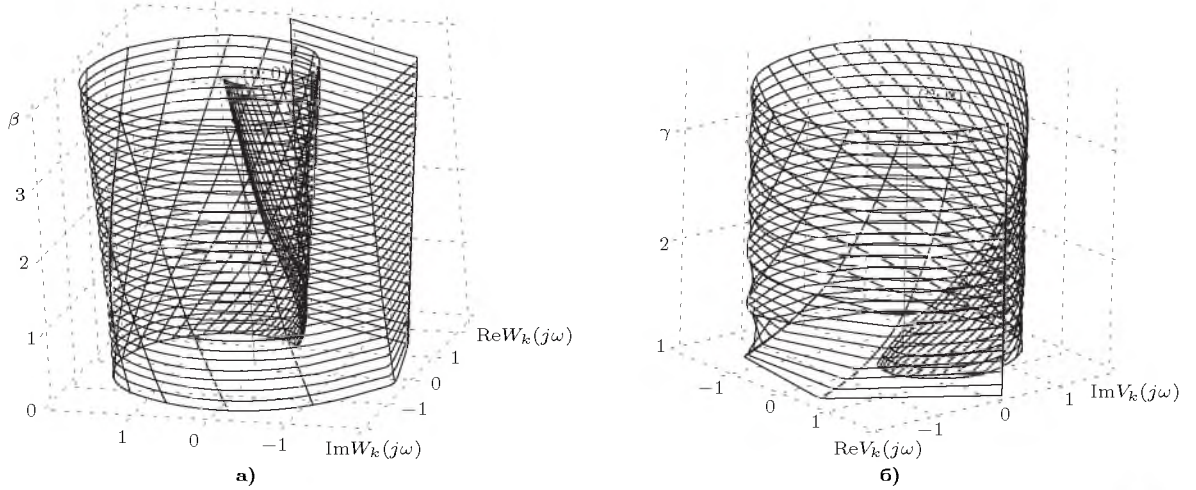
$$[6.77] \quad W_k^{\{3\}\{\frac{\partial L_k(\tau,\gamma)}{\partial \tau}\}}(j\omega) = (-1)^k j \sin \varphi \times \exp(-j(2k+1)\varphi) - 1, \quad \varphi = \arctan \frac{2\omega}{\gamma}.$$

Частные случаи для преобразования Фурье производных функций 0-5 порядков:

$$W_0^{\{\frac{\partial L_0(\tau,\gamma)}{\partial \tau}\}}(j\omega) = -\frac{\gamma/2}{j\omega + \gamma/2};$$

$$W_1^{\{\frac{\partial L_1(\tau,\gamma)}{\partial \tau}\}}(j\omega) = \frac{j\omega(j\omega - \gamma/2)}{(j\omega + \gamma/2)^2} - 1;$$

$$W_2^{\{\frac{\partial L_2(\tau,\gamma)}{\partial \tau}\}}(j\omega) = \frac{j\omega(j\omega - \gamma/2)^2}{(j\omega + \gamma/2)^3} - 1;$$

$$W_3^{\{\frac{\partial L_3(\tau,\gamma)}{\partial \tau}\}}(j\omega) = \frac{j\omega(j\omega - \gamma/2)^3}{(j\omega + \gamma/2)^4} - 1;$$

$$W_4^{\{\frac{\partial L_4(\tau,\gamma)}{\partial \tau}\}}(j\omega) = \frac{j\omega(j\omega - \gamma/2)^4}{(j\omega + \gamma/2)^5} - 1;$$

$$W_5^{\{\frac{\partial L_5(\tau,\gamma)}{\partial \tau}\}}(j\omega) = \frac{j\omega(j\omega - \gamma/2)^5}{(j\omega + \gamma/2)^6} - 1.$$



Рис. 6.27. Вид преобразования Фурье производных ортогональных функций Лагерра 0-5 порядков;  $\gamma = 1$



Рис. 6.28. Вид преобразования Фурье производных ортогональных функций Сонина-Лагерра 0-5 порядков;  $\gamma = 1, \alpha = 1$

$$[6.78] \quad W_k^{[1]}\left\{\frac{\partial L_k^{(1)}(\tau, \gamma)}{\partial \tau}\right\}(j\omega) = \frac{j\omega}{j\omega + \gamma/2} \sum_{s=0}^k \binom{k+1}{k-s} \left(\frac{-\gamma}{j\omega + \gamma/2}\right)^s - (k+1).$$

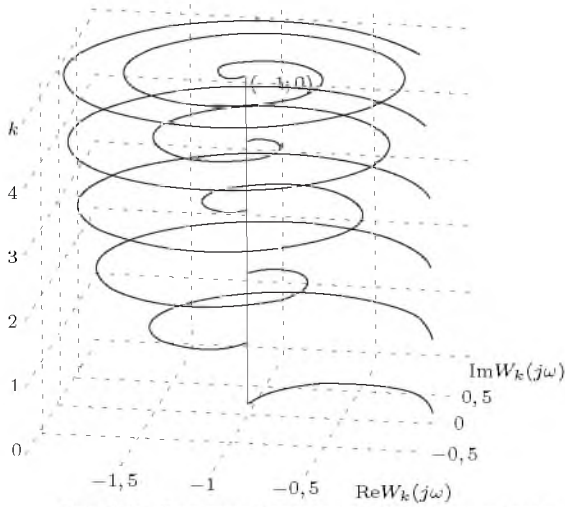
$$[6.79] \quad W_k^{[2]}\left\{\frac{\partial L_k^{(1)}(\tau, \gamma)}{\partial \tau}\right\}(j\omega) = \frac{j\omega}{\gamma} \left(1 - \left(\frac{j\omega - \gamma/2}{j\omega + \gamma/2}\right)^{k+1}\right) - (k+1).$$

$$[6.80] \quad W_k^{[3]}\left\{\frac{\partial L_k^{(1)}(\tau, \gamma)}{\partial \tau}\right\}(j\omega) = \frac{j \tan(\varphi)}{2} \times \left(1 + (-1)^k \exp(-j(2k+2)\varphi)\right) - (k+1), \quad \varphi = \arctan \frac{2\omega}{\gamma}.$$

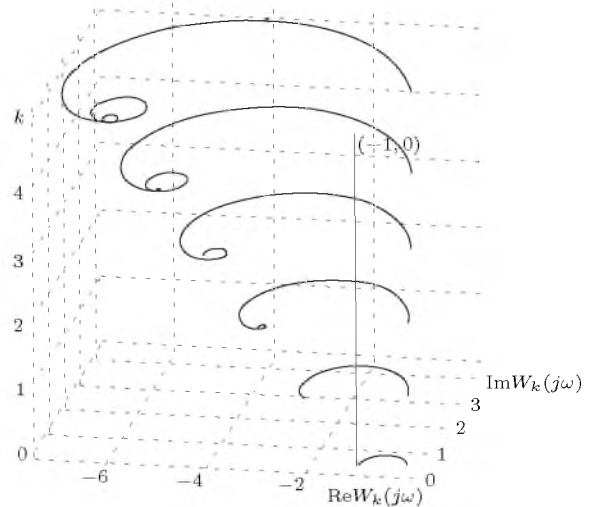
Частные случаи для преобразования Фурье производных функций 0-5 порядков:

$$W_0\left\{\frac{\partial L_0^{(1)}(\tau, \gamma)}{\partial \tau}\right\}(j\omega) = -\frac{\gamma/2}{j\omega + \gamma/2};$$

$$W_1\left\{\frac{\partial L_1^{(1)}(\tau, \gamma)}{\partial \tau}\right\}(j\omega) = -\frac{2\omega^2}{(j\omega + \gamma/2)^2} - 2;$$

$$W_2\left\{\frac{\partial L_2^{(1)}(\tau, \gamma)}{\partial \tau}\right\}(j\omega) = \frac{j\omega(\gamma^2/4 - 3\omega^2)}{(j\omega + \gamma/2)^2} - 3;$$

$$W_3\left\{\frac{\partial L_3^{(1)}(\tau, \gamma)}{\partial \tau}\right\}(j\omega) = \frac{j\omega(\gamma^2 j\omega - 4j\omega^3)}{(j\omega + \gamma/2)^4} - 4;$$

$$W_4\left\{\frac{\partial L_4^{(1)}(\tau, \gamma)}{\partial \tau}\right\}(j\omega) = \frac{j\omega(\gamma^4/16 - 5\gamma^2\omega^2/2 + 5\omega^4)}{(j\omega + \gamma/2)^5} - 5;$$

$$W_5\left\{\frac{\partial L_5^{(1)}(\tau, \gamma)}{\partial \tau}\right\}(j\omega) = \frac{j\omega(3\gamma^4 j\omega/8 - 5\gamma^2 j\omega^3 + 6j\omega^4)}{(j\omega + \gamma/2)^6} - 6.$$

$$[6.81] \quad W_k^{[1]}\left\{\frac{\partial L_k^{(2)}(\tau, \gamma)}{\partial \tau}\right\}(j\omega) = \frac{j\omega}{j\omega + \gamma/2} \sum_{s=0}^k \binom{k+2}{k-s} \left(\frac{-\gamma}{j\omega + \gamma/2}\right)^s - \frac{(k+1)(k+2)}{2}.$$

$$[6.82] \quad W_k^{[2]}\left\{\frac{\partial L_k^{(2)}(\tau, \gamma)}{\partial \tau}\right\}(j\omega) = \frac{j\omega}{\gamma^2} \times \left[ \left( \left(\frac{j\omega - \gamma/2}{j\omega + \gamma/2}\right)^{k+1} - 1 \right) (j\omega - \gamma/2) + \gamma(k+1) \right] - \frac{(k+1)(k+2)}{2}.$$

$$[6.83] \quad W_k^{[3]}\left\{\frac{\partial L_k^{(2)}(\tau, \gamma)}{\partial \tau}\right\}(j\omega) = \frac{j \tan(\varphi)}{2} \times \left( \frac{(-1)^k \exp(-j(2k+3)\varphi) - \exp(-j\varphi)}{2 \cos \varphi} + k+1 \right) - \frac{(k+1)(k+2)}{2}, \quad \varphi = \arctan \frac{2\omega}{\gamma}.$$

Частные случаи для преобразования Фурье производных функций 0-5 порядков:

$$W_0\left\{\frac{\partial L_0^{(2)}(\tau, \gamma)}{\partial \tau}\right\}(j\omega) = -\frac{\gamma/2}{j\omega + \gamma/2};$$

$$W_1\left\{\frac{\partial L_1^{(2)}(\tau, \gamma)}{\partial \tau}\right\}(j\omega) = \frac{j\omega(\gamma/2 + 3j\omega)}{(j\omega + \gamma/2)^2} - 3;$$

$$W_2\left\{\frac{\partial L_2^{(2)}(\tau, \gamma)}{\partial \tau}\right\}(j\omega) = \frac{j\omega(\gamma^2/2 + 2\gamma j\omega - 6\omega^2)}{(j\omega + \gamma/2)^3} - 6;$$

$$W_3\left\{\frac{\partial L_3^{(2)}(\tau, \gamma)}{\partial \tau}\right\}(j\omega) = \frac{j\omega(\gamma^3/4 + 5\gamma^2 j\omega/2 - 5\gamma\omega^2 - 10j\omega^3)}{(j\omega + \gamma/2)^4} -$$

- 10;

$$W_4^{\left\{ \frac{\partial L_4^{(2)}(\tau, \gamma)}{\partial \tau} \right\}}(j\omega) = \frac{j\omega}{(j\omega + \gamma/2)^5} (3\gamma^4/16 + 3\gamma^3 j\omega/2 - 15\gamma^2 \omega^2/2 - 10\gamma j\omega^3 + 15\omega^4) - 15;$$

$$W_5^{\left\{ \frac{\partial L_5^{(2)}(\tau, \gamma)}{\partial \tau} \right\}}(j\omega) = \frac{j\omega}{(j\omega + \gamma/2)^6} (3\gamma^5/32 + 21\gamma^4 j\omega/16 - 21\gamma^3 \omega^2/4 - 35\gamma^2 j\omega^3/2 + 35\gamma \omega^4/2 + 21j\omega^5) - 21.$$



Рис. 6.29. Вид преобразования Фурье производных ортогональных функций Сонина-Лагерра 0-5 порядков;  $\gamma = 1, \alpha = 2$

[6.84]  $W_k^{[1]}\left\{ \frac{\partial L_k^{(\alpha)}(\tau, \gamma)}{\partial \tau} \right\}(j\omega) = \frac{j\omega}{j\omega + \gamma/2} \sum_{s=0}^k \binom{k+\alpha}{k-s} \left( \frac{-\gamma}{j\omega + \gamma/2} \right)^s - \binom{k+\alpha}{k}.$

[6.85]  $W_k^{[2]}\left\{ \frac{\partial L_k^{(\alpha)}(\tau, \gamma)}{\partial \tau} \right\}(j\omega) = \frac{j\omega (j\omega - \gamma/2)^{\alpha-1}}{(-\gamma)^\alpha} \left[ \left( \frac{j\omega - \gamma/2}{j\omega + \gamma/2} \right)^{k+\alpha} - \sum_{p=0}^{\alpha-1} \binom{k+\alpha}{p} \left( -\frac{\gamma}{j\omega + \gamma/2} \right)^p \right] - \binom{k+\alpha}{k}, \quad \alpha \in \mathbb{Z}.$

Частные случаи для преобразования Фурье производных функций 0-5 порядков:

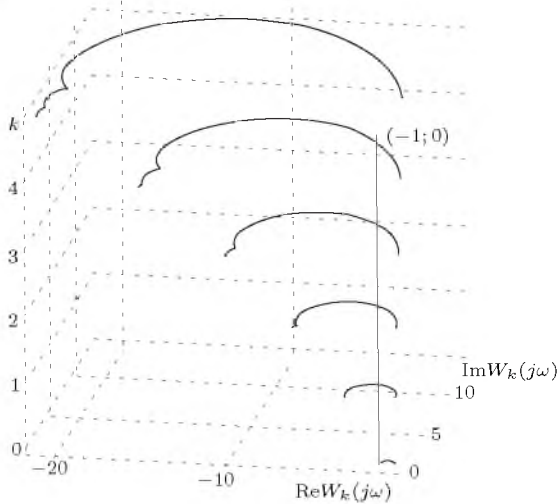
$$W_0^{\left\{ \frac{\partial L_0^{(\alpha)}(\tau, \gamma)}{\partial \tau} \right\}}(j\omega) = -\frac{\gamma/2}{j\omega + \gamma/2};$$

$$W_1^{\left\{ \frac{\partial L_1^{(\alpha)}(\tau, \gamma)}{\partial \tau} \right\}}(j\omega) = \frac{j\omega(\gamma(\alpha-1)/2 + j\omega(\alpha+1))}{(j\omega + \gamma/2)^2} - \alpha - 1;$$

$$W_2^{\left\{ \frac{\partial L_2^{(\alpha)}(\tau, \gamma)}{\partial \tau} \right\}}(j\omega) = \frac{j\omega}{(j\omega + \gamma/2)^3} (\gamma^2(\alpha^2 + \alpha - 2)/8 + \gamma j\omega(\alpha^2 - \alpha + 2)/2 - \omega^2(\alpha^2 + 3\alpha + 2)/2) - (\alpha + 1)(\alpha + 2)/2;$$

$$W_3^{\left\{ \frac{\partial L_3^{(\alpha)}(\tau, \gamma)}{\partial \tau} \right\}}(j\omega) = \frac{j\omega}{(j\omega + \gamma/2)^4} (-\gamma^3 + \gamma^2(j\omega + \gamma/2)(\alpha + 3) - \gamma(j\omega + \gamma/2)^2(\alpha + 2)(\alpha + 3)/2 - (j\omega + \gamma/2)^3(\alpha + 3)/(6\alpha!)) - (\alpha + 1)(\alpha + 2)(\alpha + 3)/6;$$

$$W_4^{\left\{ \frac{\partial L_4^{(\alpha)}(\tau, \gamma)}{\partial \tau} \right\}}(j\omega) = \frac{j\omega}{(j\omega + \gamma/2)^5} (\gamma^4 - \gamma^3(j\omega + \gamma/2)(\alpha + 4) + \gamma^2(j\omega + \gamma/2)^2(\alpha + 3)(\alpha + 4)/2 - \gamma(j\omega + \gamma/2)^3(\alpha + 4)/(6(\alpha + 1)! + (j\omega + \gamma/2)^4(\alpha + 4)/(24\alpha!)) - (\alpha + 1)(\alpha + 2)(\alpha + 3) \times (\alpha + 4)/24);$$

$$W_5^{\left\{ \frac{\partial L_5^{(\alpha)}(\tau, \gamma)}{\partial \tau} \right\}}(j\omega) = \frac{j\omega}{(j\omega + \gamma/2)^6} (-\gamma^5 + \gamma^4(j\omega + \gamma/2)(\alpha + 5) - \gamma^3(j\omega + \gamma/2)^2(\alpha + 4)(\alpha + 5)/2 + \gamma^2(j\omega + \gamma/2)^3(\alpha + 5)/(6(\alpha + 2)! - \gamma(j\omega + \gamma/2)^4(\alpha + 5)/(24(\alpha + 1)! + (j\omega + \gamma/2)^5 \times (\alpha + 5)/(120\alpha!)) - (\alpha + 1)(\alpha + 2)(\alpha + 3)(\alpha + 4)(\alpha + 5)/120).$$



Рис. 6.30. Вид преобразования Фурье производных ортогональных функций Сонина-Лагерра 2-ого порядка: а)  $\gamma = 1, \alpha \in [0; 5]$ ; б)  $\gamma \in [1; 5], \alpha = 1$

$$[6.86] \quad W_k^{[1]} \left\{ \frac{\partial P_k^{(-1/2,0)}(\tau, \gamma)}{\partial \tau} \right\} (j\omega) = j\omega \sum_{s=0}^k \binom{k}{s} \times \\ \times \binom{k+s-1/2}{s-1/2} (-1)^s \frac{1}{(4s+1)\gamma/2 + j\omega} - (-1)^k.$$

$$[6.87] \quad W_k^{[2]} \left\{ \frac{\partial P_k^{(-1/2,0)}(\tau, \gamma)}{\partial \tau} \right\} (j\omega) = \\ = \begin{cases} \frac{j\omega}{\gamma/2 + j\omega} - 1, & \text{если } k = 0; \\ \frac{j\omega}{(4k+1)\gamma/2 + j\omega} \times \\ \times \prod_{s=0}^{k-1} \frac{(4s+1)\gamma/2 - j\omega}{(4s+1)\gamma/2 + j\omega} - (-1)^k, & \text{если } k > 0. \end{cases}$$

$$[6.88] \quad W_k^{[3]} \left\{ \frac{\partial P_k^{(-1/2,0)}(\tau, \gamma)}{\partial \tau} \right\} (j\omega) = \\ = \begin{cases} j \sin \varphi_0 \exp(-j\varphi_0) - 1, & \text{если } k = 0; \\ j \sin \varphi_k \exp \left( -j \left( \varphi_k + \right. \right. \\ \left. \left. + 2 \sum_{s=0}^{k-1} \varphi_s \right) \right) - (-1)^k, & \text{если } k > 0, \end{cases} \\ \varphi_k = \arctan \frac{2\omega}{(4k+1)\gamma}.$$

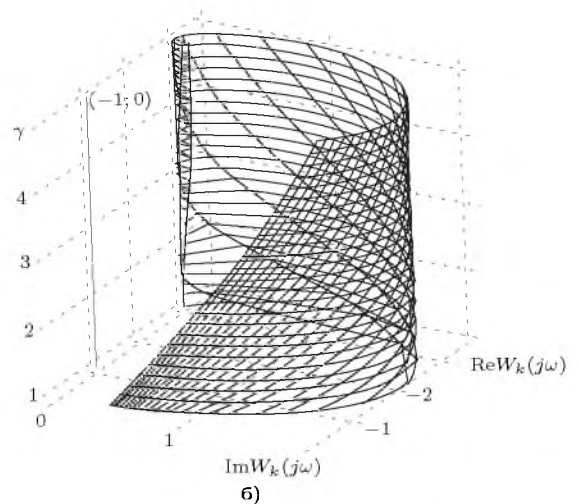
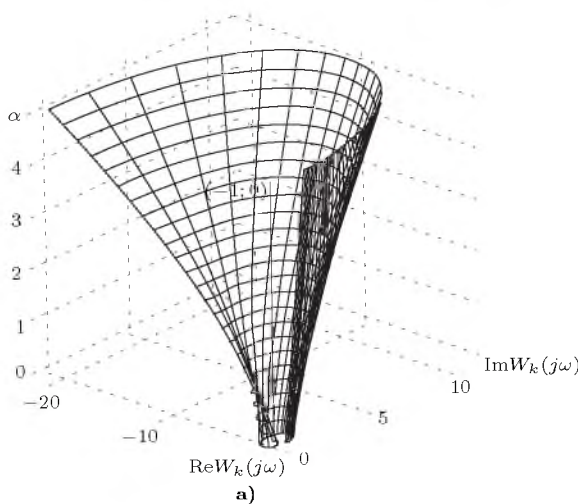
Частные случаи для преобразования Фурье производных функций 0-5 порядков:

$$W_0 \left\{ \frac{\partial P_0^{(-1/2,0)}(\tau, \gamma)}{\partial \tau} \right\} (j\omega) = -\frac{\gamma/2}{\gamma/2 + j\omega}; \\ W_1 \left\{ \frac{\partial P_1^{(-1/2,0)}(\tau, \gamma)}{\partial \tau} \right\} (j\omega) = \frac{j\omega(\gamma/2 - j\omega)}{(\gamma/2 + j\omega)(5\gamma/2 + j\omega)} + 1; \\ W_2 \left\{ \frac{\partial P_2^{(-1/2,0)}(\tau, \gamma)}{\partial \tau} \right\} (j\omega) = \frac{j\omega(\gamma/2 - j\omega)(5\gamma/2 - j\omega)}{(\gamma/2 + j\omega)(5\gamma/2 + j\omega)(9\gamma/2 + j\omega)} - 1; \\ W_3 \left\{ \frac{\partial P_3^{(-1/2,0)}(\tau, \gamma)}{\partial \tau} \right\} (j\omega) = \frac{j\omega(\gamma/2 - j\omega)}{(13\gamma/2 + j\omega)(\gamma/2 + j\omega)} \times \\ \times \frac{(5\gamma/2 - j\omega)(9\gamma/2 - j\omega)}{(5\gamma/2 + j\omega)(9\gamma/2 + j\omega)} + 1; \\ W_4 \left\{ \frac{\partial P_4^{(-1/2,0)}(\tau, \gamma)}{\partial \tau} \right\} (j\omega) = \frac{j\omega(\gamma/2 - j\omega)}{(17\gamma/2 + j\omega)(\gamma/2 + j\omega)} \times \\ \times \frac{(5\gamma/2 - j\omega)(9\gamma/2 - j\omega)(13\gamma/2 - j\omega)}{(5\gamma/2 + j\omega)(9\gamma/2 + j\omega)(13\gamma/2 + j\omega)} - 1; \\ W_5 \left\{ \frac{\partial P_5^{(-1/2,0)}(\tau, \gamma)}{\partial \tau} \right\} (j\omega) = \frac{j\omega(\gamma/2 - j\omega)}{(21\gamma/2 + j\omega)(\gamma/2 + j\omega)} \times \\ \times \frac{(5\gamma/2 - j\omega)(9\gamma/2 - j\omega)(13\gamma/2 - j\omega)(17\gamma/2 - j\omega)}{(5\gamma/2 + j\omega)(9\gamma/2 + j\omega)(13\gamma/2 + j\omega)(17\gamma/2 + j\omega)} + 1.$$



Рис. 6.31. Вид преобразования Фурье производных ортогональных функций Якоби 0-5 порядков;  $\gamma = 0,25$ ,  $c = 2$ ,  $\alpha = -1/2$ ,  $\beta = 0$

$$[6.89] \quad W_k^{[1]} \left\{ \frac{\partial Leg_k(\tau, \gamma)}{\partial \tau} \right\} (j\omega) = \\ = j\omega \sum_{s=0}^k \binom{k}{s} \binom{k+s}{s} (-1)^s \frac{1}{(2s+1)\gamma + j\omega} - (-1)^k.$$

$$[6.90] \quad W_k^{[2]} \left\{ \frac{\partial Leg_k(\tau, \gamma)}{\partial \tau} \right\} (j\omega) = \\ = \begin{cases} \frac{j\omega}{\gamma + j\omega} - 1, & \text{если } k = 0; \\ \frac{j\omega}{(2k+1)\gamma + j\omega} \times \\ \times \prod_{s=0}^{k-1} \frac{(2s+1)\gamma - j\omega}{(2s+1)\gamma + j\omega} - (-1)^k, & \text{если } k > 0. \end{cases}$$

$$[6.91] \quad W_k^{[3]} \left\{ \frac{\partial Leg_k(\tau, \gamma)}{\partial \tau} \right\} (j\omega) = \\ = \begin{cases} j \sin \varphi_0 \exp(-j\varphi_0) - 1, & \text{если } k = 0; \\ j \sin \varphi_k \exp \left( -j \left( \varphi_k + \right. \right. \\ \left. \left. + 2 \sum_{s=0}^{k-1} \varphi_s \right) \right) - (-1)^k, & \text{если } k > 0, \end{cases} \\ \varphi_k = \arctan \frac{\omega}{(2k+1)\gamma}.$$

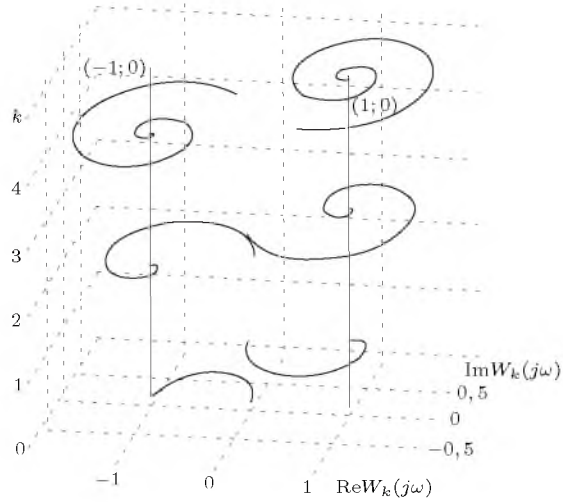
Частные случаи для преобразования Фурье производных функций 0-5 порядков:

$$W_0 \left\{ \frac{\partial Leg_0(\tau, \gamma)}{\partial \tau} \right\} (j\omega) = -\frac{\gamma}{\gamma + j\omega}; \\ W_1 \left\{ \frac{\partial Leg_1(\tau, \gamma)}{\partial \tau} \right\} (j\omega) = \frac{j\omega(\gamma - j\omega)}{(\gamma + j\omega)(3\gamma + j\omega)} + 1; \\ W_2 \left\{ \frac{\partial Leg_2(\tau, \gamma)}{\partial \tau} \right\} (j\omega) = \frac{j\omega(\gamma - j\omega)(3\gamma - j\omega)}{(\gamma + j\omega)(3\gamma + j\omega)(5\gamma + j\omega)} - 1; \\ W_3 \left\{ \frac{\partial Leg_3(\tau, \gamma)}{\partial \tau} \right\} (j\omega) = \frac{j\omega(\gamma - j\omega)(3\gamma - j\omega)(5\gamma - j\omega)}{(\gamma + j\omega)(3\gamma + j\omega)(5\gamma + j\omega)(7\gamma + j\omega)} + 1;$$



$$W_4^{\left\{ \frac{\partial \text{Leg}_4(\tau, \gamma)}{\partial \tau} \right\}}(j\omega) = \frac{j\omega}{(9\gamma + j\omega)} \frac{(\gamma - j\omega)(3\gamma - j\omega)}{(\gamma + j\omega)(3\gamma + j\omega)} \times$$

$$\times \frac{(5\gamma - j\omega)(7\gamma - j\omega)}{(5\gamma + j\omega)(7\gamma + j\omega)} - 1;$$

$$W_5^{\left\{ \frac{\partial \text{Leg}_5(\tau, \gamma)}{\partial \tau} \right\}}(j\omega) = \frac{j\omega}{(11\gamma + j\omega)} \frac{(\gamma - j\omega)(3\gamma - j\omega)}{(\gamma + j\omega)(3\gamma + j\omega)} \times$$

$$\times \frac{(5\gamma - j\omega)(7\gamma - j\omega)(9\gamma - j\omega)}{(5\gamma + j\omega)(7\gamma + j\omega)(9\gamma + j\omega)} + 1.$$



Рис. 6.32. Вид преобразования Фурье производных ортогональных функций Лежандра 0-5 порядков;  $\gamma = 0,25$ ,  $c = 2$

[6.92] 
$$W_k^{[1]}\left\{ \frac{\partial P_k^{(1/2,0)}(\tau, \gamma)}{\partial \tau} \right\}(j\omega) = j\omega \sum_{s=0}^k \binom{k}{s} \times$$

$$\times \binom{k+s+1/2}{s+1/2} (-1)^s \frac{1}{(4s+3)\gamma/2 + j\omega} - (-1)^k.$$

[6.93] 
$$W_k^{[2]}\left\{ \frac{\partial P_k^{(1/2,0)}(\tau, \gamma)}{\partial \tau} \right\}(j\omega) =$$

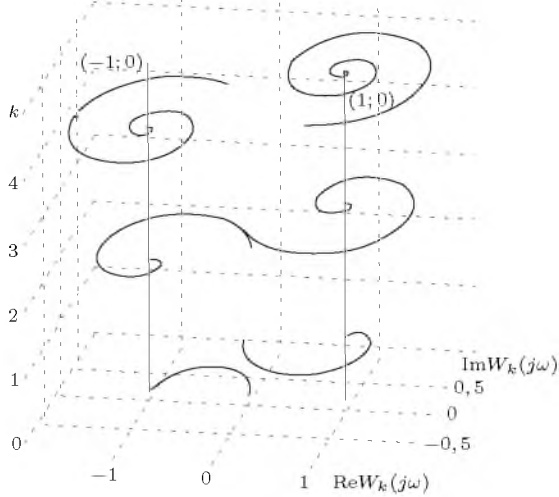
$$= \begin{cases} \frac{j\omega}{3\gamma/2 + j\omega} - 1, & \text{если } k = 0; \\ \frac{j\omega}{(4k+3)\gamma/2 + j\omega} \times \\ \times \prod_{s=0}^{k-1} \frac{(4s+3)\gamma/2 - j\omega}{(4s+3)\gamma/2 + j\omega} - (-1)^k, & \text{если } k > 0. \end{cases}$$

[6.94] 
$$W_k^{[3]}\left\{ \frac{\partial P_k^{(1/2,0)}(\tau, \gamma)}{\partial \tau} \right\}(j\omega) =$$

$$= \begin{cases} j \sin \varphi_0 \exp(-j\varphi_0) - 1, & \text{если } k = 0; \\ j \sin \varphi_k \exp\left(-j\left(\varphi_k + \right. \right. \\ \left. \left. + 2 \sum_{s=0}^{k-1} \varphi_s\right)\right) - (-1)^k, & \text{если } k > 0, \end{cases}$$

$$\varphi_k = \arctan \frac{2\omega}{(4k+3)\gamma}.$$

Частные случаи для преобразования Фурье производных функций 0-5 порядков:

$$W_0^{\left\{ \frac{\partial P_0^{(1/2,0)}(\tau, \gamma)}{\partial \tau} \right\}}(j\omega) = -\frac{3\gamma/2}{3\gamma/2 + j\omega};$$

$$W_1^{\left\{ \frac{\partial P_1^{(1/2,0)}(\tau, \gamma)}{\partial \tau} \right\}}(j\omega) = \frac{j\omega(3\gamma/2 - j\omega)}{(3\gamma/2 + j\omega)(7\gamma/2 + j\omega)} + 1;$$

$$W_2^{\left\{ \frac{\partial P_2^{(1/2,0)}(\tau, \gamma)}{\partial \tau} \right\}}(j\omega) = \frac{j\omega(3\gamma/2 - j\omega)(7\gamma/2 - j\omega)}{(3\gamma/2 + j\omega)(7\gamma/2 + j\omega)} \times$$

$$\times \frac{1}{(11\gamma/2 + j\omega)} - 1;$$

$$W_3^{\left\{ \frac{\partial P_3^{(1/2,0)}(\tau, \gamma)}{\partial \tau} \right\}}(j\omega) = \frac{j\omega}{(15\gamma/2 + j\omega)} \frac{(3\gamma/2 - j\omega)}{(3\gamma/2 + j\omega)} \times$$

$$\times \frac{(7\gamma/2 - j\omega)(11\gamma/2 - j\omega)}{(7\gamma/2 + j\omega)(11\gamma/2 + j\omega)} + 1;$$

$$W_4^{\left\{ \frac{\partial P_4^{(1/2,0)}(\tau, \gamma)}{\partial \tau} \right\}}(j\omega) = \frac{j\omega}{(19\gamma/2 + j\omega)} \frac{(3\gamma/2 - j\omega)}{(3\gamma/2 + j\omega)} \times$$

$$\times \frac{(7\gamma/2 - j\omega)(11\gamma/2 - j\omega)}{(7\gamma/2 + j\omega)(11\gamma/2 + j\omega)} \frac{(15\gamma/2 - j\omega)}{(15\gamma/2 + j\omega)} - 1;$$

$$W_5^{\left\{ \frac{\partial P_5^{(1/2,0)}(\tau, \gamma)}{\partial \tau} \right\}}(j\omega) = \frac{j\omega}{(23\gamma/2 + j\omega)} \frac{(3\gamma/2 - j\omega)}{(3\gamma/2 + j\omega)} \times$$

$$\times \frac{(7\gamma/2 - j\omega)(11\gamma/2 - j\omega)}{(7\gamma/2 + j\omega)(11\gamma/2 + j\omega)} \frac{(15\gamma/2 - j\omega)(19\gamma/2 - j\omega)}{(15\gamma/2 + j\omega)(19\gamma/2 + j\omega)} + 1.$$



Рис. 6.33. Вид преобразования Фурье производных ортогональных функций Якоби 0-5 порядков;  $\gamma = 0,25$ ,  $c = 2$ ,  $\alpha = 1/2$ ,  $\beta = 0$

[6.95] 
$$W_k^{[1]}\left\{ \frac{\partial P_k^{(1,0)}(\tau, \gamma)}{\partial \tau} \right\}(j\omega) =$$

$$= j\omega \sum_{s=0}^k \binom{k}{s} \binom{k+s+1}{s+1} (-1)^s \frac{1}{(s+1)\gamma + j\omega} - (-1)^k.$$

$$\begin{aligned}
 [6.96] \quad W_k^{[2]} \left\{ \frac{\partial P_k^{(1,0)}(\tau, \gamma)}{\partial \tau} \right\} (j\omega) &= \\
 &= \begin{cases} \frac{j\omega}{\gamma + j\omega} - 1, & \text{если } k = 0; \\ \frac{j\omega}{(k+1)\gamma + j\omega} \times \\ \times \prod_{s=0}^{k-1} \frac{(s+1)\gamma - j\omega}{(s+1)\gamma + j\omega} - (-1)^k, & \text{если } k > 0. \end{cases}
 \end{aligned}$$

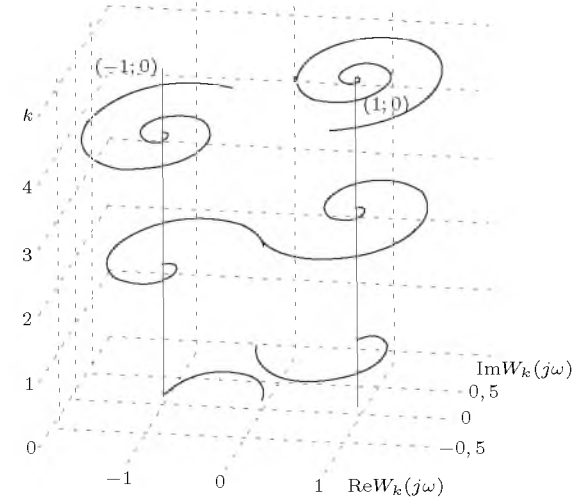
$$\begin{aligned}
 [6.97] \quad W_k^{[3]} \left\{ \frac{\partial P_k^{(1,0)}(\tau, \gamma)}{\partial \tau} \right\} (j\omega) &= \\
 &= \begin{cases} j \sin \varphi_0 \exp(-j\varphi_0) - 1, & \text{если } k = 0; \\ j \sin \varphi_k \exp \left( -j \left( \varphi_k + \right. \right. \\ \left. \left. + 2 \sum_{s=0}^{k-1} \varphi_s \right) \right) - (-1)^k, & \text{если } k > 0, \end{cases} \\
 \varphi_k &= \arctan \frac{\omega}{(k+1)\gamma}.
 \end{aligned}$$

Частные случаи для преобразования Фурье производных функций 0-5 порядков:

$$\begin{aligned}
 W_0 \left\{ \frac{\partial P_0^{(1,0)}(\tau, \gamma)}{\partial \tau} \right\} (j\omega) &= -\frac{\gamma}{\gamma + j\omega}; \\
 W_1 \left\{ \frac{\partial P_1^{(1,0)}(\tau, \gamma)}{\partial \tau} \right\} (j\omega) &= \frac{j\omega(\gamma - j\omega)}{(\gamma + j\omega)(2\gamma + j\omega)} + 1; \\
 W_2 \left\{ \frac{\partial P_2^{(1,0)}(\tau, \gamma)}{\partial \tau} \right\} (j\omega) &= \frac{j\omega(\gamma - j\omega)(2\gamma - j\omega)}{(\gamma + j\omega)(2\gamma + j\omega)(3\gamma + j\omega)} - 1; \\
 W_3 \left\{ \frac{\partial P_3^{(1,0)}(\tau, \gamma)}{\partial \tau} \right\} (j\omega) &= \frac{j\omega(\gamma - j\omega)(2\gamma - j\omega)(3\gamma - j\omega)}{(\gamma + j\omega)(2\gamma + j\omega)(3\gamma + j\omega)(4\gamma + j\omega)} + \\
 &+ 1; \\
 W_4 \left\{ \frac{\partial P_4^{(1,0)}(\tau, \gamma)}{\partial \tau} \right\} (j\omega) &= \frac{j\omega(\gamma - j\omega)(2\gamma - j\omega)(3\gamma - j\omega)}{(5\gamma + j\omega)(\gamma + j\omega)(2\gamma + j\omega)(3\gamma + j\omega)} \times \\
 &\times \frac{(4\gamma - j\omega)}{(4\gamma + j\omega)} - 1; \\
 W_5 \left\{ \frac{\partial P_5^{(1,0)}(\tau, \gamma)}{\partial \tau} \right\} (j\omega) &= \frac{j\omega(\gamma - j\omega)(2\gamma - j\omega)(3\gamma - j\omega)}{(6\gamma + j\omega)(\gamma + j\omega)(2\gamma + j\omega)(3\gamma + j\omega)} \times \\
 &\times \frac{(4\gamma - j\omega)(5\gamma - j\omega)}{(4\gamma + j\omega)(5\gamma + j\omega)} + 1.
 \end{aligned}$$



Рис. 6.34. Вид преобразования Фурье производных ортогональных функций Якоби 0-5 порядков;  $\gamma = 0,25, c = 1, \alpha = 1, \beta = 0$

$$\begin{aligned}
 [6.98] \quad W_k^{[1]} \left\{ \frac{\partial P_k^{(2,0)}(\tau, \gamma)}{\partial \tau} \right\} (j\omega) &= \\
 &= j\omega \sum_{s=0}^k \binom{k}{s} \binom{k+s+2}{s+2} (-1)^s \frac{1}{(2s+3)\gamma + j\omega} - (-1)^k.
 \end{aligned}$$

$$\begin{aligned}
 [6.99] \quad W_k^{[2]} \left\{ \frac{\partial P_k^{(2,0)}(\tau, \gamma)}{\partial \tau} \right\} (j\omega) &= \\
 &= \begin{cases} \frac{j\omega}{3\gamma + j\omega} - 1, & \text{если } k = 0; \\ \frac{j\omega}{(2k+3)\gamma + j\omega} \times \\ \times \prod_{s=0}^{k-1} \frac{(2s+3)\gamma - j\omega}{(2s+3)\gamma + j\omega} - (-1)^k, & \text{если } k > 0. \end{cases}
 \end{aligned}$$

$$\begin{aligned}
 [6.100] \quad W_k^{[3]} \left\{ \frac{\partial P_k^{(2,0)}(\tau, \gamma)}{\partial \tau} \right\} (j\omega) &= \\
 &= \begin{cases} j \sin \varphi_0 \exp(-j\varphi_0) - 1, & \text{если } k = 0; \\ j \sin \varphi_k \times \\ \exp \left( -j \left( \varphi_k + \right. \right. \\ \left. \left. + 2 \sum_{s=0}^{k-1} \varphi_s \right) \right) - (-1)^k, & \text{если } k > 0, \end{cases} \\
 \varphi_k &= \arctan \frac{\omega}{(2k+3)\gamma}.
 \end{aligned}$$

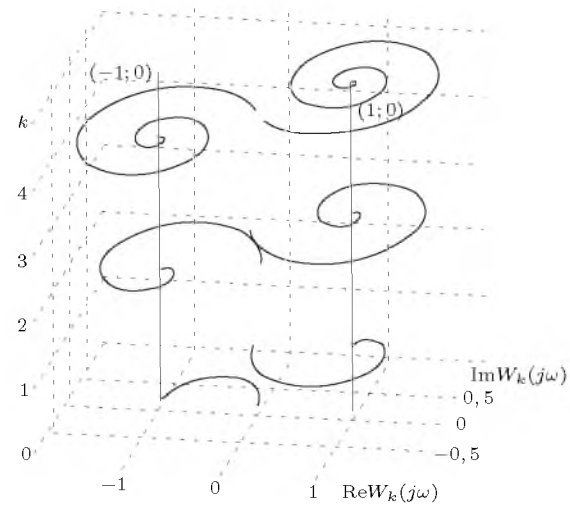
Частные случаи для преобразования Фурье производных функций 0-5 порядков:

$$\begin{aligned}
 W_0 \left\{ \frac{\partial P_0^{(2,0)}(\tau, \gamma)}{\partial \tau} \right\} (j\omega) &= -\frac{3\gamma}{3\gamma + j\omega}; \\
 W_1 \left\{ \frac{\partial P_1^{(2,0)}(\tau, \gamma)}{\partial \tau} \right\} (j\omega) &= \frac{j\omega(3\gamma - j\omega)}{(3\gamma + j\omega)(5\gamma + j\omega)} + 1;
 \end{aligned}$$

$$W_2 \left\{ \frac{\partial P_2^{(2,0)}(\tau, \gamma)}{\partial \tau} \right\} (j\omega) = \frac{j\omega(3\gamma - j\omega)(5\gamma - j\omega)}{(3\gamma + j\omega)(5\gamma + j\omega)(7\gamma + j\omega)} - 1;$$

$$W_3 \left\{ \frac{\partial P_3^{(2,0)}(\tau, \gamma)}{\partial \tau} \right\} (j\omega) = \frac{j\omega}{(9\gamma + j\omega)} \frac{(3\gamma - j\omega)(5\gamma - j\omega)(7\gamma - j\omega)}{(3\gamma + j\omega)(5\gamma + j\omega)(7\gamma + j\omega)} +$$

$$+ 1;$$

$$W_4 \left\{ \frac{\partial P_4^{(2,0)}(\tau, \gamma)}{\partial \tau} \right\} (j\omega) = \frac{j\omega}{(11\gamma + j\omega)} \frac{(3\gamma - j\omega)(5\gamma - j\omega)}{(3\gamma + j\omega)(5\gamma + j\omega)} \times$$

$$\times \frac{(7\gamma - j\omega)(9\gamma - j\omega)}{(7\gamma + j\omega)(9\gamma + j\omega)} - 1;$$

$$W_5 \left\{ \frac{\partial P_5^{(2,0)}(\tau, \gamma)}{\partial \tau} \right\} (j\omega) = \frac{j\omega}{(13\gamma + j\omega)} \frac{(3\gamma - j\omega)(5\gamma - j\omega)}{(3\gamma + j\omega)(5\gamma + j\omega)} \times$$

$$\times \frac{(7\gamma - j\omega)(9\gamma - j\omega)(11\gamma - j\omega)}{(7\gamma + j\omega)(9\gamma + j\omega)(11\gamma + j\omega)} + 1.$$



Рис. 6.35. Вид преобразования Фурье производных ортогональных функций Якоби 0-5 порядков;  $\gamma = 0,25, c = 2, \alpha = 2, \beta = 0$

$$[6.101] \quad W_k^{[1]} \left\{ \frac{\partial P_k^{(\alpha,0)}(\tau, \gamma)}{\partial \tau} \right\} (j\omega) = j\omega \sum_{s=0}^k \binom{k}{s} \times$$

$$\times \binom{k+s+\alpha}{s+\alpha} (-1)^s \frac{1}{(2s+\alpha+1)c\gamma/2 + j\omega} - (-1)^k.$$

$$[6.102] \quad W_k^{[2]} \left\{ \frac{\partial P_k^{(\alpha,0)}(\tau, \gamma)}{\partial \tau} \right\} (j\omega) =$$

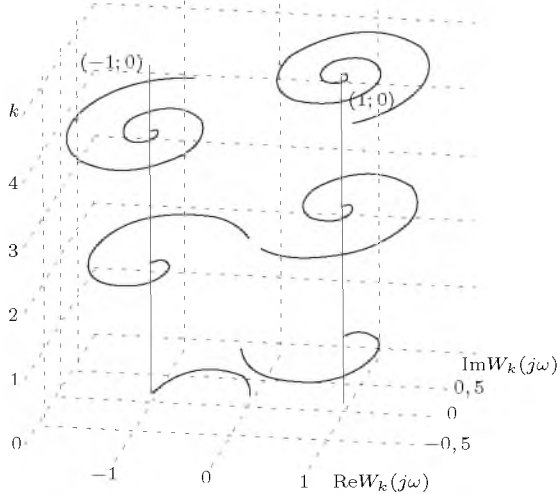
$$\begin{cases} \frac{j\omega}{(\alpha+1)c\gamma/2 + j\omega} - 1, & \text{если } k = 0; \\ \frac{j\omega}{(2k+\alpha+1)c\gamma/2 + j\omega} \times \\ \times \prod_{s=0}^{k-1} \frac{(2s+\alpha+1)c\gamma/2 - j\omega}{(2s+\alpha+1)c\gamma/2 + j\omega} - (-1)^k, & \text{если } k > 0. \end{cases}$$

$$[6.103] \quad W_k^{[3]} \left\{ \frac{\partial P_k^{(\alpha,0)}(\tau, \gamma)}{\partial \tau} \right\} (j\omega) =$$

$$\begin{cases} j \sin \varphi_0 \exp(-j\varphi_0) - 1, & \text{если } k = 0; \\ j \sin \varphi_k \times \\ \times \exp \left( -j \left( \varphi_k + \right. \right. \\ \left. \left. + 2 \sum_{s=0}^{k-1} \varphi_s \right) \right) - (-1)^k, & \text{если } k > 0, \end{cases}$$

$$\varphi_k = \arctan \frac{2\omega}{(2k+\alpha+1)c\gamma}.$$

Частные случаи для преобразования Фурье производных функций 0-5 порядков:

$$W_0 \left\{ \frac{\partial P_0^{(\alpha,0)}(\tau, \gamma)}{\partial \tau} \right\} (j\omega) = -\frac{(\alpha+1)c\gamma/2}{(\alpha+1)c\gamma/2 + j\omega};$$

$$W_1 \left\{ \frac{\partial P_1^{(\alpha,0)}(\tau, \gamma)}{\partial \tau} \right\} (j\omega) = \frac{j\omega((\alpha+1)c\gamma/2 - j\omega)}{((\alpha+1)c\gamma/2 + j\omega)} \times$$

$$\times \frac{1}{((\alpha+3)c\gamma/2 + j\omega)} + 1;$$

$$W_2 \left\{ \frac{\partial P_2^{(\alpha,0)}(\tau, \gamma)}{\partial \tau} \right\} (j\omega) = \frac{j\omega}{((\alpha+5)c\gamma/2 + j\omega)} \times$$

$$\times \frac{((\alpha+1)c\gamma/2 - j\omega)((\alpha+3)c\gamma/2 - j\omega)}{((\alpha+1)c\gamma/2 + j\omega)((\alpha+3)c\gamma/2 + j\omega)} - 1;$$

$$W_3 \left\{ \frac{\partial P_3^{(\alpha,0)}(\tau, \gamma)}{\partial \tau} \right\} (j\omega) = \frac{j\omega}{((\alpha+7)c\gamma/2 + j\omega)} \times$$

$$\times \frac{((\alpha+1)c\gamma/2 - j\omega)((\alpha+3)c\gamma/2 - j\omega)((\alpha+5)c\gamma/2 - j\omega)}{((\alpha+1)c\gamma/2 + j\omega)((\alpha+3)c\gamma/2 + j\omega)((\alpha+5)c\gamma/2 + j\omega)} + 1;$$

$$W_4 \left\{ \frac{\partial P_4^{(\alpha,0)}(\tau, \gamma)}{\partial \tau} \right\} (j\omega) = \frac{j\omega}{((\alpha+9)c\gamma/2 + j\omega)} \times$$

$$\times \frac{((\alpha+1)c\gamma/2 - j\omega)((\alpha+3)c\gamma/2 - j\omega)((\alpha+5)c\gamma/2 - j\omega)}{((\alpha+1)c\gamma/2 + j\omega)((\alpha+3)c\gamma/2 + j\omega)((\alpha+5)c\gamma/2 + j\omega)} \times$$

$$\times \frac{((\alpha+7)c\gamma/2 - j\omega)}{((\alpha+7)c\gamma/2 + j\omega)} - 1;$$

$$W_5 \left\{ \frac{\partial P_5^{(\alpha,0)}(\tau, \gamma)}{\partial \tau} \right\} (j\omega) = \frac{j\omega}{((\alpha+11)c\gamma/2 + j\omega)} \times$$

$$\times \frac{((\alpha+1)c\gamma/2 - j\omega)((\alpha+3)c\gamma/2 - j\omega)((\alpha+5)c\gamma/2 - j\omega)}{((\alpha+1)c\gamma/2 + j\omega)((\alpha+3)c\gamma/2 + j\omega)((\alpha+5)c\gamma/2 + j\omega)} \times$$

$$\times \frac{((\alpha+7)c\gamma/2 - j\omega)((\alpha+9)c\gamma/2 - j\omega)}{((\alpha+7)c\gamma/2 + j\omega)((\alpha+9)c\gamma/2 + j\omega)} + 1.$$



Рис. 6.36. Вид преобразования Фурье производных ортогональных функций Якоби 2-ого порядка: а)  $\gamma = 0,25, c = 2, \alpha \in [0; 5], \beta = 0$ ; б)  $\gamma \in [0,25; 2], c = 2, \alpha = 1, \beta = 0$

$$[6.104] \quad W_k^{[1]}\left\{\frac{\partial P_k^{(0,1)}(\tau, \gamma)}{\partial \tau}\right\}(j\omega) = j\omega \sum_{s=0}^k \binom{k}{s} \times \\ \times \binom{k+s+1}{s} (-1)^s \frac{1}{(2s+1)\gamma + j\omega} - (-1)^k (k+1).$$

$$[6.105] \quad W_k^{[2]}\left\{\frac{\partial P_k^{(0,1)}(\tau, \gamma)}{\partial \tau}\right\}(j\omega) = \sum_{s=0}^k \binom{k}{s} \binom{k+s+1}{s} \times \\ \times (-1)^s j \sin \varphi_s \exp(-j\varphi_s) - (-1)^k (k+1), \\ \varphi_k = \arctan \frac{\omega}{(2k+1)\gamma}.$$

Частные случаи для преобразования Фурье производных функций 0-5 порядков:

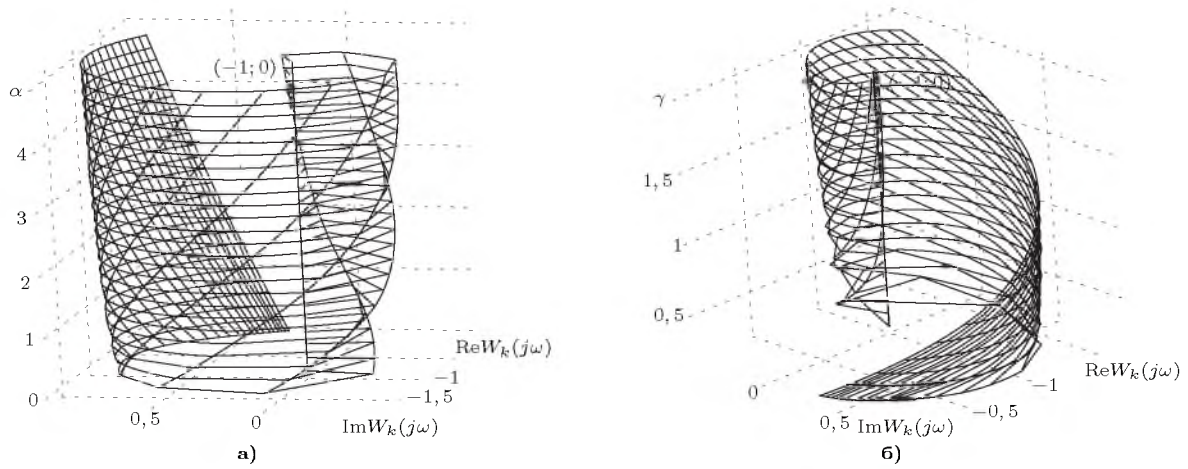
$$W_0\left\{\frac{\partial P_0^{(0,1)}(\tau, \gamma)}{\partial \tau}\right\}(j\omega) = -\frac{\gamma}{\gamma + j\omega};$$

$$W_1\left\{\frac{\partial P_1^{(0,1)}(\tau, \gamma)}{\partial \tau}\right\}(j\omega) = \frac{j\omega}{\gamma + j\omega} - \frac{3j\omega}{3\gamma + j\omega} + 2;$$

$$W_2\left\{\frac{\partial P_2^{(0,1)}(\tau, \gamma)}{\partial \tau}\right\}(j\omega) = \frac{j\omega}{\gamma + j\omega} - \frac{8j\omega}{3\gamma + j\omega} + \frac{10j\omega}{5\gamma + j\omega} - 3;$$

$$W_3\left\{\frac{\partial P_3^{(0,1)}(\tau, \gamma)}{\partial \tau}\right\}(j\omega) = \frac{j\omega}{\gamma + j\omega} - \frac{15j\omega}{3\gamma + j\omega} + \frac{45j\omega}{5\gamma + j\omega} - \frac{35j\omega}{7\gamma + j\omega} + 4;$$

$$W_4\left\{\frac{\partial P_4^{(0,1)}(\tau, \gamma)}{\partial \tau}\right\}(j\omega) = \frac{j\omega}{\gamma + j\omega} - \frac{24j\omega}{3\gamma + j\omega} + \frac{126j\omega}{5\gamma + j\omega} - \frac{224j\omega}{7\gamma + j\omega} + \frac{126j\omega}{9\gamma + j\omega} - 5;$$

$$W_5\left\{\frac{\partial P_5^{(0,1)}(\tau, \gamma)}{\partial \tau}\right\}(j\omega) = \frac{j\omega}{\gamma + j\omega} - \frac{35j\omega}{3\gamma + j\omega} + \frac{280j\omega}{5\gamma + j\omega} - \frac{840j\omega}{7\gamma + j\omega} + \frac{1050j\omega}{9\gamma + j\omega} - \frac{462j\omega}{11\gamma + j\omega} + 6.$$



Рис. 6.37. Вид преобразования Фурье производных ортогональных функций Якоби 0-5 порядков;  $\gamma = 0,25, c = 2, \alpha = 0, \beta = 1$

$$[6.106] \quad W_k^{[1]}\left\{\frac{\partial P_k^{(0,2)}(\tau, \gamma)}{\partial \tau}\right\}(j\omega) = j\omega \sum_{s=0}^k \binom{k}{s} \times \\ \times \binom{k+s+2}{s} (-1)^s \frac{1}{(2s+1)\gamma + j\omega} - (-1)^k \frac{(k+1)(k+2)}{2}.$$

$$[6.107] \quad W_k^{[2]}\left\{\frac{\partial P_k^{(0,2)}(\tau, \gamma)}{\partial \tau}\right\}(j\omega) = \sum_{s=0}^k \binom{k}{s} \binom{k+s+2}{s} \times \\ \times (-1)^s j \sin \varphi_s \exp(-j\varphi_s) - (-1)^k \frac{(k+1)(k+2)}{2}, \\ \varphi_k = \arctan \frac{\omega}{(2k+1)\gamma}.$$

Частные случаи для преобразования Фурье производных функций 0-5 порядков:

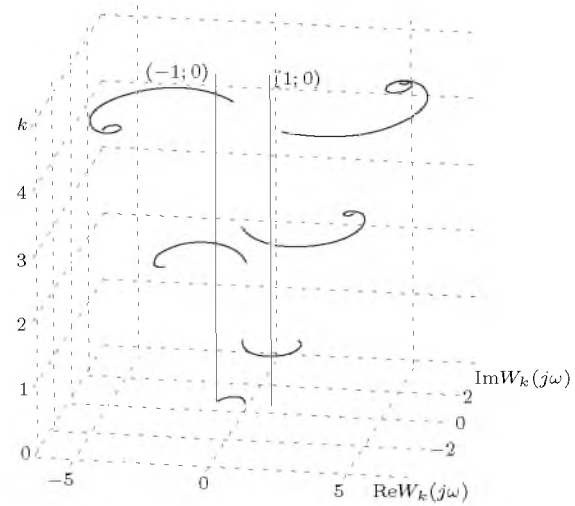
$$W_0^{\{P_0^{(0,2)}(\tau,\gamma)\}}(j\omega) = -\frac{\gamma}{\gamma + j\omega};$$

$$W_1^{\{P_1^{(0,2)}(\tau,\gamma)\}}(j\omega) = \frac{j\omega}{\gamma + j\omega} - \frac{4j\omega}{3\gamma + j\omega} + 3;$$

$$W_2^{\{P_2^{(0,2)}(\tau,\gamma)\}}(j\omega) = \frac{j\omega}{\gamma + j\omega} - \frac{10j\omega}{3\gamma + j\omega} + \frac{15j\omega}{5\gamma + j\omega} - 6;$$

$$W_3^{\{P_3^{(0,2)}(\tau,\gamma)\}}(j\omega) = \frac{j\omega}{\gamma + j\omega} - \frac{18j\omega}{3\gamma + j\omega} + \frac{63j\omega}{5\gamma + j\omega} - \frac{56j\omega}{7\gamma + j\omega} + 10;$$

$$W_4^{\{P_4^{(0,2)}(\tau,\gamma)\}}(j\omega) = \frac{j\omega}{\gamma + j\omega} - \frac{28j\omega}{3\gamma + j\omega} + \frac{168j\omega}{5\gamma + j\omega} - \frac{336j\omega}{7\gamma + j\omega} + \frac{210j\omega}{9\gamma + j\omega} - 15;$$

$$W_5^{\{P_5^{(0,2)}(\tau,\gamma)\}}(j\omega) = \frac{j\omega}{\gamma + j\omega} - \frac{40j\omega}{3\gamma + j\omega} + \frac{360j\omega}{5\gamma + j\omega} - \frac{1200j\omega}{7\gamma + j\omega} + \frac{1650j\omega}{9\gamma + j\omega} - \frac{792j\omega}{11\gamma + j\omega} + 21.$$



Рис. 6.38. Вид преобразования Фурье производных ортогональных функций Якоби 0-5 порядков;  $\gamma = 0, 25, c = 2, \alpha = 0, \beta = 2$

$$[6.108] \quad W_k^{[1]}\left\{\frac{\partial P_k^{(0,\beta)}(\tau,\gamma)}{\partial \tau}\right\}(j\omega) = j\omega \sum_{s=0}^k \binom{k}{s} \times \\ \times \binom{k+s+\beta}{s} (-1)^s \frac{1}{(2s+1)c\gamma/2 + j\omega} - (-1)^k \binom{k+\beta}{k}.$$

$$[6.109] \quad W_k^{[2]}\left\{\frac{\partial P_k^{(0,\beta)}(\tau,\gamma)}{\partial \tau}\right\}(j\omega) = \sum_{s=0}^k \binom{k}{s} \binom{k+s+\beta}{s} \times \\ \times (-1)^s j \sin \varphi_s \exp(-j\varphi_s) - (-1)^k \binom{k+\beta}{k}, \\ \varphi_k = \arctan \frac{2\omega}{(2k+1)c\gamma}.$$

Частные случаи для преобразования Фурье функций 0-5 порядков:

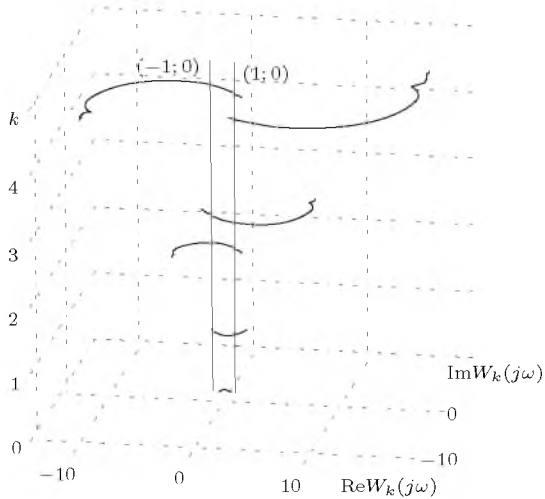
$$W_0^{\{P_0^{(0,\beta)}(\tau,\gamma)\}}(j\omega) = -\frac{c\gamma/2}{c\gamma/2 + j\omega};$$

$$W_1^{\{P_1^{(0,\beta)}(\tau,\gamma)\}}(j\omega) = \frac{j\omega}{c\gamma/2 + j\omega} - \frac{j\omega(\beta+2)}{3c\gamma/2 + j\omega} + \beta + 1;$$

$$W_2^{\{P_2^{(0,\beta)}(\tau,\gamma)\}}(j\omega) = \frac{j\omega}{c\gamma/2 + j\omega} - \frac{2j\omega(\beta+3)}{3c\gamma/2 + j\omega} + \\ + \frac{j\omega(\beta+3)(\beta+4)/2}{5c\gamma/2 + j\omega} - (\beta+1)(\beta+2)/2;$$

$$W_3^{\{P_3^{(0,\beta)}(\tau,\gamma)\}}(j\omega) = \frac{j\omega}{c\gamma/2 + j\omega} - \frac{3j\omega(\beta+4)}{3c\gamma/2 + j\omega} + \\ + \frac{3j\omega(\beta+4)(\beta+5)/2}{5c\gamma/2 + j\omega} - \frac{j\omega(\beta+4)(\beta+5)(\beta+6)/6}{7c\gamma/2 + j\omega} + (\beta+1) \times \\ \times (\beta+2)(\beta+3)/6;$$

$$W_4^{\{P_4^{(0,\beta)}(\tau,\gamma)\}}(j\omega) = \frac{j\omega}{c\gamma/2 + j\omega} - \frac{4j\omega(\beta+5)}{3c\gamma/2 + j\omega} + \\ + \frac{3j\omega(\beta+5)(\beta+6)}{5c\gamma/2 + j\omega} - \frac{2j\omega(\beta+5)(\beta+6)(\beta+7)/3}{7c\gamma/2 + j\omega} + \\ + \frac{j\omega(\beta+8)!}{24(\beta+4)!(9c\gamma/2 + j\omega)} - (\beta+1)(\beta+2)(\beta+3)(\beta+4)/24;$$

$$W_5^{\{P_5^{(0,\beta)}(\tau,\gamma)\}}(j\omega) = \frac{j\omega}{c\gamma/2 + j\omega} - \frac{5j\omega(\beta+6)}{3c\gamma/2 + j\omega} + \\ + \frac{5j\omega(\beta+6)(\beta+7)}{5c\gamma/2 + j\omega} - \frac{5j\omega(\beta+6)(\beta+7)(\beta+8)/3}{7c\gamma/2 + j\omega} + \\ + \frac{5j\omega(\beta+9)!}{24(\beta+5)!(9c\gamma/2 + j\omega)} - \frac{120(\beta+5)!(11c\gamma/2 + j\omega)}{120(\beta+5)!(11c\gamma/2 + j\omega)} + (\beta+1) \times \\ \times (\beta+2)(\beta+3)(\beta+4)(\beta+5)/120.$$



Рис. 6.39. Вид преобразования Фурье ортогональных функций Якоби 2-ого порядка: а)  $\gamma = 0,25, c = 2, \alpha = 0, \beta \in [0; 5];$  б)  $\gamma \in [0,25; 2], c = 2, \alpha = 0, \beta = 1$

### 6.4 Производные преобразований Фурье ортогональных функций

$$[6.110] \quad \frac{\partial W_k^{[1]\{L_k(\tau, \gamma)\}}(j\omega)}{\partial \omega} = -\frac{j}{(j\omega + \gamma/2)^2} \sum_{s=0}^k \binom{k}{k-s} \left(\frac{-\gamma}{j\omega + \gamma/2}\right)^s (s+1).$$

$$[6.111] \quad \frac{\partial W_k^{[2]\{L_k(\tau, \gamma)\}}(j\omega)}{\partial \omega} = -\frac{j(j\omega - \gamma(2k+1)/2)}{(j\omega + \gamma/2)^3} \left(\frac{j\omega - \gamma/2}{j\omega + \gamma/2}\right)^{k-1}.$$

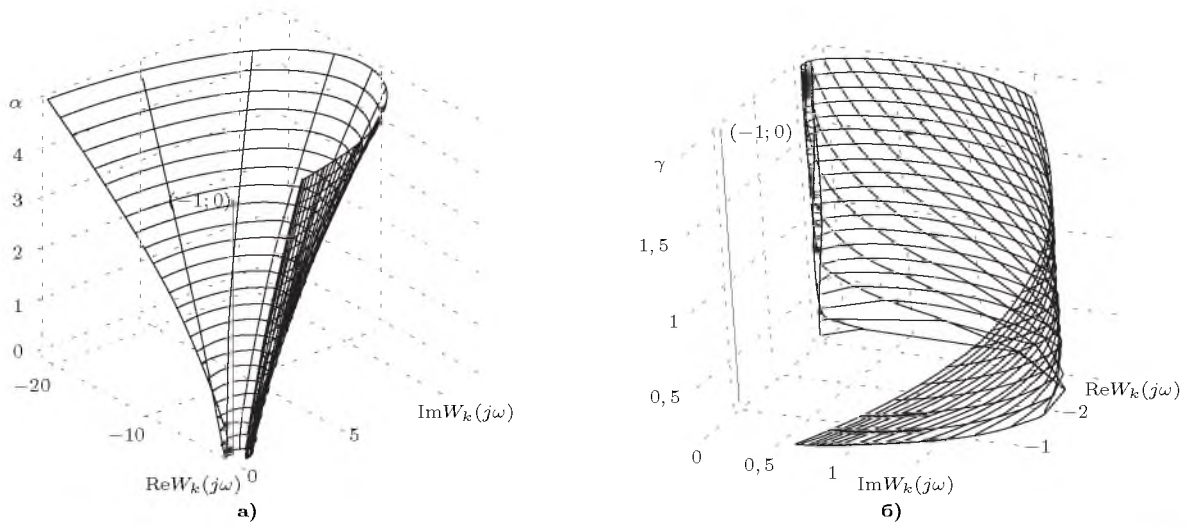
$$[6.112] \quad \frac{\partial W_k^{[3]\{L_k(\tau, \gamma)\}}(j\omega)}{\partial \omega} = -\frac{4j}{\gamma^2} (-1)^k (\cos \varphi)^2 \times \exp(-j(2k+1)\varphi) ((2k+1) \cos \varphi - j \sin \varphi),$$

$$\varphi = \arctan \frac{2\omega}{\gamma}.$$

Частные случаи для производных преобразования Фурье функций 0-5 порядков:

$$\frac{\partial W_0^{[L_0(\tau, \gamma)]}(j\omega)}{\partial \omega} = \frac{\omega + j\gamma/2}{(j\omega - \gamma/2)(j\omega + \gamma/2)^2};$$

$$\frac{\partial W_1^{[L_1(\tau, \gamma)]}(j\omega)}{\partial \omega} = \frac{\omega + 3j\gamma/2}{(j\omega + \gamma/2)^3};$$

$$\frac{\partial W_2^{[L_2(\tau, \gamma)]}(j\omega)}{\partial \omega} = \frac{(\omega + 5j\gamma/2)(j\omega - \gamma/2)}{(j\omega + \gamma/2)^4};$$

$$\frac{\partial W_3^{[L_3(\tau, \gamma)]}(j\omega)}{\partial \omega} = \frac{(\omega + 7j\gamma/2)(j\omega - \gamma/2)^2}{(j\omega + \gamma/2)^5};$$

$$\frac{\partial W_4^{[L_4(\tau, \gamma)]}(j\omega)}{\partial \omega} = \frac{(\omega + 9j\gamma/2)(j\omega - \gamma/2)^3}{(j\omega + \gamma/2)^6};$$

$$\frac{\partial W_5^{[L_5(\tau, \gamma)]}(j\omega)}{\partial \omega} = \frac{(\omega + 11j\gamma/2)(j\omega - \gamma/2)^4}{(j\omega + \gamma/2)^7}.$$



Рис. 6.40. Вид производных преобразования Фурье ортогональных функций Лагерра 0-5 порядков;  $\gamma = 4$

$$[6.113] \quad \frac{\partial W_k^{[1]\{L_k^{(1)}(\tau, \gamma)\}}(j\omega)}{\partial \omega} = \frac{1}{(j\omega + \gamma/2)^2} \sum_{s=0}^k \binom{k+1}{k-s} \left(\frac{-\gamma}{j\omega + \gamma/2}\right)^s.$$

$$[6.114] \quad \frac{\partial W_k^{[2]\{L_k^{(1)}(\tau, \gamma)\}}(j\omega)}{\partial \omega} = -\frac{j(k+1)(j\omega - \gamma/2)}{(j\omega + \gamma/2)^3} \left(\frac{j\omega - \gamma/2}{j\omega + \gamma/2}\right)^{k-1}.$$

Частные случаи для производных преобразования Фурье функций 0-5 порядков:

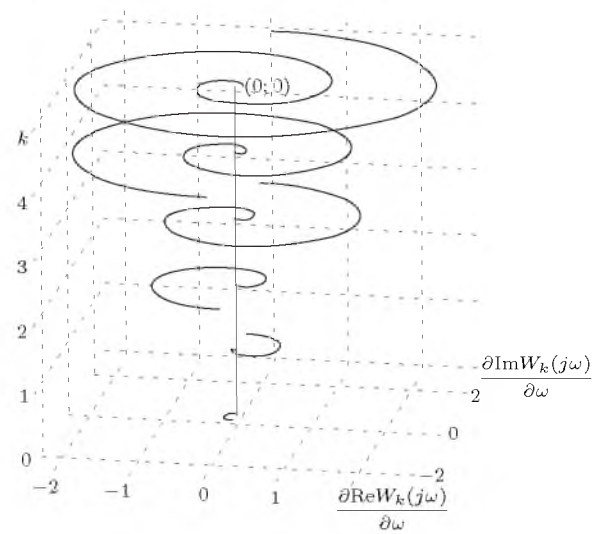
$$\begin{aligned} \frac{\partial W_0^{(L_0^{(1)}(\tau, \gamma))}(j\omega)}{\partial \omega} &= -\frac{j}{(j\omega + \gamma/2)^2}; \\ \frac{\partial W_1^{(L_1^{(1)}(\tau, \gamma))}(j\omega)}{\partial \omega} &= -\frac{2j(j\omega - \gamma/2)}{(j\omega + \gamma/2)^3}; \\ \frac{\partial W_2^{(L_2^{(1)}(\tau, \gamma))}(j\omega)}{\partial \omega} &= -\frac{3j(j\omega - \gamma/2)^2}{(j\omega + \gamma/2)^4}; \\ \frac{\partial W_3^{(L_3^{(1)}(\tau, \gamma))}(j\omega)}{\partial \omega} &= -\frac{4j(j\omega - \gamma/2)^3}{(j\omega + \gamma/2)^5}; \\ \frac{\partial W_4^{(L_4^{(1)}(\tau, \gamma))}(j\omega)}{\partial \omega} &= -\frac{5j(j\omega - \gamma/2)^4}{(j\omega + \gamma/2)^6}; \\ \frac{\partial W_5^{(L_5^{(1)}(\tau, \gamma))}(j\omega)}{\partial \omega} &= -\frac{6j(j\omega - \gamma/2)^5}{(j\omega + \gamma/2)^7}. \end{aligned}$$



Рис. 6.41. Вид производных преобразования Фурье ортогональных функций Сонина-Лагерра 0-5 порядков;  $\gamma = 4, \alpha = 1$

$$[6.115] \quad \frac{\partial W_k^{(L_k^{(2)}(\tau, \gamma))}(j\omega)}{\partial \omega} = \frac{1}{(j\omega + \gamma/2)^2} \sum_{s=0}^k (k+2) \binom{k+\alpha}{k-s} \left(\frac{-\gamma}{j\omega + \gamma/2}\right)^s.$$

Частные случаи для производных преобразования Фурье функций 0-5 порядков:

$$\frac{\partial W_0^{(L_0^{(2)}(\tau, \gamma))}(j\omega)}{\partial \omega} = -\frac{j}{(j\omega + \gamma/2)^2};$$

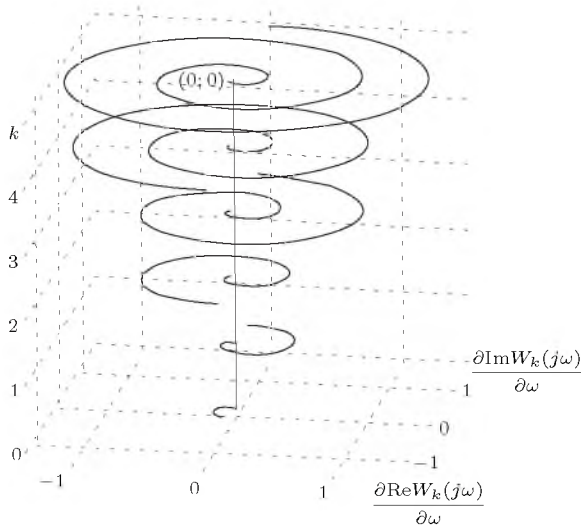
$$\begin{aligned} \frac{\partial W_1^{(L_1^{(2)}(\tau, \gamma))}(j\omega)}{\partial \omega} &= -\frac{j(3j\omega - \gamma/2)}{(j\omega + \gamma/2)^3}; \\ \frac{\partial W_2^{(L_2^{(2)}(\tau, \gamma))}(j\omega)}{\partial \omega} &= -\frac{2j(j\omega\gamma - \gamma^2/4 + 3\omega^2)}{(j\omega + \gamma/2)^4}; \\ \frac{\partial W_3^{(L_3^{(2)}(\tau, \gamma))}(j\omega)}{\partial \omega} &= \frac{2j}{(j\omega + \gamma/2)^6} (\gamma^3/8 - 10j\gamma^2\omega/8 - 20\gamma\omega^2/8 + 5j\omega^3); \\ \frac{\partial W_4^{(L_4^{(2)}(\tau, \gamma))}(j\omega)}{\partial \omega} &= -\frac{j}{(j\omega + \gamma/2)^6} (\gamma^4/16 - 6j\gamma^3\omega/4 - 20\gamma^2 \times \\ &\times \omega^2 + 10j\gamma\omega^3 + 240\omega^4); \\ \frac{\partial W_5^{(L_5^{(2)}(\tau, \gamma))}(j\omega)}{\partial \omega} &= \frac{j}{(j\omega + \gamma/2)^7} (\gamma^5/32 - 21j\gamma^4\omega/4 - 21\gamma^3 \times \\ &\times \omega^2/4 + 35j\gamma^2\omega^3/2 + 35\gamma\omega^4/2 - 672j\omega^5). \end{aligned}$$



Рис. 6.42. Вид производных преобразования Фурье ортогональных функций Сонина-Лагерра 0-5 порядков;  $\gamma = 4, \alpha = 2$

$$[6.116] \quad \frac{\partial W_k^{(L_k^{(\alpha)}(\tau, \gamma))}(j\omega)}{\partial \omega} = \frac{1}{(j\omega + \gamma/2)^2} \sum_{s=0}^k \binom{k+\alpha}{k-s} \left(\frac{-\gamma}{j\omega + \gamma/2}\right)^s.$$

Частные случаи для производных преобразования Фурье функций 0-5 порядков:

$$\begin{aligned} \frac{\partial W_0^{(L_0^{(\alpha)}(\tau, \gamma))}(j\omega)}{\partial \omega} &= -\frac{j}{(j\omega + \gamma/2)^2}; \\ \frac{\partial W_1^{(L_1^{(\alpha)}(\tau, \gamma))}(j\omega)}{\partial \omega} &= -\frac{j(\alpha+1)}{(j\omega + \gamma/2)^2} + \frac{2j\gamma}{(j\omega + \gamma/2)^3}; \\ \frac{\partial W_2^{(L_2^{(\alpha)}(\tau, \gamma))}(j\omega)}{\partial \omega} &= -\frac{j(\alpha+1)(\alpha+2)}{2(j\omega + \gamma/2)^2} + \frac{2j\gamma(\alpha+2)}{(j\omega + \gamma/2)^3} - \\ &- \frac{3j\gamma^2}{(j\omega + \gamma/2)^4}; \end{aligned}$$

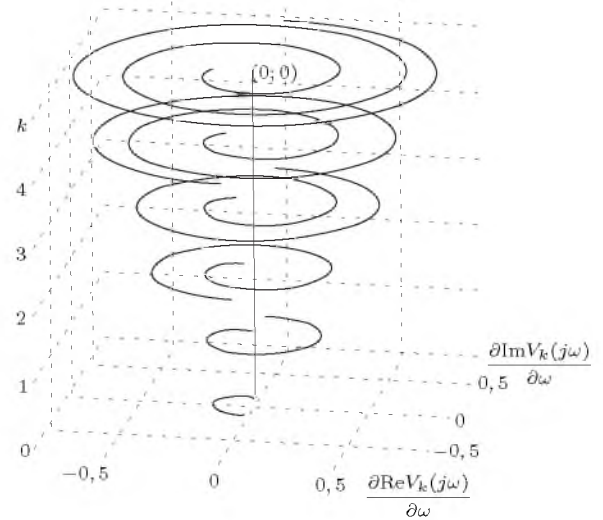
$$\begin{aligned} \frac{\partial W_3^{\{L_3^{(\alpha)}(\tau, \gamma)\}}(j\omega)}{\partial \omega} &= -\frac{j(\alpha+3)!}{6\alpha!(j\omega+\gamma/2)^2} + \frac{j\gamma(\alpha+2)(\alpha+3)}{(j\omega+\gamma/2)^3} - \\ &- \frac{3j\gamma^2(\alpha+3)}{(j\omega+\gamma/2)^4} + \frac{4j\gamma^3}{(j\omega+\gamma/2)^5}; \\ \frac{\partial W_4^{\{L_4^{(\alpha)}(\tau, \gamma)\}}(j\omega)}{\partial \omega} &= -\frac{j(\alpha+4)!}{24\alpha!(j\omega+\gamma/2)^2} + \frac{j\gamma(\alpha+4)!}{3(\alpha+1)!} \times \\ &\times \frac{1}{(j\omega+\gamma/2)^3} - \frac{3j\gamma^2(\alpha+3)(\alpha+4)}{2(j\omega+\gamma/2)^4} + \frac{4j\gamma^3(\alpha+4)}{(j\omega+\gamma/2)^5} - \frac{5j\gamma^4}{(j\omega+\gamma/2)^6}; \\ \frac{\partial W_5^{\{L_5^{(\alpha)}(\tau, \gamma)\}}(j\omega)}{\partial \omega} &= -\frac{j(\alpha+5)!}{120\alpha!(j\omega+\gamma/2)^2} + \frac{j\gamma(\alpha+5)!}{12(\alpha+1)!} \times \\ &\times \frac{1}{(j\omega+\gamma/2)^3} - \frac{j\gamma^2(\alpha+5)!}{2(\alpha+2)!(j\omega+\gamma/2)^4} + \frac{2j\gamma^3(\alpha+4)(\alpha+5)}{(j\omega+\gamma/2)^5} - \\ &- \frac{5j\gamma^4(\alpha+5)}{(j\omega+\gamma/2)^6} + \frac{6j\gamma^5}{(j\omega+\gamma/2)^7}. \end{aligned}$$



Рис. 6.43. Вид производных преобразования Фурье ортогональных функций Сонина-Лагерра 2-ого порядка: а)  $\gamma = 4, \alpha \in [0; 5]$ ; б)  $\gamma \in [2; 4], \alpha = 1$

$$[6.117] \quad \frac{\partial W_k^{\{P_k^{(-1/2,0)}(\tau, \gamma)\}}(j\omega)}{\partial \omega} = -j \sum_{s=0}^k \binom{k}{s} \binom{k+s-1/2}{s-1/2} (-1)^s \frac{1}{((4s+1)\gamma/2 + j\omega)^2}.$$

$$[6.118] \quad \frac{\partial W_k^{\{P_k^{(-1/2,0)}(\tau, \gamma)\}}(j\omega)}{\partial \omega} = \begin{cases} -\frac{j}{(\gamma/2 + j\omega)^2}, & \text{если } k = 0; \\ -\frac{j}{(4k+1)\gamma/2 + j\omega} \times \\ \times \prod_{s=0}^{k-1} \frac{(4s+1)\gamma/2 - j\omega}{(4s+1)\gamma/2 + j\omega} \times \\ \times \left( \frac{1}{(4k+1)\gamma/2 + j\omega} + \right. \\ \left. + \gamma \sum_{s=0}^{k-1} \frac{4s+1}{((4s+1)\gamma/2)^2 + \omega^2} \right), & \text{если } k > 0. \end{cases}$$

$$[6.119] \quad \frac{\partial W_k^{\{P_k^{(-1/2,0)}(\tau, \gamma)\}}(j\omega)}{\partial \omega} = \begin{cases} -\frac{4j(\cos \varphi_0)^2}{\gamma^2} \exp(-2j\varphi_0), & \text{если } k = 0; \\ -\frac{2j \cos \varphi_k}{(4k+1)\gamma} \times \\ \times \exp\left(-j\left(\varphi_k + 2 \sum_{s=0}^{k-1} \varphi_s\right)\right) \times \\ \times \left( \frac{2 \cos \varphi_k \exp(-j\varphi_k)}{(4k+1)\gamma} + \right. \\ \left. + \frac{4}{\gamma} \sum_{s=0}^{k-1} \frac{(\cos \varphi_k)^2}{4s+1} \right), & \text{если } k > 0, \end{cases}$$

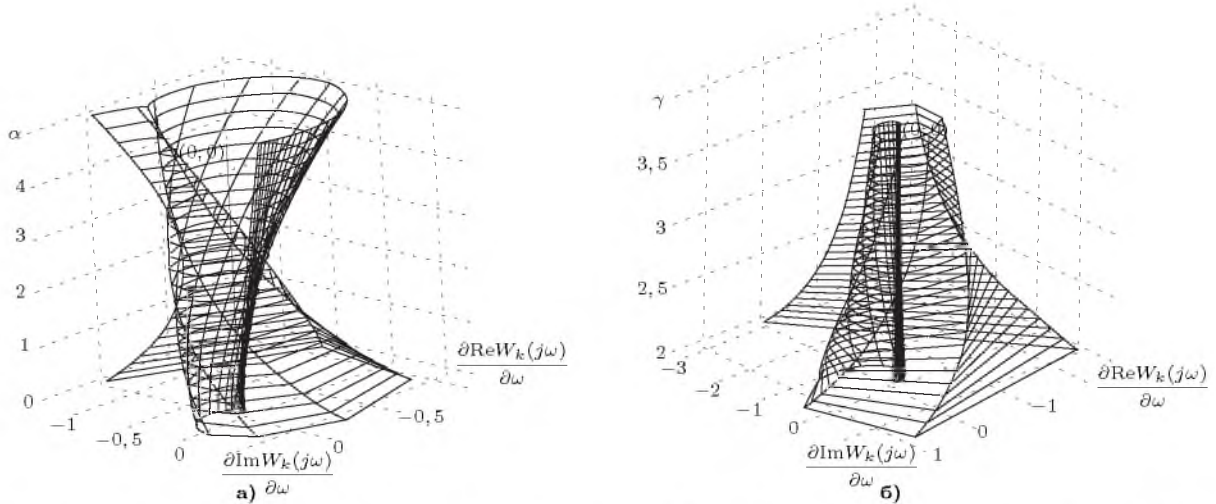
$$\varphi_k = \arctan \frac{2\omega}{(4k+1)\gamma}.$$

Частные случаи для производных преобразования Фурье функций 0-5 порядков:

$$\begin{aligned} \frac{\partial W_0^{\{P_0^{(-1/2,0)}(\tau, \gamma)\}}(j\omega)}{\partial \omega} &= -\frac{j}{(\gamma/2 + j\omega)^2}; \\ \frac{\partial W_1^{\{P_1^{(-1/2,0)}(\tau, \gamma)\}}(j\omega)}{\partial \omega} &= -\frac{j}{2(\gamma/2 + j\omega)^2} + \frac{3j}{2(5\gamma/2 + j\omega)^2}; \\ \frac{\partial W_2^{\{P_2^{(-1/2,0)}(\tau, \gamma)\}}(j\omega)}{\partial \omega} &= -\frac{3j}{8(\gamma/2 + j\omega)^2} + \frac{15j}{4(5\gamma/2 + j\omega)^2} - \end{aligned}$$



$$\begin{aligned} \frac{\partial W_3^{\{P_3^{(-1/2,0)}(\tau,\gamma)\}}(j\omega)}{\partial \omega} &= -\frac{35j}{8(9\gamma/2 + j\omega)^2}; \\ \frac{\partial W_4^{\{P_4^{(-1/2,0)}(\tau,\gamma)\}}(j\omega)}{\partial \omega} &= -\frac{5j}{16(\gamma/2 + j\omega)^2} + \frac{105j}{16(5\gamma/2 + j\omega)^2} - \\ &= -\frac{315j}{16(9\gamma/2 + j\omega)^2} + \frac{231j}{16(13\gamma/2 + j\omega)^2}; \\ \frac{\partial W_5^{\{P_5^{(-1/2,0)}(\tau,\gamma)\}}(j\omega)}{\partial \omega} &= -\frac{35j}{128(\gamma/2 + j\omega)^2} + \frac{315j}{32} \times \\ &\times \frac{1}{(5\gamma/2 + j\omega)^2} - \frac{3465j}{64(9\gamma/2 + j\omega)^2} + \frac{3003j}{32(13\gamma/2 + j\omega)^2} - \\ &= -\frac{128(17\gamma/2 + j\omega)^2}{109395j} + \frac{63j}{256(\gamma/2 + j\omega)^2} + \frac{3465j}{256} \times \\ &\times \frac{1}{(5\gamma/2 + j\omega)^2} - \frac{15015j}{128(9\gamma/2 + j\omega)^2} + \frac{45045j}{128(13\gamma/2 + j\omega)^2} - \\ &= -\frac{128(17\gamma/2 + j\omega)^2}{256(17\gamma/2 + j\omega)^2} + \frac{15015j}{256(21\gamma/2 + j\omega)^2}. \end{aligned}$$



Рис. 6.44. Вид производных преобразования Фурье ортогональных функций Якоби 0-5 порядков;  $\gamma = 1, c = 2, \alpha = -1/2, \beta = 0$

$$\begin{aligned} [6.120] \quad \frac{\partial W_k^{\{Legk(\tau,\gamma)\}}(j\omega)}{\partial \omega} &= \\ &= -j \sum_{s=0}^k \binom{k}{s} \binom{k+s}{s} (-1)^s \frac{1}{((2s+1)\gamma + j\omega)^2}. \end{aligned}$$

$$\begin{aligned} [6.121] \quad \frac{\partial W_k^{\{Legk(\tau,\gamma)\}}(j\omega)}{\partial \omega} &= \\ &= \begin{cases} -\frac{j}{(\gamma + j\omega)^2}, & \text{если } k = 0; \\ \left[ -\frac{j}{(\gamma + j\omega)^2} \times \right. \\ \left. \times \prod_{s=0}^{k-1} \frac{(2s+1)\gamma - j\omega}{(2s+1)\gamma + j\omega} \times \right. \\ \left. \times \left( \frac{1}{(2k+1)\gamma + j\omega} + \right. \right. \\ \left. \left. + 2\gamma \sum_{s=0}^{k-1} \frac{2s+1}{((2s+1)\gamma)^2 + \omega^2} \right) \right], & \text{если } k > 0, \end{cases} \end{aligned}$$

$$\begin{aligned} [6.122] \quad \frac{\partial W_k^{\{Legk(\tau,\gamma)\}}(j\omega)}{\partial \omega} &= \\ &= \begin{cases} -\frac{j(\cos \varphi_0)^2}{\gamma^2} \exp(-2j\varphi_0), & \text{если } k = 0; \\ -\frac{j \cos \varphi_k}{(2k+1)\gamma} \times \\ \times \exp\left(-j\left(\varphi_k + 2 \sum_{s=0}^{k-1} \varphi_s\right)\right) \times \\ \times \left( \frac{\cos \varphi_k \exp(-j\varphi_k)}{(2k+1)\gamma} + \right. \\ \left. + \frac{2}{\gamma} \sum_{s=0}^{k-1} \frac{(\cos \varphi_k)^2}{2s+1} \right), & \text{если } k > 0, \end{cases} \\ \varphi_k &= \arctan \frac{\omega}{(2k+1)\gamma}. \end{aligned}$$

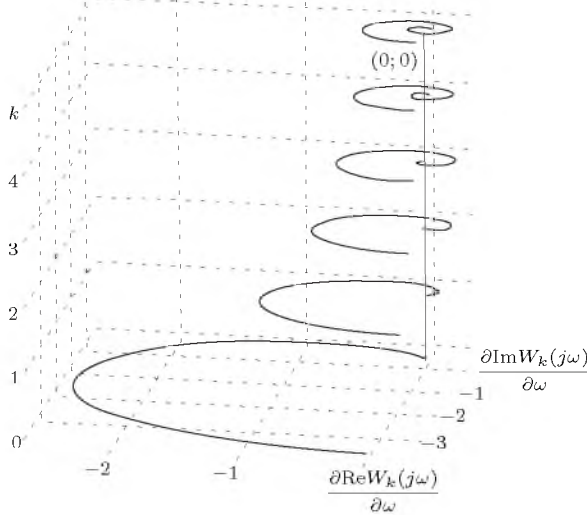
Частные случаи для производных преобразования Фурье функций 0-5 порядков:

$$\begin{aligned} \frac{\partial W_0^{\{Leg_0(\tau,\gamma)\}}(j\omega)}{\partial \omega} &= -\frac{j}{(\gamma + j\omega)^2}; \\ \frac{\partial W_1^{\{Leg_1(\tau,\gamma)\}}(j\omega)}{\partial \omega} &= -\frac{j}{(\gamma + j\omega)^2} + \frac{2j}{(3\gamma + j\omega)^2}; \\ \frac{\partial W_2^{\{Leg_2(\tau,\gamma)\}}(j\omega)}{\partial \omega} &= -\frac{j}{(\gamma + j\omega)^2} + \frac{6j}{(3\gamma + j\omega)^2} - \frac{6j}{(5\gamma + j\omega)^2}; \\ \frac{\partial W_3^{\{Leg_3(\tau,\gamma)\}}(j\omega)}{\partial \omega} &= -\frac{j}{(\gamma + j\omega)^2} + \frac{12j}{(3\gamma + j\omega)^2} - \\ &= -\frac{30j}{(5\gamma + j\omega)^2} + \frac{20j}{(7\gamma + j\omega)^2}; \\ \frac{\partial W_4^{\{Leg_4(\tau,\gamma)\}}(j\omega)}{\partial \omega} &= -\frac{j}{(\gamma + j\omega)^2} + \frac{20j}{(3\gamma + j\omega)^2} - \\ &= -\frac{90j}{(5\gamma + j\omega)^2} + \frac{140j}{(7\gamma + j\omega)^2} - \frac{70j}{(9\gamma + j\omega)^2}; \\ \frac{\partial W_5^{\{Leg_5(\tau,\gamma)\}}(j\omega)}{\partial \omega} &= -\frac{j}{(\gamma + j\omega)^2} + \frac{30j}{(3\gamma + j\omega)^2} - \\ &= -\frac{210j}{(5\gamma + j\omega)^2} + \frac{560j}{(7\gamma + j\omega)^2} - \frac{630j}{(9\gamma + j\omega)^2} + \frac{252j}{(11\gamma + j\omega)^2}. \end{aligned}$$



Рис. 6.45. Вид производных преобразования Фурье ортогональных функций Лежандра 0-5 порядков;  $\gamma = 1, c = 2$

$$[6.123] \quad \frac{\partial W_k^{[1]\{P_k^{(1/2,0)}(\tau,\gamma)\}}(j\omega)}{\partial \omega} = -j \sum_{s=0}^k \binom{k}{s} \binom{k+s+1/2}{s+1/2} (-1)^s \frac{1}{((4s+3)\gamma/2 + j\omega)^2}$$

$$[6.124] \quad \frac{\partial W_k^{[2]\{P_k^{(1/2,0)}(\tau,\gamma)\}}(j\omega)}{\partial \omega} = \begin{cases} -\frac{j}{(3\gamma/2 + j\omega)^2}, & \text{если } k = 0; \\ -\frac{j}{(4k+3)\gamma/2 + j\omega} \times \prod_{s=0}^{k-1} \frac{(4s+3)\gamma/2 - j\omega}{(4s+3)\gamma/2 + j\omega} \times \left( \frac{1}{(4k+3)\gamma/2 + j\omega} + \gamma \sum_{s=0}^{k-1} \frac{4s+3}{((4s+3)\gamma/2)^2 + \omega^2} \right), & \text{если } k > 0. \end{cases}$$

$$[6.125] \quad \frac{\partial W_k^{[3]\{P_k^{(1/2,0)}(\tau,\gamma)\}}(j\omega)}{\partial \omega} = \begin{cases} -\frac{4j(\cos \varphi_0)^2 \exp(-2j\varphi_0)}{(4k+3)\gamma} \times \exp\left(-j\left(\varphi_k + 2\sum_{s=0}^{k-1} \varphi_s\right)\right) \times \left( \frac{2\cos \varphi_k \exp(-j\varphi_k)}{(4k+3)\gamma} + \frac{4}{\gamma} \sum_{s=0}^{k-1} \frac{(\cos \varphi_k)^2}{4s+3} \right), & \text{если } k = 0; \\ \text{если } k > 0, \end{cases}$$

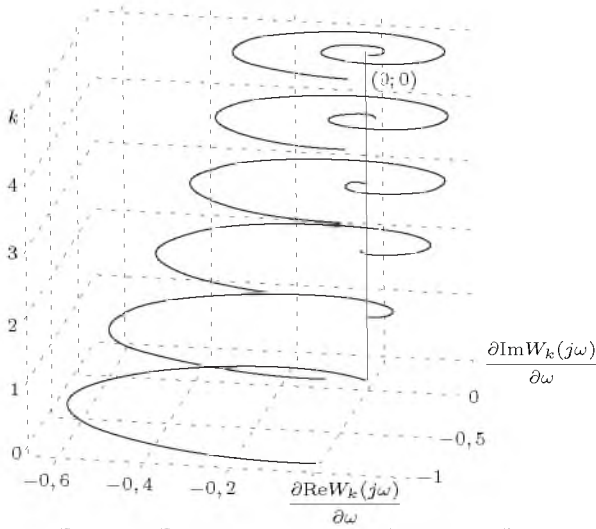
$$\varphi_k = \arctan \frac{2\omega}{(4k+3)\gamma}$$

Частные случаи для производных преобразования Фурье функций 0-5 порядков:

$$\begin{aligned} \frac{\partial W_0^{[P_0^{(1/2,0)}(\tau,\gamma)]}(j\omega)}{\partial \omega} &= -\frac{j}{(3\gamma/2 + j\omega)^2}; \\ \frac{\partial W_1^{[P_1^{(1/2,0)}(\tau,\gamma)]}(j\omega)}{\partial \omega} &= -\frac{3j}{2(3\gamma/2 + j\omega)^2} + \frac{5j}{2(7\gamma/2 + j\omega)^2}; \\ \frac{\partial W_2^{[P_2^{(1/2,0)}(\tau,\gamma)]}(j\omega)}{\partial \omega} &= -\frac{15j}{8(3\gamma/2 + j\omega)^2} + \frac{35j}{4(7\gamma/2 + j\omega)^2} - \frac{63j}{8(11\gamma/2 + j\omega)^2}; \\ \frac{\partial W_3^{[P_3^{(1/2,0)}(\tau,\gamma)]}(j\omega)}{\partial \omega} &= -\frac{35j}{16(3\gamma/2 + j\omega)^2} + \frac{315j}{16(7\gamma/2 + j\omega)^2} - \frac{693j}{16(11\gamma/2 + j\omega)^2} + \frac{429j}{16(15\gamma/2 + j\omega)^2}; \\ \frac{\partial W_4^{[P_4^{(1/2,0)}(\tau,\gamma)]}(j\omega)}{\partial \omega} &= -\frac{315j}{128(3\gamma/2 + j\omega)^2} + \frac{1155j}{32} \times \left( \frac{1}{(7\gamma/2 + j\omega)^2} - \frac{9009j}{64(11\gamma/2 + j\omega)^2} + \frac{6435j}{32(15\gamma/2 + j\omega)^2} - \frac{128(19\gamma/2 + j\omega)^2}{12155j} \right); \\ \frac{\partial W_5^{[P_5^{(1/2,0)}(\tau,\gamma)]}(j\omega)}{\partial \omega} &= -\frac{693j}{256(3\gamma/2 + j\omega)^2} + \frac{15015j}{256} \times \left( \frac{1}{(7\gamma/2 + j\omega)^2} - \frac{45045j}{230945j} - \frac{128(11\gamma/2 + j\omega)^2}{88179j} + \frac{109395j}{128(15\gamma/2 + j\omega)^2} - \frac{128(19\gamma/2 + j\omega)^2}{256(23\gamma/2 + j\omega)^2} \right). \end{aligned}$$



Рис. 6.46. Вид производных преобразования Фурье ортогональных функций Якоби 0-5 порядков;  $\gamma = 1, c = 2, \alpha = 1/2, \beta = 0$

$$[6.126] \quad \frac{\partial W_k^{[1]\{P_k^{(1,0)}(\tau, \gamma)\}}(j\omega)}{\partial \omega} = -j \sum_{s=0}^k \binom{k}{s} \binom{k+s+1}{s+1} (-1)^s \frac{1}{((s+1)\gamma + j\omega)^2}.$$

$$[6.127] \quad \frac{\partial W_k^{[2]\{P_k^{(1,0)}(\tau, \gamma)\}}(j\omega)}{\partial \omega} = \begin{cases} -\frac{j}{(\gamma + j\omega)^2}, & \text{если } k = 0; \\ -\frac{(k+1)\gamma + j\omega}{j} \times \prod_{s=0}^{k-1} \frac{(s+1)\gamma - j\omega}{(s+1)\gamma + j\omega} \times \left( \frac{1}{(k+1)\gamma + j\omega} + 2\gamma \sum_{s=0}^{k-1} \frac{s+1}{((s+1)\gamma)^2 + \omega^2} \right), & \text{если } k > 0. \end{cases}$$

$$[6.128] \quad \frac{\partial W_k^{[3]\{P_k^{(1,0)}(\tau, \gamma)\}}(j\omega)}{\partial \omega} = \begin{cases} -\frac{j(\cos \varphi_0)^2}{\gamma^2} \exp(-2j\varphi_0), & \text{если } k = 0; \\ -\frac{j \cos \varphi_k}{(k+1)\gamma} \times \exp\left(-j\left(\varphi_k + 2 \sum_{s=0}^{k-1} \varphi_s\right)\right) \times \left( \frac{\cos \varphi_k \exp(-j\varphi_k)}{(k+1)\gamma} + \frac{2}{\gamma} \sum_{s=0}^{k-1} \frac{(\cos \varphi_k)^2}{s+1} \right), & \text{если } k > 0, \end{cases}$$

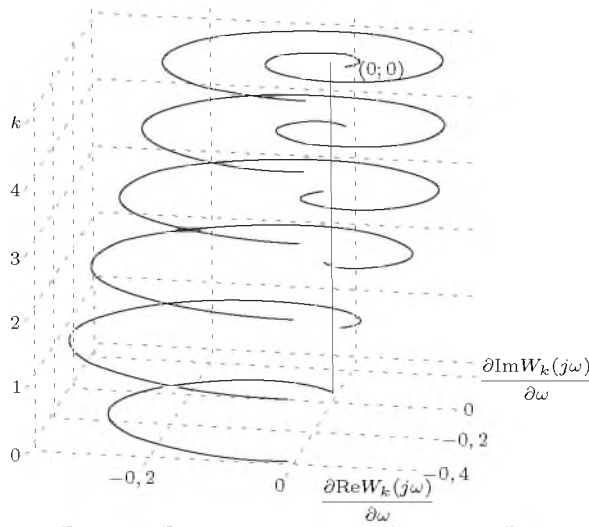
$$\varphi_k = \arctan \frac{\omega}{(k+1)\gamma}.$$

Частные случаи для производных преобразования Фурье функций 0-5 порядков:

$$\begin{aligned} \frac{\partial W_0^{[P_0^{(1,0)}(\tau, \gamma)]}(j\omega)}{\partial \omega} &= -\frac{j}{(\gamma + j\omega)^2}; \\ \frac{\partial W_1^{[P_1^{(1,0)}(\tau, \gamma)]}(j\omega)}{\partial \omega} &= -\frac{2j}{(\gamma + j\omega)^2} + \frac{3j}{(2\gamma + j\omega)^2}; \\ \frac{\partial W_2^{[P_2^{(1,0)}(\tau, \gamma)]}(j\omega)}{\partial \omega} &= -\frac{3j}{(\gamma + j\omega)^2} + \frac{12j}{(2\gamma + j\omega)^2} - \frac{10j}{(3\gamma + j\omega)^2}; \\ \frac{\partial W_3^{[P_3^{(1,0)}(\tau, \gamma)]}(j\omega)}{\partial \omega} &= -\frac{4j}{(\gamma + j\omega)^2} + \frac{30j}{(2\gamma + j\omega)^2} - \frac{60j}{(3\gamma + j\omega)^2} + \frac{35j}{(4\gamma + j\omega)^2}; \\ \frac{\partial W_4^{[P_4^{(1,0)}(\tau, \gamma)]}(j\omega)}{\partial \omega} &= -\frac{5j}{(\gamma + j\omega)^2} + \frac{60j}{(2\gamma + j\omega)^2} - \frac{210j}{(3\gamma + j\omega)^2} + \frac{280j}{(4\gamma + j\omega)^2} - \frac{126j}{(5\gamma + j\omega)^2}; \\ \frac{\partial W_5^{[P_5^{(1,0)}(\tau, \gamma)]}(j\omega)}{\partial \omega} &= -\frac{6j}{(\gamma + j\omega)^2} + \frac{105j}{(2\gamma + j\omega)^2} - \frac{560j}{(3\gamma + j\omega)^2} + \frac{1260j}{(4\gamma + j\omega)^2} - \frac{1260j}{(5\gamma + j\omega)^2} + \frac{462j}{(6\gamma + j\omega)^2}. \end{aligned}$$



Рис. 6.47. Вид производных преобразования Фурье ортогональных функций Якоби 0-5 порядков;  $\gamma = 1, c = 1, \alpha = 1, \beta = 0$

$$\begin{aligned}
 [6.129] \quad \frac{\partial W_k^{[1]\{P_k^{(2,0)}(\tau, \gamma)\}}(j\omega)}{\partial \omega} &= \\
 &= -j \sum_{s=0}^k \binom{k}{s} \binom{k+s+2}{s+2} (-1)^s \frac{1}{((2s+3)\gamma + j\omega)^2}.
 \end{aligned}$$

$$\begin{aligned}
 [6.130] \quad \frac{\partial W_k^{[2]\{P_k^{(2,0)}(\tau, \gamma)\}}(j\omega)}{\partial \omega} &= \\
 &= \begin{cases} -\frac{j}{(\gamma + j\omega)^2}, & \text{если } k = 0; \\ -\frac{(2k+3)\gamma + j\omega}{(2s+3)\gamma + j\omega} \times \\ \times \prod_{s=0}^{k-1} \frac{(2s+3)\gamma - j\omega}{(2s+3)\gamma + j\omega} \times \\ \times \left( \frac{1}{(2k+3)\gamma + j\omega} + \right. \\ \left. + 2\gamma \sum_{s=0}^{k-1} \frac{2s+3}{((2s+3)\gamma)^2 + \omega^2} \right), & \text{если } k > 0. \end{cases}
 \end{aligned}$$

$$\begin{aligned}
 [6.131] \quad \frac{\partial W_k^{[3]\{P_k^{(2,0)}(\tau, \gamma)\}}(j\omega)}{\partial \omega} &= \\
 &= \begin{cases} -\frac{j(\cos \varphi_0)^2}{\gamma^2} \exp(-2j\varphi_0), & \text{если } k = 0; \\ -\frac{j \cos \varphi_k}{(2k+3)\gamma} \times \\ \times \exp\left(-j\left(\varphi_k + 2 \sum_{s=0}^{k-1} \varphi_s\right)\right) \times \\ \times \left( \frac{\cos \varphi_k \exp(-j\varphi_k)}{(2k+3)\gamma} + \right. \\ \left. + \frac{2}{\gamma} \sum_{s=0}^{k-1} \frac{(\cos \varphi_k)^2}{2s+3} \right), & \text{если } k > 0, \end{cases} \\
 \varphi_k &= \arctan \frac{\omega}{(2k+3)\gamma}.
 \end{aligned}$$

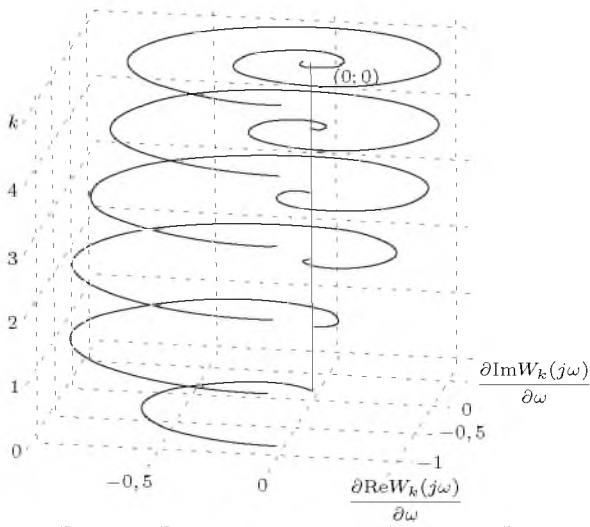
Частные случаи для производных преобразования Фурье функций 0-5 порядков:

$$\begin{aligned}
 \frac{\partial W_0^{(P_0^{(2,0)}(\tau, \gamma))}(j\omega)}{\partial \omega} &= -\frac{j}{(3\gamma + j\omega)^2}; \\
 \frac{\partial W_1^{(P_1^{(2,0)}(\tau, \gamma))}(j\omega)}{\partial \omega} &= -\frac{3j}{(3\gamma + j\omega)^2} + \frac{4j}{(5\gamma + j\omega)^2}; \\
 \frac{\partial W_2^{(P_2^{(2,0)}(\tau, \gamma))}(j\omega)}{\partial \omega} &= -\frac{6j}{(3\gamma + j\omega)^2} + \frac{20j}{(5\gamma + j\omega)^2} - \frac{15j}{(7\gamma + j\omega)^2}; \\
 \frac{\partial W_3^{(P_3^{(2,0)}(\tau, \gamma))}(j\omega)}{\partial \omega} &= -\frac{10j}{(3\gamma + j\omega)^2} + \frac{60j}{(5\gamma + j\omega)^2} - \\
 &- \frac{105j}{(7\gamma + j\omega)^2} + \frac{56j}{(9\gamma + j\omega)^2}; \\
 \frac{\partial W_4^{(P_4^{(2,0)}(\tau, \gamma))}(j\omega)}{\partial \omega} &= -\frac{15j}{(3\gamma + j\omega)^2} + \frac{140j}{(5\gamma + j\omega)^2} - \\
 &- \frac{420j}{(7\gamma + j\omega)^2} + \frac{504j}{(9\gamma + j\omega)^2} - \frac{210j}{(11\gamma + j\omega)^2}; \\
 \frac{\partial W_5^{(P_5^{(2,0)}(\tau, \gamma))}(j\omega)}{\partial \omega} &= -\frac{21j}{(3\gamma + j\omega)^2} + \frac{280j}{(5\gamma + j\omega)^2} - \\
 &- \frac{1260j}{(7\gamma + j\omega)^2} + \frac{2520j}{(9\gamma + j\omega)^2} - \frac{2310j}{(11\gamma + j\omega)^2} + \frac{792j}{(13\gamma + j\omega)^2}.
 \end{aligned}$$



Рис. 6.48. Вид производных преобразования Фурье ортогональных функций Якоби 0-5 порядков;  $\gamma = 1, c = 2, \alpha = 2, \beta = 0$

$$[6.132] \quad \frac{\partial W_k^{[1]\{P_k^{(\alpha,0)}(\tau,\gamma)\}}(j\omega)}{\partial \omega} = -j \sum_{s=0}^k \binom{k}{s} \times \times \binom{k+s+\alpha}{s+\alpha} (-1)^s \frac{1}{((2s+\alpha+1)c\gamma/2 + j\omega)^2}.$$

$$[6.133] \quad \frac{\partial W_k^{[2]\{P_k^{(\alpha,0)}(\tau,\gamma)\}}(j\omega)}{\partial \omega} = \begin{cases} -\frac{j}{((\alpha+1)c\gamma/2 + j\omega)^2}, & \text{если } k=0; \\ \frac{j}{(2k+\alpha+1)c\gamma/2 + j\omega} \times \prod_{s=0}^{k-1} \frac{(2s+\alpha+1)c\gamma/2 - j\omega}{(2s+\alpha+1)c\gamma/2 + j\omega} \times \left( \frac{1}{(2k+\alpha+1)c\gamma/2 + j\omega} + 2c\gamma/2 \times \sum_{s=0}^{k-1} \frac{2s+\alpha+1}{((2s+\alpha+1)c\gamma/2)^2 + \omega^2} \right), & \text{если } k > 0. \end{cases}$$

$$[6.134] \quad \frac{\partial W_k^{[3]\{P_k^{(\alpha,0)}(\tau,\gamma)\}}(j\omega)}{\partial \omega} = \begin{cases} -\frac{4j(\cos \varphi_0)^2}{(\alpha+1)^2 c^2 \gamma^2} \exp(-2j\varphi_0), & \text{если } k=0; \\ -\frac{2j \cos \varphi_k}{(2k+\alpha+1)c\gamma} \times \exp\left(-j\left(\varphi_k + 2 \sum_{s=0}^{k-1} \varphi_s\right)\right) \times \left( \frac{\cos \varphi_k \exp(-j\varphi_k)}{(2k+\alpha+1)c\gamma/2} + \frac{4}{c\gamma} \sum_{s=0}^{k-1} \frac{(\cos \varphi_k)^2}{2s+\alpha+1} \right), & \text{если } k > 0, \end{cases}$$

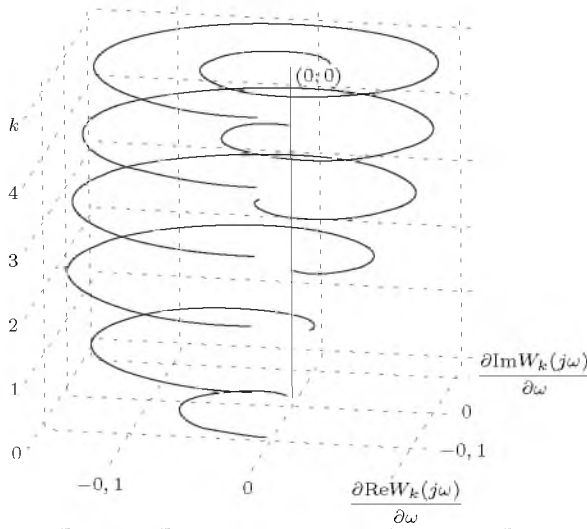
$$\varphi_k = \arctan \frac{2\omega}{(2k+\alpha+1)c\gamma}.$$

Частные случаи для производных преобразования Фурье функций 0-5 порядков:

$$\frac{\partial W_0^{[0]\{P_0^{(\alpha,0)}(\tau,\gamma)\}}(j\omega)}{\partial \omega} = -\frac{j}{(c\gamma(\alpha+1)/2 + j\omega)^2};$$

$$\frac{\partial W_1^{[1]\{P_1^{(\alpha,0)}(\tau,\gamma)\}}(j\omega)}{\partial \omega} = -\frac{j(\alpha+1)}{(c\gamma(\alpha+1)/2 + j\omega)^3} + j(\alpha+2) \times \frac{1}{(c\gamma(\alpha+3)/2 + j\omega)^2};$$

$$\frac{\partial W_2^{[2]\{P_2^{(\alpha,0)}(\tau,\gamma)\}}(j\omega)}{\partial \omega} = -\frac{j(\alpha+1)(\alpha+2)}{2(c\gamma(\alpha+1)/2 + j\omega)^2} + j(\alpha+2) \times \frac{(\alpha+3)}{2(c\gamma(\alpha+3)/2 + j\omega)^2} - \frac{j(\alpha+3)(\alpha+4)}{2(c\gamma(\alpha+5)/2 + j\omega)^2};$$

$$\frac{\partial W_3^{[3]\{P_3^{(\alpha,0)}(\tau,\gamma)\}}(j\omega)}{\partial \omega} = -\frac{j(\alpha+3)!}{6\alpha!(c\gamma(\alpha+1)/2 + j\omega)^2} + \frac{j(\alpha+4)!}{2(\alpha+1)!} \times \frac{1}{(c\gamma(\alpha+3)/2 + j\omega)^2} - \frac{j(\alpha+5)!}{2(\alpha+2)!(c\gamma(\alpha+5)/2 + j\omega)^2} + \frac{6(\alpha+3)!(c\gamma(\alpha+7)/2 + j\omega)^2}{j(\alpha+6)!};$$

$$\frac{\partial W_4^{[4]\{P_4^{(\alpha,0)}(\tau,\gamma)\}}(j\omega)}{\partial \omega} = -\frac{j(\alpha+4)!}{24\alpha!(c\gamma(\alpha+1)/2 + j\omega)^2} + \frac{j}{6} \times \frac{(\alpha+5)!}{(\alpha+1)!(c\gamma(\alpha+3)/2 + j\omega)^2} - \frac{j(\alpha+6)!}{4(\alpha+2)!(c\gamma(\alpha+5)/2 + j\omega)^2} + \frac{j(\alpha+8)!}{j(\alpha+7)!} - \frac{6(\alpha+3)!(c\gamma(\alpha+7)/2 + j\omega)^2}{24(\alpha+4)!(c\gamma(\alpha+9)/2 + j\omega)^2};$$

$$\frac{\partial W_5^{[5]\{P_5^{(\alpha,0)}(\tau,\gamma)\}}(j\omega)}{\partial \omega} = -\frac{j(\alpha+5)!}{120\alpha!(c\gamma(\alpha+1)/2 + j\omega)^2} + \frac{j}{24} \times \frac{(\alpha+6)!}{(\alpha+1)!(c\gamma(\alpha+3)/2 + j\omega)^2} - \frac{j(\alpha+7)!}{12(\alpha+2)!(c\gamma(\alpha+5)/2 + j\omega)^2} + \frac{j(\alpha+9)!}{j(\alpha+8)!} - \frac{12(\alpha+3)!(c\gamma(\alpha+7)/2 + j\omega)^2}{24(\alpha+4)!(c\gamma(\alpha+9)/2 + j\omega)^2} + \frac{j(\alpha+10)!}{120(\alpha+5)!(c\gamma(\alpha+11)/2 + j\omega)^2}.$$



Рис. 6.49. Вид производных преобразования Фурье ортогональных функций Якоби 2-го порядка: а)  $\gamma = 1, c = 2, \alpha \in [0; 4], \beta = 0$ ; б)  $\gamma \in [0, 75; 2], c = 2, \alpha = 1, \beta = 0$

[6.135] 
$$\frac{\partial W_k^{\{P_k^{(0,1)}(\tau, \gamma)\}}(j\omega)}{\partial \omega} = -j \sum_{s=0}^k \binom{k}{s} \binom{k+s+1}{s} (-1)^s \frac{1}{((2s+1)\gamma + j\omega)^2}$$

Частные случаи для производных преобразования Фурье функций 0-5 порядков:

$$\begin{aligned} \frac{\partial W_0^{\{P_0^{(0,1)}(\tau, \gamma)\}}(j\omega)}{\partial \omega} &= -\frac{j}{(\gamma + j\omega)^2}; \\ \frac{\partial W_1^{\{P_1^{(0,1)}(\tau, \gamma)\}}(j\omega)}{\partial \omega} &= -\frac{j}{(\gamma + j\omega)^2} + \frac{3j}{(3\gamma + j\omega)^2}; \\ \frac{\partial W_2^{\{P_2^{(0,1)}(\tau, \gamma)\}}(j\omega)}{\partial \omega} &= -\frac{j}{(\gamma + j\omega)^2} + \frac{8j}{(3\gamma + j\omega)^2} - \frac{10j}{(5\gamma + j\omega)^2}; \\ \frac{\partial W_3^{\{P_3^{(0,1)}(\tau, \gamma)\}}(j\omega)}{\partial \omega} &= -\frac{j}{(\gamma + j\omega)^2} + \frac{15j}{(3\gamma + j\omega)^2} - \frac{45j}{(5\gamma + j\omega)^2} + \frac{35j}{(7\gamma + j\omega)^2}; \\ \frac{\partial W_4^{\{P_4^{(0,1)}(\tau, \gamma)\}}(j\omega)}{\partial \omega} &= -\frac{j}{(\gamma + j\omega)^2} + \frac{24j}{(3\gamma + j\omega)^2} - \frac{126j}{(5\gamma + j\omega)^2} + \frac{224j}{(7\gamma + j\omega)^2} - \frac{126j}{(9\gamma + j\omega)^2}; \\ \frac{\partial W_5^{\{P_5^{(0,1)}(\tau, \gamma)\}}(j\omega)}{\partial \omega} &= -\frac{j}{(\gamma + j\omega)^2} + \frac{35j}{(3\gamma + j\omega)^2} - \frac{280j}{(5\gamma + j\omega)^2} + \frac{840j}{(7\gamma + j\omega)^2} - \frac{1050j}{(9\gamma + j\omega)^2} + \frac{462j}{(11\gamma + j\omega)^2}. \end{aligned}$$

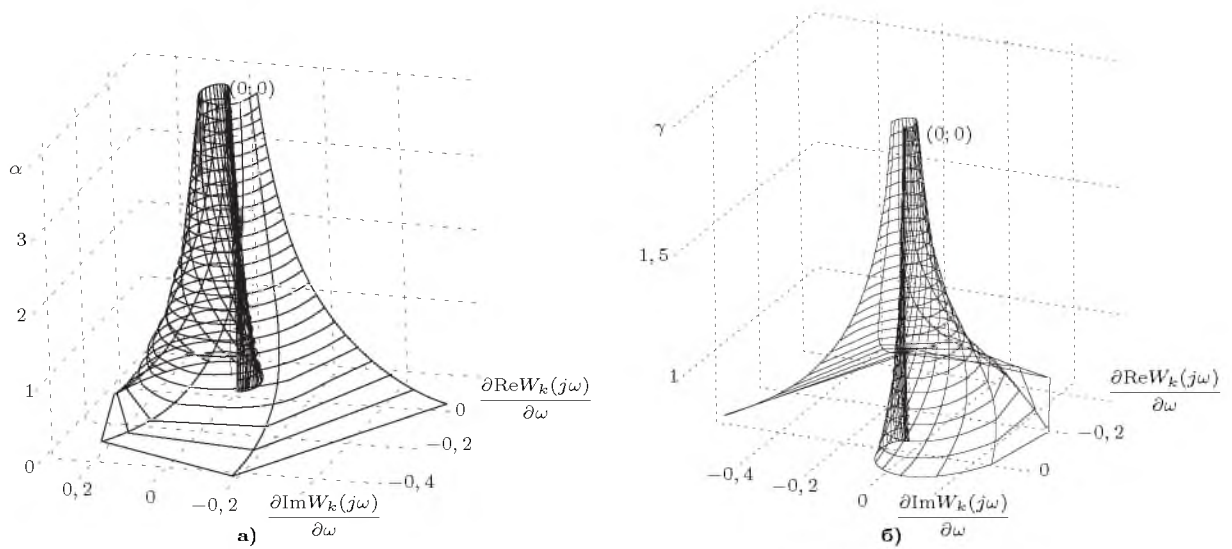

Рис. 6.50. Вид производных преобразования Фурье ортогональных функций Якоби 0-5 порядков;  $\gamma = 1, c = 2, \alpha = 0, \beta = 1$

[6.136] 
$$\frac{\partial W_k^{\{P_k^{(0,2)}(\tau, \gamma)\}}(j\omega)}{\partial \omega} = -j \sum_{s=0}^k \binom{k}{s} \binom{k+s+2}{s} (-1)^s \frac{1}{((2s+1)\gamma + j\omega)^2}$$

Частные случаи для производных преобразования Фурье функций 0-5 порядков:

$$\frac{\partial W_0^{\{P_0^{(0,2)}(\tau, \gamma)\}}(j\omega)}{\partial \omega} = -\frac{j}{(\gamma + j\omega)^2};$$

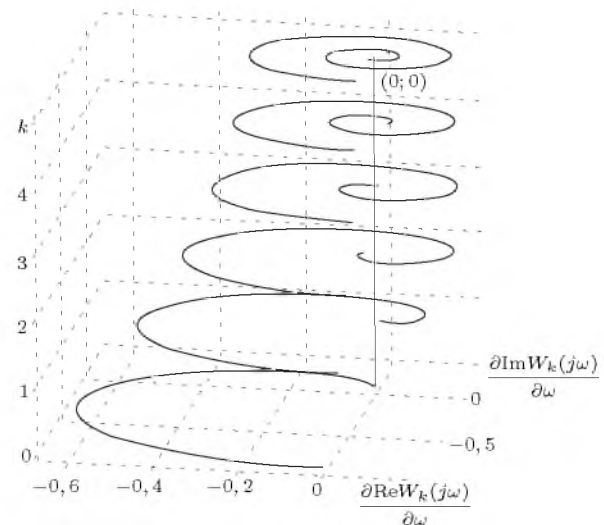

Рис. 6.51. Вид производных преобразования Фурье ортогональных функций Якоби 0-5 порядков;  $\gamma = 1, c = 2, \alpha = 0, \beta = 2$

[6.137] 
$$\frac{\partial W_k^{\{P_k^{(0,\beta)}(\tau,\gamma)\}}(j\omega)}{\partial \omega} = -j \sum_{s=0}^k \binom{k}{s} \times \binom{k+s+\beta}{s} (-1)^s \frac{1}{((2s+1)c\gamma/2 + j\omega)^2}.$$

Частные случаи для производных преобразования Фурье функций 0-5 порядков:

$$\frac{\partial W_0^{\{P_0^{(0,\beta)}(\tau,\gamma)\}}(j\omega)}{\partial \omega} = -\frac{j}{(c\gamma/2 + j\omega)^2};$$

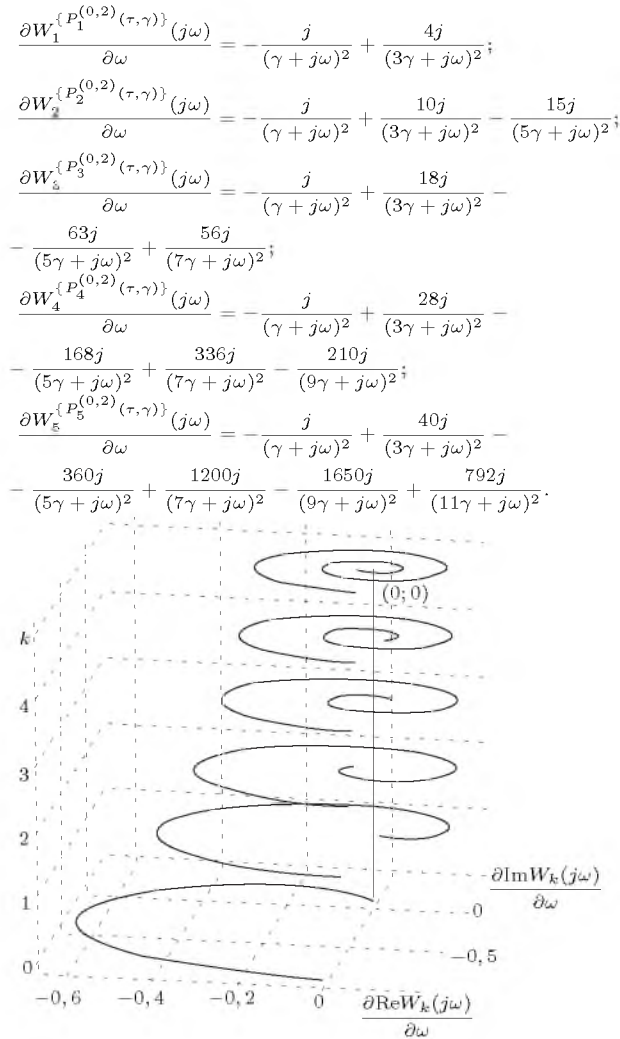
$$\frac{\partial W_1^{\{P_1^{(0,\beta)}(\tau,\gamma)\}}(j\omega)}{\partial \omega} = -\frac{j}{(c\gamma/2 + j\omega)^2} + \frac{j(\beta+2)}{(3c\gamma/2 + j\omega)^2};$$

$$\frac{\partial W_2^{\{P_2^{(0,\beta)}(\tau,\gamma)\}}(j\omega)}{\partial \omega} = -\frac{j}{2(c\gamma/2 + j\omega)^2} + \frac{2j(\beta+3)}{(3c\gamma/2 + j\omega)^2} - \frac{j(\beta+3)(\beta+4)}{2(5c\gamma/2 + j\omega)^2};$$

$$\frac{\partial W_3^{\{P_3^{(0,\beta)}(\tau,\gamma)\}}(j\omega)}{\partial \omega} = -\frac{j}{(c\gamma/2 + j\omega)^2} + \frac{3j(\beta+4)}{(3c\gamma/2 + j\omega)^2} - \frac{3j(\beta+3)(\beta+4)}{2(5c\gamma/2 + j\omega)^2} + \frac{j(\beta+6)!}{6(\beta+3)!(7c\gamma/2 + j\omega)^2};$$

$$\frac{\partial W_4^{\{P_4^{(0,\beta)}(\tau,\gamma)\}}(j\omega)}{\partial \omega} = -\frac{j}{(c\gamma/2 + j\omega)^2} + \frac{4j(\beta+5)}{(3c\gamma/2 + j\omega)^2} - \frac{3j(\beta+5)(\beta+6)}{(5c\gamma/2 + j\omega)^2} + \frac{2j(\beta+7)!}{3(\beta+4)!(7c\gamma/2 + j\omega)^2} - \frac{24(\beta+4)!(9c\gamma/2 + j\omega)^2}{j(\beta+8)!};$$

$$\frac{\partial W_5^{\{P_5^{(0,\beta)}(\tau,\gamma)\}}(j\omega)}{\partial \omega} = -\frac{j}{(c\gamma/2 + j\omega)^2} + \frac{5j(\beta+6)}{(3c\gamma/2 + j\omega)^2} - \frac{5j(\beta+6)(\beta+7)}{(5c\gamma/2 + j\omega)^2} + \frac{5j(\alpha+8)!}{3(\alpha+5)!(7c\gamma/2 + j\omega)^2} - \frac{5j(\beta+9)!}{24(\beta+5)!(9c\gamma/2 + j\omega)^2} + \frac{j(\beta+10)!}{120(\beta+5)!(11c\gamma/2 + j\omega)^2}.$$



Рис. 6.52. Вид производных преобразования Фурье ортогональных функций Якоби 2-ого порядка: а)  $\gamma = 1, c = 2, \alpha = 0, \beta \in [0; 5]$ ; б)  $\gamma \in [0, 75; 2], c = 2, \alpha = 0, \beta = 1$

### 6.5 Производные преобразований Фурье ортогональных фильтров

[6.138] 
$$\frac{\partial V_k^{[1]\{L_k(\tau, \gamma)\}}(j\omega)}{\partial \omega} = -\frac{j\gamma}{(j\omega + \gamma/2)^2} \sum_{s=0}^k \binom{k}{k-s} \left(\frac{-\gamma}{j\omega + \gamma/2}\right)^s (s+1).$$

[6.139] 
$$\frac{\partial V_k^{[2]\{L_k(\tau, \gamma)\}}(j\omega)}{\partial \omega} = -\frac{j\gamma(j\omega - \gamma(2k+1)/2)}{(j\omega + \gamma/2)^3} \left(\frac{j\omega - \gamma/2}{j\omega + \gamma/2}\right)^{k-1}.$$

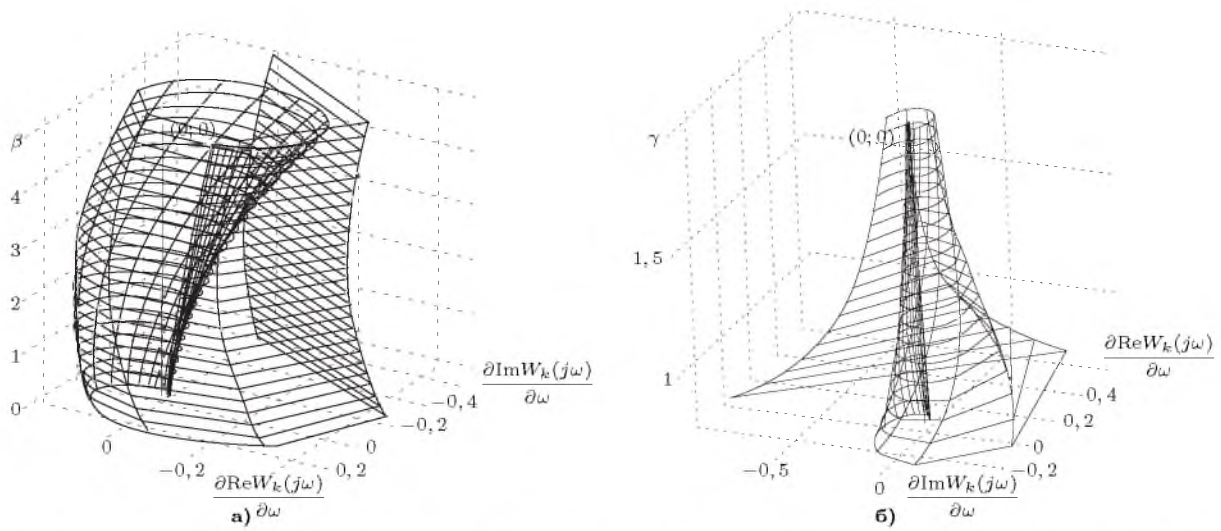
[6.140] 
$$\frac{\partial V_k^{[3]\{L_k(\tau, \gamma)\}}(j\omega)}{\partial \omega} = -\frac{4j}{\gamma} (-1)^k (\cos \varphi)^2 \times \exp(-j(2k+1)\varphi) ((2k+1) \cos \varphi - j \sin \varphi),$$
  

$$\varphi = \arctan \frac{2\omega}{\gamma}.$$

Частные случаи для производных преобразования Фурье фильтров 0-5 порядков:

$$\frac{\partial V_0^{[L_0(\tau, \gamma)]}(j\omega)}{\partial \omega} = \frac{\gamma(\omega + j\gamma/2)}{(j\omega - \gamma/2)(j\omega + \gamma/2)^2};$$

$$\frac{\partial V_1^{[L_1(\tau, \gamma)]}(j\omega)}{\partial \omega} = \frac{\gamma(\omega + 3j\gamma/2)}{(j\omega + \gamma/2)^3};$$

$$\frac{\partial V_2^{[L_2(\tau, \gamma)]}(j\omega)}{\partial \omega} = \frac{\gamma(\omega + 5j\gamma/2)(j\omega - \gamma/2)}{(j\omega + \gamma/2)^4};$$

$$\frac{\partial V_3^{[L_3(\tau, \gamma)]}(j\omega)}{\partial \omega} = \frac{\gamma(\omega + 7j\gamma/2)(j\omega - \gamma/2)^2}{(j\omega + \gamma/2)^5};$$

$$\frac{\partial V_4^{[L_4(\tau, \gamma)]}(j\omega)}{\partial \omega} = \frac{\gamma(\omega + 9j\gamma/2)(j\omega - \gamma/2)^3}{(j\omega + \gamma/2)^6};$$

$$\frac{\partial V_5^{[L_5(\tau, \gamma)]}(j\omega)}{\partial \omega} = \frac{\gamma(\omega + 11j\gamma/2)(j\omega - \gamma/2)^4}{(j\omega + \gamma/2)^7}.$$



Рис. 6.53. Вид производных преобразования Фурье ортогональных фильтров Лагерра 0-5 порядков;  $\gamma = 4$

[6.141] 
$$\frac{\partial V_k^{[1]\{L_k^{(1)}(\tau, \gamma)\}}(j\omega)}{\partial \omega} = -\frac{j\gamma^2}{(j\omega + \gamma/2)^3} \sum_{s=0}^k \binom{k}{k-s} \left(\frac{-\gamma}{j\omega + \gamma/2}\right)^s (s+2).$$

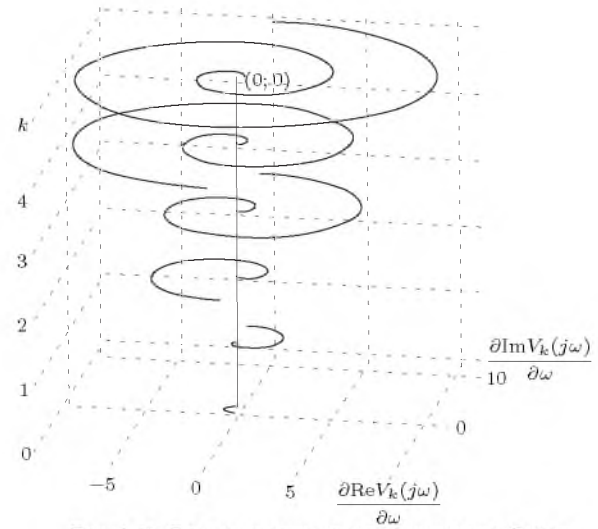

$$[6.142] \quad \frac{\partial V_k^{[2]\{L_k^{(1)}(\tau, \gamma)\}}(j\omega)}{\partial \omega} = -\frac{j\gamma^2(2j\omega - \gamma(2k+2)/2)}{(j\omega + \gamma/2)^4} \left(\frac{j\omega - \gamma/2}{j\omega + \gamma/2}\right)^{k-1}.$$

$$[6.143] \quad \frac{\partial V_k^{[3]\{L_k^{(1)}(\tau, \gamma)\}}(j\omega)}{\partial \omega} = -\frac{8j}{\gamma}(-1)^k(\cos \varphi)^3 \times \exp(-j(2k+2)\varphi)((2k+2)\cos \varphi - 2j \sin \varphi),$$

$$\varphi = \arctan \frac{2\omega}{\gamma}.$$

Частные случаи для производных преобразования Фурье фильтров 0-5 порядков:

$$\frac{\partial V_0^{[L_0^{(1)}(\tau, \gamma)]}(j\omega)}{\partial \omega} = \frac{2\gamma^2(\omega + j\gamma/2)}{(j\omega - \gamma/2)(j\omega + \gamma/2)^3};$$

$$\frac{\partial V_1^{[L_1^{(1)}(\tau, \gamma)]}(j\omega)}{\partial \omega} = \frac{2\gamma^2(\omega + j\gamma)}{(j\omega + \gamma/2)^4};$$

$$\frac{\partial V_2^{[L_2^{(1)}(\tau, \gamma)]}(j\omega)}{\partial \omega} = \frac{2\gamma^2(\omega + 3j\gamma/2)(j\omega - \gamma/2)}{(j\omega + \gamma/2)^5};$$

$$\frac{\partial V_3^{[L_3^{(1)}(\tau, \gamma)]}(j\omega)}{\partial \omega} = \frac{2\gamma^2(\omega + 2j\gamma)(j\omega - \gamma/2)^2}{(j\omega + \gamma/2)^6};$$

$$\frac{\partial V_4^{[L_4^{(1)}(\tau, \gamma)]}(j\omega)}{\partial \omega} = \frac{2\gamma^2(\omega + 5j\gamma/2)(j\omega - \gamma/2)^3}{(j\omega + \gamma/2)^7};$$

$$\frac{\partial V_5^{[L_5^{(1)}(\tau, \gamma)]}(j\omega)}{\partial \omega} = \frac{2\gamma^2(\omega + 3j\gamma)(j\omega - \gamma/2)^4}{(j\omega + \gamma/2)^8}.$$



Рис. 6.54. Вид производных преобразования Фурье ортогональных фильтров Сонина-Лагерра 0-5 порядков;  $\gamma = 4, \alpha = 1$

$$[6.144] \quad \frac{\partial V_k^{[1]\{L_k^{(2)}(\tau, \gamma)\}}(j\omega)}{\partial \omega} = -\frac{j\gamma^3}{(j\omega + \gamma/2)^4} \sum_{s=0}^k \binom{k}{k-s} \left(\frac{-\gamma}{j\omega + \gamma/2}\right)^s (s+3).$$

$$[6.145] \quad \frac{\partial V_k^{[2]\{L_k^{(2)}(\tau, \gamma)\}}(j\omega)}{\partial \omega} = -\frac{j\gamma^3(3j\omega - \gamma(2k+3)/2)}{(j\omega + \gamma/2)^5} \left(\frac{j\omega - \gamma/2}{j\omega + \gamma/2}\right)^{k-1}.$$

$$[6.146] \quad \frac{\partial V_k^{[3]\{L_k^{(2)}(\tau, \gamma)\}}(j\omega)}{\partial \omega} = -\frac{16j}{\gamma}(-1)^k(\cos \varphi)^4 \times \exp(-j(2k+3)\varphi)((2k+3)\cos \varphi - 3j \sin \varphi),$$

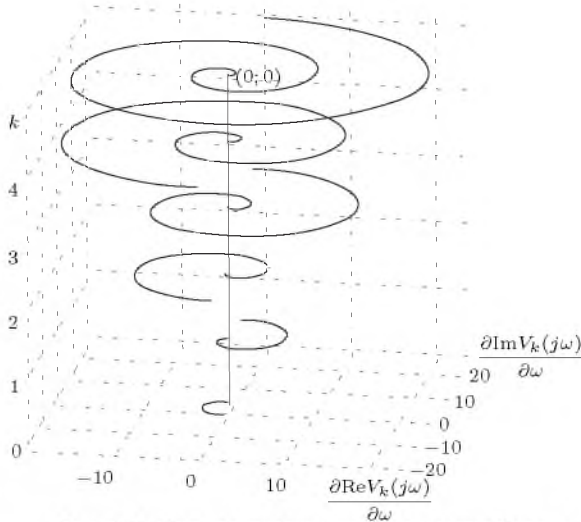
$$\varphi = \arctan \frac{2\omega}{\gamma}.$$

Частные случаи для производных преобразования Фурье фильтров 0-5 порядков:

$$\frac{\partial V_0^{[L_0^{(2)}(\tau, \gamma)]}(j\omega)}{\partial \omega} = \frac{3\gamma^3(\omega + j\gamma/2)}{(j\omega - \gamma/2)(j\omega + \gamma/2)^4};$$

$$\frac{\partial V_1^{[L_1^{(2)}(\tau, \gamma)]}(j\omega)}{\partial \omega} = \frac{\gamma^3(3\omega + 5j\gamma/2)}{(j\omega + \gamma/2)^5};$$

$$\frac{\partial V_2^{[L_2^{(2)}(\tau, \gamma)]}(j\omega)}{\partial \omega} = \frac{\gamma^3(3\omega + 7j\gamma/2)(j\omega - \gamma/2)}{(j\omega + \gamma/2)^6};$$

$$\frac{\partial V_3^{[L_3^{(2)}(\tau, \gamma)]}(j\omega)}{\partial \omega} = \frac{\gamma^3(3\omega + 9j\gamma/2)(j\omega - \gamma/2)^2}{(j\omega + \gamma/2)^7};$$

$$\frac{\partial V_4^{[L_4^{(2)}(\tau, \gamma)]}(j\omega)}{\partial \omega} = \frac{\gamma^3(3\omega + 11j\gamma/2)(j\omega - \gamma/2)^3}{(j\omega + \gamma/2)^8};$$

$$\frac{\partial V_5^{[L_5^{(2)}(\tau, \gamma)]}(j\omega)}{\partial \omega} = \frac{\gamma^3(3\omega + 13j\gamma/2)(j\omega - \gamma/2)^4}{(j\omega + \gamma/2)^9}.$$



Рис. 6.55. Вид производных преобразования Фурье ортогональных фильтров Сонина-Лагерра 0-5 порядков;  $\gamma = 4, \alpha = 2$

$$[6.147] \quad \frac{\partial V_k^{[1]\{L_k^{(\alpha)}(\tau, \gamma)\}}(j\omega)}{\partial \omega} = -\frac{j\gamma^{\alpha+1}}{(j\omega + \gamma/2)^{\alpha+2}} \sum_{s=0}^k \binom{k}{k-s} \left(\frac{-\gamma}{j\omega + \gamma/2}\right)^s (s+\alpha+1).$$

$$[6.148] \quad \frac{\partial V_k^{[2]\{L_k^{(\alpha)}(\tau, \gamma)\}}(j\omega)}{\partial \omega} = -j\gamma^{\alpha+1} \times \frac{((\alpha+1)j\omega - \gamma(2k + \alpha + 1)/2)}{(j\omega + \gamma/2)^{\alpha+3}} \left(\frac{j\omega - \gamma/2}{j\omega + \gamma/2}\right)^{k-1}.$$

$$[6.149] \quad \frac{\partial V_k^{[3]\{L_k^{(\alpha)}(\tau, \gamma)\}}(j\omega)}{\partial \omega} = -\frac{2^{\alpha+2} j}{\gamma} (-1)^k \times (\cos \varphi)^{\alpha+2} \exp(-j(2k + \alpha + 1)\varphi) \times ((2k + \alpha + 1) \cos \varphi - j(\alpha + 1) \sin \varphi), \quad \varphi = \arctan \frac{2\omega}{\gamma}.$$

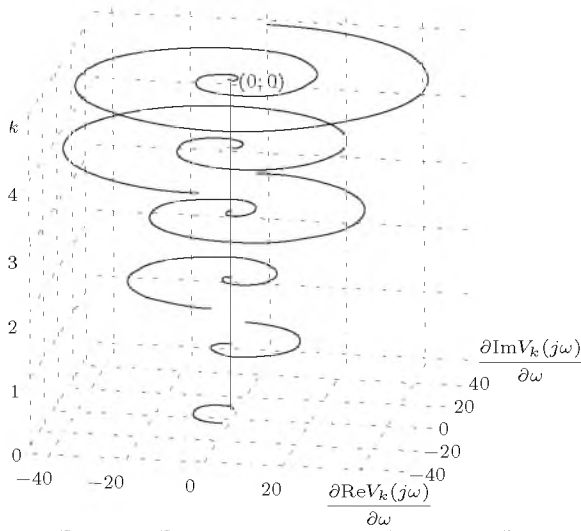
Частные случаи для производных преобразования Фурье фильтров 0-5 порядков:

$$\frac{\partial V_0^{(L_0^{(\alpha)}(\tau, \gamma))}(j\omega)}{\partial \omega} = \frac{\gamma^{\alpha+1} ((\alpha+1)\omega + j(\alpha+1)\gamma/2)}{(j\omega - \gamma/2)(j\omega + \gamma/2)^{\alpha+2}};$$

$$\frac{\partial V_1^{(L_1^{(\alpha)}(\tau, \gamma))}(j\omega)}{\partial \omega} = \frac{\gamma^{\alpha+1} ((\alpha+1)\omega + j(\alpha+3)\gamma/2)}{(j\omega + \gamma/2)^{\alpha+3}};$$

$$\frac{\partial V_2^{(L_2^{(\alpha)}(\tau, \gamma))}(j\omega)}{\partial \omega} = \frac{\gamma^{\alpha+1} ((\alpha+1)\omega + j(\alpha+5)\gamma/2)}{(j\omega + \gamma/2)^{\alpha+4}} \times (j\omega - \gamma/2);$$

$$\frac{\partial V_3^{(L_3^{(\alpha)}(\tau, \gamma))}(j\omega)}{\partial \omega} = \frac{\gamma^{\alpha+1} ((\alpha+1)\omega + j(\alpha+7)\gamma/2)}{(j\omega + \gamma/2)^{\alpha+5}} \times (j\omega - \gamma/2)^2;$$

$$\frac{\partial V_4^{(L_4^{(\alpha)}(\tau, \gamma))}(j\omega)}{\partial \omega} = \frac{\gamma^{\alpha+1} ((\alpha+1)\omega + j(\alpha+9)\gamma/2)}{(j\omega + \gamma/2)^{\alpha+6}} \times (j\omega - \gamma/2)^3;$$

$$\frac{\partial V_5^{(L_5^{(\alpha)}(\tau, \gamma))}(j\omega)}{\partial \omega} = \frac{\gamma^{\alpha+1} ((\alpha+1)\omega + j(\alpha+11)\gamma/2)}{(j\omega + \gamma/2)^{\alpha+7}} \times (j\omega - \gamma/2)^4.$$



Рис. 6.56. Вид производных преобразования Фурье ортогональных фильтров Сонина-Лагерра 2-ого порядка: а)  $\gamma = 4, \alpha \in [1; 4]$ ; б)  $\gamma \in [2; 4], \alpha = 1$

$$[6.150] \quad \frac{\partial V_k^{[1]\{P_k^{(-1/2,0)}(\tau,\gamma)\}}(j\omega)}{\partial \omega} = -j(4k+1)\gamma \times \sum_{s=0}^k \binom{k}{s} \binom{k+s-1/2}{s-1/2} (-1)^s \frac{1}{((4s+1)\gamma/2 + j\omega)^2}.$$

$$[6.151] \quad \frac{\partial V_k^{[2]\{P_k^{(-1/2,0)}(\tau,\gamma)\}}(j\omega)}{\partial \omega} = \begin{cases} \frac{j\gamma}{(\gamma/2 + j\omega)^2}, & \text{если } k = 0; \\ \frac{j(4k+1)\gamma}{(4k+1)\gamma/2 + j\omega} \times \prod_{s=0}^{k-1} \frac{(4s+1)\gamma/2 - j\omega}{(4s+1)\gamma/2 + j\omega} \times \left( \frac{1}{(4k+1)\gamma/2 + j\omega} + \gamma \sum_{s=0}^{k-1} \frac{4s+1}{((4s+1)\gamma/2)^2 + \omega^2} \right), & \text{если } k > 0. \end{cases}$$

$$[6.152] \quad \frac{\partial V_k^{[3]\{P_k^{(-1/2,0)}(\tau,\gamma)\}}(j\omega)}{\partial \omega} = \begin{cases} -\frac{4j(\cos \varphi_0)^2}{\gamma} \exp(-2j\varphi_0), & \text{если } k = 0; \\ -2j \cos \varphi_k \times \exp\left(-j\left(\varphi_k + 2 \sum_{s=0}^{k-1} \varphi_s\right)\right) \times \left( \frac{2 \cos \varphi_k \exp(-j\varphi_k)}{(4k+1)\gamma} + \frac{4}{\gamma} \sum_{s=0}^{k-1} \frac{(\cos \varphi_k)^2}{4s+1} \right), & \text{если } k > 0, \end{cases}$$

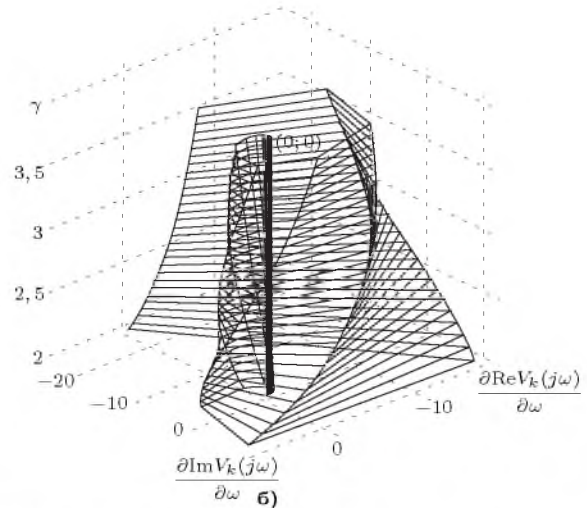
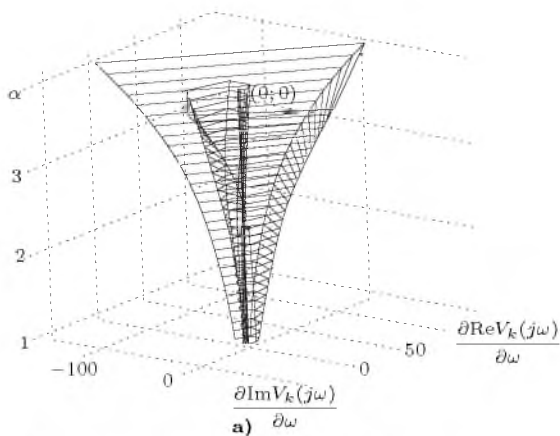
$$\varphi_k = \arctan \frac{2\omega}{(4k+1)\gamma}.$$

Частные случаи для производных преобразования Фурье фильтров 0-5 порядков:

$$\frac{\partial V_0^{[P_0^{(-1/2,0)}(\tau,\gamma)]}(j\omega)}{\partial \omega} = -\frac{j\gamma}{(\gamma/2 + j\omega)^2};$$

$$\frac{\partial V_1^{[P_1^{(-1/2,0)}(\tau,\gamma)]}(j\omega)}{\partial \omega} = -\frac{5j\gamma}{2(\gamma/2 + j\omega)^2} + \frac{15j\gamma}{2(5\gamma/2 + j\omega)^2};$$

$$\frac{\partial V_2^{[P_2^{(-1/2,0)}(\tau,\gamma)]}(j\omega)}{\partial \omega} = -\frac{27j\gamma}{8(\gamma/2 + j\omega)^2} + \frac{135j\gamma}{4(5\gamma/2 + j\omega)^2} - \frac{315j\gamma}{8(9\gamma/2 + j\omega)^2};$$

$$\frac{\partial V_3^{[P_3^{(-1/2,0)}(\tau,\gamma)]}(j\omega)}{\partial \omega} = -\frac{65j\gamma}{16(\gamma/2 + j\omega)^2} + \frac{1365j\gamma}{16(5\gamma/2 + j\omega)^2} - \frac{4095j\gamma}{16(9\gamma/2 + j\omega)^2} + \frac{3003j\gamma}{16(13\gamma/2 + j\omega)^2};$$

$$\frac{\partial V_4^{[P_4^{(-1/2,0)}(\tau,\gamma)]}(j\omega)}{\partial \omega} = -\frac{595j\gamma}{128(\gamma/2 + j\omega)^2} + \frac{5355j\gamma}{32} \times \frac{1}{(5\gamma/2 + j\omega)^2} - \frac{58905j\gamma}{64(9\gamma/2 + j\omega)^2} + \frac{51051j\gamma}{32(13\gamma/2 + j\omega)^2} -$$



Рис. 6.57. Вид производных преобразования Фурье ортогональных фильтров Якоби 0-5 порядков;  $\gamma = 1, c = 2, \alpha = -1/2, \beta = 0$

$$[6.153] \quad \frac{\partial V_k^{[1]\{Leg_k(\tau,\gamma)\}}(j\omega)}{\partial \omega} = -2j(2k+1)\gamma \sum_{s=0}^k \binom{k}{s} \binom{k+s}{s} (-1)^s \frac{1}{((2s+1)\gamma + j\omega)^2}.$$

$$[6.154] \quad \frac{\partial V_k^{[2]\{Leg_k(\tau,\gamma)\}}(j\omega)}{\partial \omega} = \begin{cases} -\frac{2j\gamma}{(\gamma + j\omega)^2}, & \text{если } k = 0; \\ -\frac{2j(2k+1)\gamma}{(2k+1)\gamma + j\omega} \times \prod_{s=0}^{k-1} \frac{(2s+1)\gamma - j\omega}{(2s+1)\gamma + j\omega} \times \left( \frac{1}{(2k+1)\gamma + j\omega} + 2\gamma \sum_{s=0}^{k-1} \frac{2s+1}{((2s+1)\gamma)^2 + \omega^2} \right), & \text{если } k > 0. \end{cases}$$

$$[6.155] \quad \frac{\partial V_k^{[3]\{Leg_k(\tau, \gamma)\}}(j\omega)}{\partial \omega} = \begin{cases} \left[ \begin{aligned} & -\frac{2j(\cos \varphi_0)^2}{\gamma} \exp(-2j\varphi_0), & \text{если } k = 0; \\ & -2j \cos \varphi_k \times \\ & \times \exp\left(-j\left(\varphi_k + 2 \sum_{s=0}^{k-1} \varphi_s\right)\right) \times \\ & \times \left( \frac{\cos \varphi_k \exp(-j\varphi_k)}{(2k+1)\gamma} + \right. \\ & \left. + \frac{2}{\gamma} \sum_{s=0}^{k-1} \frac{(\cos \varphi_k)^2}{2s+1} \right), & \text{если } k > 0, \end{aligned} \right. \\ \varphi_k = \arctan \frac{\omega}{(2k+1)\gamma}. \end{cases}$$

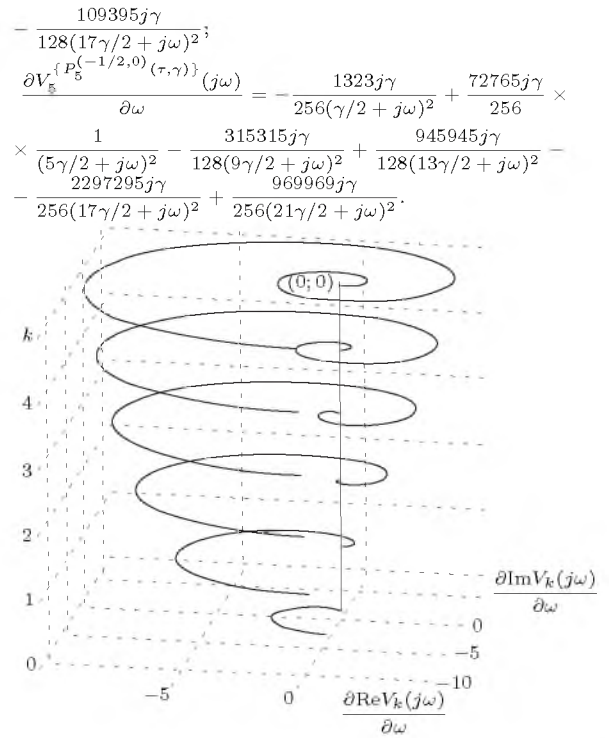
Частные случаи для производных преобразования Фурье фильтров 0-5 порядков:

$$\begin{aligned} \frac{\partial V_0^{[3]\{Leg_0(\tau, \gamma)\}}(j\omega)}{\partial \omega} &= -\frac{2j\gamma}{(\gamma + j\omega)^2}; \\ \frac{\partial V_1^{[3]\{Leg_1(\tau, \gamma)\}}(j\omega)}{\partial \omega} &= -\frac{6j\gamma}{(\gamma + j\omega)^2} + \frac{12j\gamma}{(3\gamma + j\omega)^2}; \\ \frac{\partial V_2^{[3]\{Leg_2(\tau, \gamma)\}}(j\omega)}{\partial \omega} &= -\frac{10j\gamma}{(\gamma + j\omega)^2} + \frac{60j\gamma}{(3\gamma + j\omega)^2} - \frac{6j\gamma}{(5\gamma + j\omega)^2}; \\ \frac{\partial V_3^{[3]\{Leg_3(\tau, \gamma)\}}(j\omega)}{\partial \omega} &= -\frac{14j\gamma}{(\gamma + j\omega)^2} + \frac{168j\gamma}{(3\gamma + j\omega)^2} - \\ & - \frac{420j\gamma}{(5\gamma + j\omega)^2} + \frac{280j\gamma}{(7\gamma + j\omega)^2}; \\ \frac{\partial V_4^{[3]\{Leg_4(\tau, \gamma)\}}(j\omega)}{\partial \omega} &= -\frac{18j\gamma}{(\gamma + j\omega)^2} + \frac{360j\gamma}{(3\gamma + j\omega)^2} - \\ & - \frac{1620j\gamma}{(5\gamma + j\omega)^2} + \frac{2520j\gamma}{(7\gamma + j\omega)^2} - \frac{1260j\gamma}{(9\gamma + j\omega)^2}; \\ \frac{\partial V_5^{[3]\{Leg_5(\tau, \gamma)\}}(j\omega)}{\partial \omega} &= -\frac{22j\gamma}{(\gamma + j\omega)^2} + \frac{660j\gamma}{(3\gamma + j\omega)^2} - \\ & - \frac{4620j\gamma}{(5\gamma + j\omega)^2} + \frac{12320j\gamma}{(7\gamma + j\omega)^2} - \frac{13860j\gamma}{(9\gamma + j\omega)^2} + \frac{5544j\gamma}{(11\gamma + j\omega)^2}. \end{aligned}$$



Рис. 6.58. Вид производных преобразования Фурье ортогональных фильтров Лежандра 0-5 порядков;  $\gamma = 1, c = 2$

$$[6.156] \quad \frac{\partial V_k^{[1]\{P_k^{(1/2,0)}(\tau, \gamma)\}}(j\omega)}{\partial \omega} = -j(4k+3)\gamma \times \sum_{s=0}^k \binom{k}{s} \binom{k+s+1/2}{s+1/2} (-1)^s \frac{1}{((4s+3)\gamma/2 + j\omega)^2}.$$

$$[6.157] \quad \frac{\partial V_k^{[2]\{P_k^{(1/2,0)}(\tau, \gamma)\}}(j\omega)}{\partial \omega} = \begin{cases} -\frac{3j\gamma}{(3\gamma/2 + j\omega)^2}, & \text{если } k = 0; \\ -\frac{(4k+3)\gamma/2 + j\omega}{j(4k+3)\gamma} \times \\ \times \prod_{s=0}^{k-1} \frac{(4s+3)\gamma/2 - j\omega}{(4s+3)\gamma/2 + j\omega} \times \\ \times \left( \frac{1}{(4k+3)\gamma/2 + j\omega} + \right. \\ \left. + \gamma \sum_{s=0}^{k-1} \frac{4s+3}{((4s+3)\gamma/2)^2 + \omega^2} \right), & \text{если } k > 0. \end{cases}$$

$$[6.158] \quad \frac{\partial V_k^{[3]\{P_k^{(1/2,0)}(\tau, \gamma)\}}(j\omega)}{\partial \omega} = \begin{cases} -\frac{4j(\cos \varphi_0)^2}{3\gamma} \exp(-2j\varphi_0), & \text{если } k = 0; \\ -2j \cos \varphi_k \times \\ \times \exp\left(-j\left(\varphi_k + 2 \sum_{s=0}^{k-1} \varphi_s\right)\right) \times \\ \times \left( \frac{2 \cos \varphi_k \exp(-j\varphi_k)}{(4k+3)\gamma} + \right. \\ \left. + \frac{4}{\gamma} \sum_{s=0}^{k-1} \frac{(\cos \varphi_k)^2}{4s+3} \right), & \text{если } k > 0, \end{cases} \\ \varphi_k = \arctan \frac{2\omega}{(4k+3)\gamma}.$$

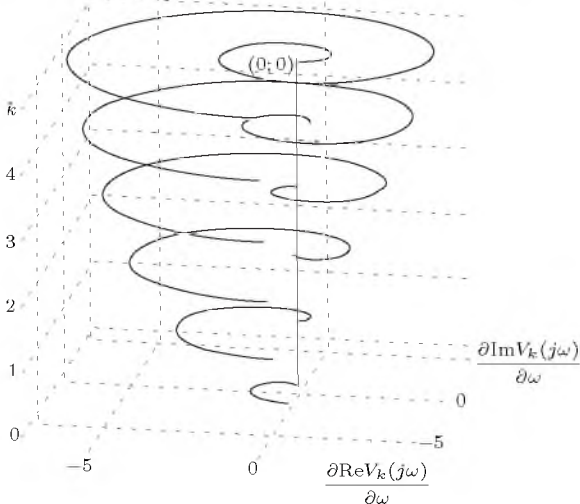
Частные случаи для производных преобразования Фурье фильтров 0-5 порядков:

$$\begin{aligned} \frac{\partial V_0^{[1]\{P_0^{(1/2,0)}(\tau, \gamma)\}}(j\omega)}{\partial \omega} &= -\frac{3j\gamma}{(3\gamma/2 + j\omega)^2}; \\ \frac{\partial V_1^{[1]\{P_1^{(1/2,0)}(\tau, \gamma)\}}(j\omega)}{\partial \omega} &= -\frac{35j\gamma}{2(3\gamma/2 + j\omega)^2} + \frac{105j\gamma}{2(7\gamma/2 + j\omega)^2}; \\ \frac{\partial V_2^{[1]\{P_2^{(1/2,0)}(\tau, \gamma)\}}(j\omega)}{\partial \omega} &= -\frac{297j\gamma}{8(3\gamma/2 + j\omega)^2} + \frac{1485j\gamma}{4(7\gamma/2 + j\omega)^2} - \\ & - \frac{3465j\gamma}{8(11\gamma/2 + j\omega)^2}; \\ \frac{\partial V_3^{[1]\{P_3^{(1/2,0)}(\tau, \gamma)\}}(j\omega)}{\partial \omega} &= -\frac{975j\gamma}{16(3\gamma/2 + j\omega)^2} + \frac{20475j\gamma}{16(7\gamma/2 + j\omega)^2} - \\ & - \frac{61425j\gamma}{16(11\gamma/2 + j\omega)^2} + \frac{45045j\gamma}{16(15\gamma/2 + j\omega)^2}; \\ \frac{\partial V_4^{[1]\{P_4^{(1/2,0)}(\tau, \gamma)\}}(j\omega)}{\partial \omega} &= -\frac{11305j\gamma}{128(3\gamma/2 + j\omega)^2} + \frac{101745j\gamma}{32} \times \\ & \times \frac{1}{(7\gamma/2 + j\omega)^2} - \frac{1119195j\gamma}{64(11\gamma/2 + j\omega)^2} + \frac{969969j\gamma}{32(15\gamma/2 + j\omega)^2} - \\ & - \frac{2078505j\gamma}{128(19\gamma/2 + j\omega)^2}; \end{aligned}$$



Рис. 6.59. Вид производных преобразования Фурье ортогональных фильтров Якоби 0-5 порядков;  $\gamma = 1, c = 2, \alpha = 1/2, \beta = 0$

[6.161] 
$$\frac{\partial V_k^{\{P_k^{(1,0)}(\tau,\gamma)\}}(j\omega)}{\partial \omega} =$$

$$= \begin{cases} -\frac{2j(\cos \varphi_0)^2}{\gamma} \exp(-2j\varphi_0), & \text{если } k = 0; \\ -2j \cos \varphi_k \times \\ \times \exp\left(-j\left(\varphi_k + 2 \sum_{s=0}^{k-1} \varphi_s\right)\right) \times \\ \times \left(\frac{\cos \varphi_k \exp(-j\varphi_k)}{(k+1)\gamma} + \right. \\ \left. + \frac{2}{\gamma} \sum_{s=0}^{k-1} \frac{(\cos \varphi_k)^2}{s+1}\right), & \text{если } k > 0, \end{cases}$$

$$\varphi_k = \arctan \frac{\omega}{(k+1)\gamma}.$$

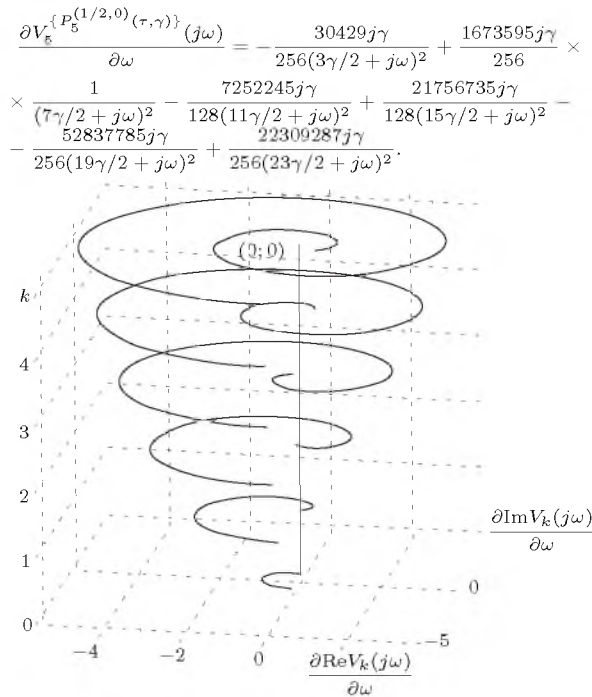
[6.159] 
$$\frac{\partial V_k^{\{P_k^{(1,0)}(\tau,\gamma)\}}(j\omega)}{\partial \omega} = -2j(k+1)\gamma \times$$

$$\times \sum_{s=0}^k \binom{k}{s} \binom{k+s+1}{s+1} (-1)^s \frac{1}{((s+1)\gamma + j\omega)^2}.$$

[6.160] 
$$\frac{\partial V_k^{\{P_k^{(1,0)}(\tau,\gamma)\}}(j\omega)}{\partial \omega} =$$

$$= \begin{cases} -\frac{2j\gamma}{(\gamma + j\omega)^2}, & \text{если } k = 0; \\ -\frac{2j(k+1)\gamma}{(k+1)\gamma + j\omega} \times \\ \times \prod_{s=0}^{k-1} \frac{(s+1)\gamma - j\omega}{(s+1)\gamma + j\omega} \times \\ \times \left(\frac{1}{(k+1)\gamma + j\omega} + \right. \\ \left. + 2\gamma \sum_{s=0}^{k-1} \frac{s+1}{((s+1)\gamma)^2 + \omega^2}\right), & \text{если } k > 0. \end{cases}$$

Частные случаи для производных преобразования Фурье фильтров 0-5 порядков:

$$\frac{\partial V_0^{\{P_0^{(1,0)}(\tau,\gamma)\}}(j\omega)}{\partial \omega} = -\frac{2j\gamma}{(\gamma + j\omega)^2};$$

$$\frac{\partial V_1^{\{P_1^{(1,0)}(\tau,\gamma)\}}(j\omega)}{\partial \omega} = -\frac{8j\gamma}{(\gamma + j\omega)^2} + \frac{12j\gamma}{(2\gamma + j\omega)^2};$$

$$\frac{\partial V_2^{\{P_2^{(1,0)}(\tau,\gamma)\}}(j\omega)}{\partial \omega} = -\frac{18j\gamma}{(\gamma + j\omega)^2} + \frac{72j\gamma}{(2\gamma + j\omega)^2} - \frac{60j\gamma}{(3\gamma + j\omega)^2};$$

$$\frac{\partial V_3^{\{P_3^{(1,0)}(\tau,\gamma)\}}(j\omega)}{\partial \omega} = -\frac{32j\gamma}{(\gamma + j\omega)^2} + \frac{240j\gamma}{(2\gamma + j\omega)^2} -$$

$$- \frac{480j\gamma}{(3\gamma + j\omega)^2} + \frac{280j\gamma}{(4\gamma + j\omega)^2};$$

$$\frac{\partial V_4^{\{P_4^{(1,0)}(\tau,\gamma)\}}(j\omega)}{\partial \omega} = -\frac{50j\gamma}{(\gamma + j\omega)^2} + \frac{600j\gamma}{(2\gamma + j\omega)^2} -$$

$$- \frac{2100j\gamma}{(3\gamma + j\omega)^2} + \frac{2800j\gamma}{(4\gamma + j\omega)^2} - \frac{1260j\gamma}{(5\gamma + j\omega)^2};$$

$$\frac{\partial V_5^{\{P_5^{(1,0)}(\tau,\gamma)\}}(j\omega)}{\partial \omega} = -\frac{72j\gamma}{(\gamma + j\omega)^2} + \frac{1260j\gamma}{(2\gamma + j\omega)^2} -$$

$$- \frac{6720j\gamma}{(3\gamma + j\omega)^2} + \frac{15120j\gamma}{(4\gamma + j\omega)^2} - \frac{15120j\gamma}{(5\gamma + j\omega)^2} + \frac{5544j\gamma}{(6\gamma + j\omega)^2}.$$



Рис. 6.60. Вид производных преобразования Фурье ортогональных фильтров Якоби 0-5 порядков;  $\gamma = 1, c = 1, \alpha = 1, \beta = 0$

$$[6.162] \quad \frac{\partial V_k^{[1]\{P_k^{(2,0)}(\tau, \gamma)\}}(j\omega)}{\partial \omega} = -2j(2k+3)\gamma \times \sum_{s=0}^k \binom{k}{s} \binom{k+s+2}{s+2} (-1)^s \frac{1}{((2s+3)\gamma + j\omega)^2}$$

$$[6.163] \quad \frac{\partial V_k^{[2]\{P_k^{(2,0)}(\tau, \gamma)\}}(j\omega)}{\partial \omega} = \begin{cases} -\frac{2j\gamma}{(\gamma + j\omega)^2}, & \text{если } k = 0; \\ -\frac{2j(2k+3)\gamma}{(2k+3)\gamma + j\omega} \times \prod_{s=0}^{k-1} \frac{(2s+3)\gamma - j\omega}{(2s+3)\gamma + j\omega} \times \left( \frac{1}{(2k+3)\gamma + j\omega} + 2\gamma \sum_{s=0}^{k-1} \frac{2s+3}{((2s+3)\gamma)^2 + \omega^2} \right), & \text{если } k > 0. \end{cases}$$

$$[6.164] \quad \frac{\partial V_k^{[3]\{P_k^{(2,0)}(\tau, \gamma)\}}(j\omega)}{\partial \omega} = \begin{cases} -\frac{2j(\cos \varphi_0)^2}{\gamma} \exp(-2j\varphi_0), & \text{если } k = 0; \\ -2j \cos \varphi_k \times \exp\left(-j\left(\varphi_k + 2 \sum_{s=0}^{k-1} \varphi_s\right)\right) \times \left( \frac{\cos \varphi_k \exp(-j\varphi_k)}{(2k+3)\gamma} + \frac{2}{\gamma} \sum_{s=0}^{k-1} \frac{(\cos \varphi_k)^2}{2s+3} \right), & \text{если } k > 0, \end{cases}$$

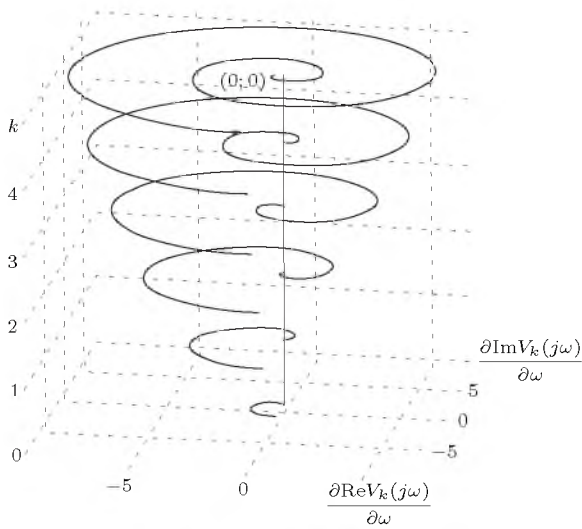
$$\varphi_k = \arctan \frac{\omega}{(2k+3)\gamma}$$

Частные случаи для производных преобразования Фурье фильтров 0-5 порядков:

$$\begin{aligned} \frac{\partial V_0^{[P_0^{(2,0)}(\tau, \gamma)]}(j\omega)}{\partial \omega} &= -\frac{6j\gamma}{(3\gamma + j\omega)^2}; \\ \frac{\partial V_1^{[P_1^{(2,0)}(\tau, \gamma)]}(j\omega)}{\partial \omega} &= -\frac{30j\gamma}{(3\gamma + j\omega)^2} + \frac{40j\gamma}{(5\gamma + j\omega)^2}; \\ \frac{\partial V_2^{[P_2^{(2,0)}(\tau, \gamma)]}(j\omega)}{\partial \omega} &= -\frac{84j\gamma}{(3\gamma + j\omega)^2} + \frac{280j\gamma}{(5\gamma + j\omega)^2} - \frac{210j\gamma}{(7\gamma + j\omega)^2}; \\ \frac{\partial V_3^{[P_3^{(2,0)}(\tau, \gamma)]}(j\omega)}{\partial \omega} &= -\frac{180j\gamma}{(3\gamma + j\omega)^2} + \frac{1080j\gamma}{(5\gamma + j\omega)^2} - \frac{1890j\gamma}{(7\gamma + j\omega)^2} + \frac{1008j\gamma}{(9\gamma + j\omega)^2}; \\ \frac{\partial V_4^{[P_4^{(2,0)}(\tau, \gamma)]}(j\omega)}{\partial \omega} &= -\frac{330j}{(3\gamma + j\omega)^2} + \frac{3080j}{(5\gamma + j\omega)^2} - \frac{9240j\gamma}{(7\gamma + j\omega)^2} + \frac{11880j\gamma}{(9\gamma + j\omega)^2} - \frac{4620j\gamma}{(11\gamma + j\omega)^2}; \\ \frac{\partial V_5^{[P_5^{(2,0)}(\tau, \gamma)]}(j\omega)}{\partial \omega} &= -\frac{546j\gamma}{(3\gamma + j\omega)^2} + \frac{7280j\gamma}{(5\gamma + j\omega)^2} - \frac{32760j\gamma}{(7\gamma + j\omega)^2} + \frac{65520j\gamma}{(9\gamma + j\omega)^2} - \frac{60060j\gamma}{(11\gamma + j\omega)^2} + \frac{20592j\gamma}{(13\gamma + j\omega)^2}. \end{aligned}$$



Рис. 6.61. Вид производных преобразования Фурье ортогональных фильтров Якоби 0-5 порядков;  $\gamma = 1, c = 2, \alpha = 2, \beta = 0$

[6.165]

$$\frac{\partial V_k^{[1]\{P_k^{(\alpha,0)}(\tau,\gamma)\}}(j\omega)}{\partial \omega} = -j(2k + \alpha + 1)c\gamma \sum_{s=0}^k \binom{k}{s} \times \binom{k+s+\alpha}{s+\alpha} (-1)^s \frac{1}{((2s + \alpha + 1)c\gamma/2 + j\omega)^2}$$

[6.166]

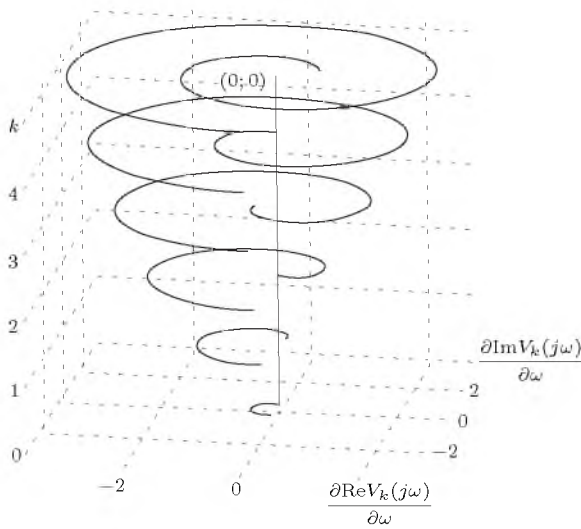
$$\frac{\partial V_k^{[2]\{P_k^{(\alpha,0)}(\tau,\gamma)\}}(j\omega)}{\partial \omega} = \begin{cases} -\frac{j(\alpha + 1)c\gamma}{((\alpha + 1)c\gamma/2 + j\omega)^2}, & \text{если } k = 0; \\ \frac{j(2k + \alpha + 1)c\gamma}{j(2k + \alpha + 1)c\gamma} \times \prod_{s=0}^{k-1} \frac{(2s + \alpha + 1)c\gamma/2 - j\omega}{(2s + \alpha + 1)c\gamma/2 + j\omega} \times \left( \frac{1}{(2k + \alpha + 1)c\gamma/2 + j\omega} + 2c\gamma/2 \times \sum_{s=0}^{k-1} \frac{2s + \alpha + 1}{((2s + \alpha + 1)c\gamma/2)^2 + \omega^2} \right), & \text{если } k > 0. \end{cases}$$

[6.167]

$$\frac{\partial V_k^{[3]\{P_k^{(\alpha,0)}(\tau,\gamma)\}}(j\omega)}{\partial \omega} = \begin{cases} -\frac{4j(\cos \varphi_0)^2}{(\alpha + 1)c\gamma} \exp(-2j\varphi_0), & \text{если } k = 0; \\ -2j \cos \varphi_k \times \exp\left(-j\left(\varphi_k + 2 \sum_{s=0}^{k-1} \varphi_s\right)\right) \times \left( \frac{\cos \varphi_k \exp(-j\varphi_k)}{(2k + \alpha + 1)c\gamma/2} + \frac{4}{c\gamma} \sum_{s=0}^{k-1} \frac{(\cos \varphi_k)^2}{2s + \alpha + 1} \right), & \text{если } k > 0, \end{cases}$$

$$\varphi_k = \arctan \frac{2\omega}{(2k + \alpha + 1)c\gamma}$$

Частные случаи для производных преобразования Фурье фильтров 0-5 порядков:

$$\frac{\partial V_0^{[P_0^{(\alpha,0)}(\tau,\gamma)]}(j\omega)}{\partial \omega} = -\frac{j c \gamma (\alpha + 1)}{(c \gamma (\alpha + 1) / 2 + j \omega)^2};$$

$$\frac{\partial V_1^{[P_1^{(\alpha,0)}(\tau,\gamma)]}(j\omega)}{\partial \omega} = -\frac{j c \gamma (\alpha + 1) (\alpha + 3)}{(c \gamma (\alpha + 1) / 2 + j \omega)^2} + j c \gamma (\alpha + 2) \times \frac{(\alpha + 3)}{(c \gamma (\alpha + 3) / 2 + j \omega)^2};$$

$$\frac{\partial V_2^{[P_2^{(\alpha,0)}(\tau,\gamma)]}(j\omega)}{\partial \omega} = -\frac{j c \gamma (\alpha + 1) (\alpha + 2) (\alpha + 5)}{2 (c \gamma (\alpha + 1) / 2 + j \omega)^2} + j c \gamma \times \frac{(\alpha + 2) (\alpha + 3) (\alpha + 5)}{2 (c \gamma (\alpha + 3) / 2 + j \omega)^2} - \frac{j c \gamma (\alpha + 3) (\alpha + 4) (\alpha + 5)}{2 (c \gamma (\alpha + 5) / 2 + j \omega)^2};$$

$$\frac{\partial V_3^{[P_3^{(\alpha,0)}(\tau,\gamma)]}(j\omega)}{\partial \omega} = -\frac{j c \gamma (\alpha + 3) (\alpha + 7)}{6 \alpha! (c \gamma (\alpha + 1) / 2 + j \omega)^2} + j c \gamma (\alpha + 7) \times \frac{(\alpha + 4)!}{2 (\alpha + 1)! (c \gamma (\alpha + 3) / 2 + j \omega)^2} - \frac{j c \gamma (\alpha + 5) (\alpha + 7)}{2 (\alpha + 2)! (c \gamma (\alpha + 5) / 2 + j \omega)^2} + \frac{j c \gamma (\alpha + 6) (\alpha + 7)}{6 (\alpha + 3)! (c \gamma (\alpha + 7) / 2 + j \omega)^2};$$

$$\frac{\partial V_4^{[P_4^{(\alpha,0)}(\tau,\gamma)]}(j\omega)}{\partial \omega} = -\frac{j c \gamma (\alpha + 4) (\alpha + 9)}{24 \alpha! (c \gamma (\alpha + 1) / 2 + j \omega)^2} + \frac{j}{6} \times \frac{c \gamma (\alpha + 5) (\alpha + 9)}{(\alpha + 1)! (c \gamma (\alpha + 3) / 2 + j \omega)^2} - \frac{j c \gamma (\alpha + 6) (\alpha + 9)}{4 (\alpha + 2)! (c \gamma (\alpha + 5) / 2 + j \omega)^2} + \frac{j c \gamma (\alpha + 7) (\alpha + 9)}{6 (\alpha + 3)! (c \gamma (\alpha + 7) / 2 + j \omega)^2} - \frac{j c \gamma (\alpha + 8) (\alpha + 9)}{24 (\alpha + 4)! (c \gamma (\alpha + 9) / 2 + j \omega)^2};$$

$$\frac{\partial V_5^{[P_5^{(\alpha,0)}(\tau,\gamma)]}(j\omega)}{\partial \omega} = -\frac{j c \gamma (\alpha + 5) (\alpha + 11)}{120 \alpha! (c \gamma (\alpha + 1) / 2 + j \omega)^2} + \frac{j}{24} \times \frac{c \gamma (\alpha + 6) (\alpha + 11)}{(\alpha + 1)! (c \gamma (\alpha + 3) / 2 + j \omega)^2} - \frac{j c \gamma (\alpha + 7) (\alpha + 11)}{12 (\alpha + 2)! (c \gamma (\alpha + 5) / 2 + j \omega)^2} + \frac{j c \gamma (\alpha + 8) (\alpha + 11)}{12 (\alpha + 3)! (c \gamma (\alpha + 7) / 2 + j \omega)^2} - \frac{j c \gamma (\alpha + 9) (\alpha + 11)}{24 (\alpha + 4)! (c \gamma (\alpha + 9) / 2 + j \omega)^2} + \frac{j c \gamma (\alpha + 10) (\alpha + 11)}{120 (\alpha + 5)! (c \gamma (\alpha + 11) / 2 + j \omega)^2}.$$



Рис. 6.62. Вид производных преобразования Фурье ортогональных фильтров Якоби 2-ого порядка: а)  $\gamma = 1, c = 2, \alpha \in [0; 5], \beta = 0$ ; б)  $\gamma \in [0, 75; 2], c = 2, \alpha = 1, \beta = 0$

$$[6.168] \quad \frac{\partial V_k^{(P_k^{(0,1)}(\tau, \gamma))}(j\omega)}{\partial \omega} = -\frac{8j\gamma^2(k+1)^2}{(2k+3)\gamma + j\omega} \times \\
 \times \sum_{s=0}^k \binom{k}{s} \binom{k+s}{s} (-1)^s \frac{1}{(2s+1)\gamma + j\omega} \times \\
 \times \left( \frac{1}{(2s+1)\gamma + j\omega} + \frac{1}{(2k+3)\gamma + j\omega} \right).$$

Частные случаи для производных преобразования Фурье фильтров 0-5 порядков:

$$\frac{\partial V_0^{(P_0^{(0,1)}(\tau, \gamma))}(j\omega)}{\partial \omega} = -\frac{16j\gamma^2(2\gamma + j\omega)}{(\gamma + j\omega)^2(3\gamma + j\omega)^2}; \\
 \frac{\partial V_1^{(P_1^{(0,1)}(\tau, \gamma))}(j\omega)}{\partial \omega} = -\frac{32j\gamma^2}{(5\gamma + j\omega)} \left( \left( \frac{1}{\gamma + j\omega} + \frac{1}{5\gamma + j\omega} \right) \times \right. \\
 \times \left. \frac{1}{\gamma + j\omega} - \left( \frac{1}{3\gamma + j\omega} + \frac{1}{5\gamma + j\omega} \right) \frac{2}{3\gamma + j\omega} \right); \\
 \frac{\partial V_2^{(P_2^{(0,1)}(\tau, \gamma))}(j\omega)}{\partial \omega} = -\frac{72j\gamma^2}{(7\gamma + j\omega)} \left( \left( \frac{1}{\gamma + j\omega} + \frac{1}{7\gamma + j\omega} \right) \times \right. \\
 \times \left. \frac{1}{\gamma + j\omega} - \left( \frac{1}{3\gamma + j\omega} + \frac{1}{7\gamma + j\omega} \right) \frac{6}{3\gamma + j\omega} + \left( \frac{1}{5\gamma + j\omega} + \right. \right. \\
 \left. \left. + \frac{1}{7\gamma + j\omega} \right) \frac{1}{5\gamma + j\omega} \right); \\
 \frac{\partial V_3^{(P_3^{(0,1)}(\tau, \gamma))}(j\omega)}{\partial \omega} = -\frac{128j\gamma^2}{(9\gamma + j\omega)} \left( \left( \frac{1}{\gamma + j\omega} + \frac{1}{9\gamma + j\omega} \right) \times \right. \\
 \times \left. \frac{1}{\gamma + j\omega} - \left( \frac{1}{3\gamma + j\omega} + \frac{1}{9\gamma + j\omega} \right) \frac{12}{3\gamma + j\omega} + \left( \frac{1}{5\gamma + j\omega} + \right. \right. \\
 \left. \left. + \frac{1}{9\gamma + j\omega} \right) \frac{1}{5\gamma + j\omega} - \left( \frac{1}{7\gamma + j\omega} + \frac{1}{9\gamma + j\omega} \right) \frac{1}{7\gamma + j\omega} \right); \\
 \frac{\partial V_4^{(P_4^{(0,1)}(\tau, \gamma))}(j\omega)}{\partial \omega} = -\frac{200j\gamma^2}{(11\gamma + j\omega)} \left( \left( \frac{1}{\gamma + j\omega} + \frac{1}{11\gamma + j\omega} \right) \times \right.$$

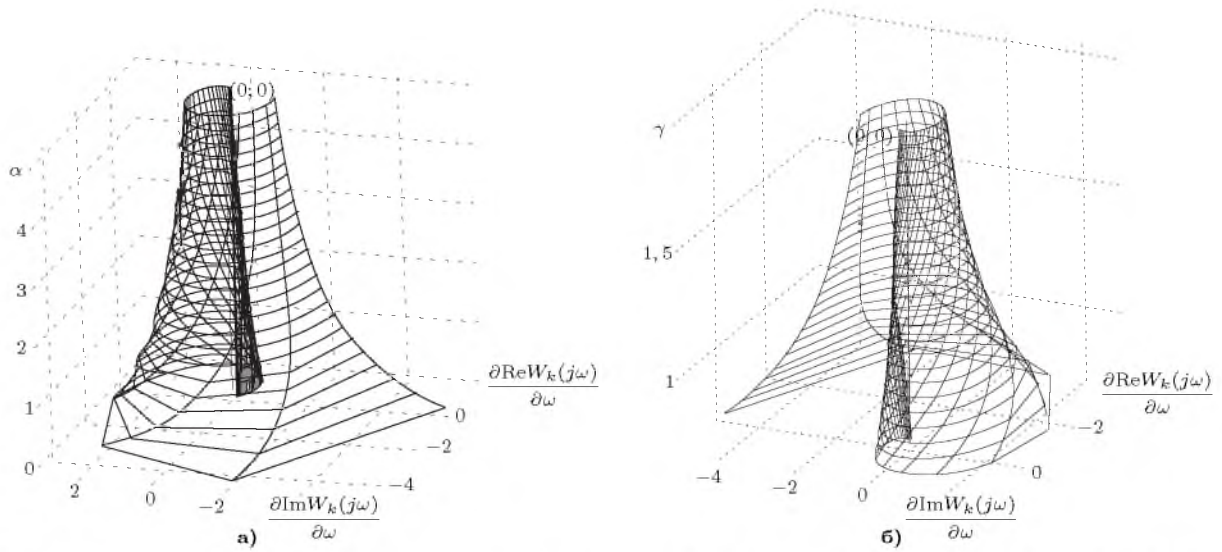
$$\times \frac{1}{\gamma + j\omega} - \left( \frac{1}{3\gamma + j\omega} + \frac{1}{11\gamma + j\omega} \right) \frac{20}{3\gamma + j\omega} + \left( \frac{1}{5\gamma + j\omega} + \right. \\
 \left. + \frac{1}{11\gamma + j\omega} \right) \frac{1}{5\gamma + j\omega} - \left( \frac{1}{7\gamma + j\omega} + \frac{1}{11\gamma + j\omega} \right) \frac{1}{7\gamma + j\omega} + \\
 \left. + \left( \frac{1}{9\gamma + j\omega} + \frac{1}{11\gamma + j\omega} \right) \frac{1}{11\gamma + j\omega} \right); \\
 \frac{\partial V_5^{(P_5^{(0,1)}(\tau, \gamma))}(j\omega)}{\partial \omega} = -\frac{288j\gamma^2}{(13\gamma + j\omega)} \left( \left( \frac{1}{\gamma + j\omega} + \frac{1}{13\gamma + j\omega} \right) \times \right. \\
 \times \left. \frac{1}{\gamma + j\omega} - \left( \frac{1}{3\gamma + j\omega} + \frac{1}{13\gamma + j\omega} \right) \frac{30}{3\gamma + j\omega} + \left( \frac{1}{5\gamma + j\omega} + \right. \right. \\
 \left. \left. + \frac{1}{13\gamma + j\omega} \right) \frac{1}{5\gamma + j\omega} - \left( \frac{1}{7\gamma + j\omega} + \frac{1}{13\gamma + j\omega} \right) \frac{1}{7\gamma + j\omega} + \right. \\
 \left. + \left( \frac{1}{9\gamma + j\omega} + \frac{1}{13\gamma + j\omega} \right) \frac{1}{9\gamma + j\omega} - \left( \frac{1}{11\gamma + j\omega} + \frac{1}{13\gamma + j\omega} \right) \times \right. \\
 \left. \times \frac{1}{11\gamma + j\omega} \right).$$





Рис. 6.63. Вид производных преобразования Фурье ортогональных фильтров Якоби 0-5 порядков;  $\gamma = 1, c = 2, \alpha = 0, \beta = 1$

$$\begin{aligned}
 [6.169] \quad \frac{\partial V_k^{\{P_k^{(0,2)}(\tau, \gamma)\}}(j\omega)}{\partial \omega} &= -\frac{8j\gamma^3(2k+3)}{((2k+3)\gamma + j\omega)} \times \\
 &\times \frac{(k+1)(k+2)}{((2k+5)\gamma + j\omega)} \sum_{s=0}^k \binom{k}{s} \binom{k+s}{s} (-1)^s \times \\
 &\times \frac{1}{(2s+1)\gamma + j\omega} \left( \frac{1}{(2s+1)\gamma + j\omega} + \right. \\
 &\quad \left. + \frac{1}{(2k+3)\gamma + j\omega} + \frac{1}{(2k+5)\gamma + j\omega} \right).
 \end{aligned}$$

Частные случаи для производных преобразования Фурье фильтров 0-5 порядков:

$$\begin{aligned}
 \frac{\partial V_0^{\{P_0^{(0,2)}(\tau, \gamma)\}}(j\omega)}{\partial \omega} &= -\frac{144j\gamma^3(3\gamma + j\omega)}{(\gamma + j\omega)^2(3\gamma + j\omega)^2(5\gamma + j\omega)^2}; \\
 \frac{\partial V_1^{\{P_1^{(0,2)}(\tau, \gamma)\}}(j\omega)}{\partial \omega} &= -\frac{240j\gamma^3}{(5\gamma + j\omega)(7\gamma + j\omega)} \left( \left( \frac{1}{\gamma + j\omega} + \right. \right. \\
 &+ \frac{1}{5\gamma + j\omega} + \frac{1}{7\gamma + j\omega} \Big) \frac{1}{\gamma + j\omega} - \left( \frac{1}{3\gamma + j\omega} + \frac{1}{5\gamma + j\omega} + \right. \\
 &+ \left. \frac{1}{7\gamma + j\omega} \right) \frac{1}{3\gamma + j\omega} \Big); \\
 \frac{\partial V_2^{\{P_2^{(0,2)}(\tau, \gamma)\}}(j\omega)}{\partial \omega} &= -\frac{672j\gamma^3}{(7\gamma + j\omega)(9\gamma + j\omega)} \left( \left( \frac{1}{\gamma + j\omega} + \right. \right. \\
 &+ \frac{1}{7\gamma + j\omega} + \frac{1}{9\gamma + j\omega} \Big) \frac{1}{\gamma + j\omega} - \left( \frac{1}{3\gamma + j\omega} + \frac{1}{7\gamma + j\omega} + \right. \\
 &+ \left. \frac{1}{9\gamma + j\omega} \right) \frac{1}{3\gamma + j\omega} + \left( \frac{1}{5\gamma + j\omega} + \frac{1}{7\gamma + j\omega} + \frac{1}{9\gamma + j\omega} \right) \times \\
 &\times \frac{1}{5\gamma + j\omega} \Big); \\
 \frac{\partial V_3^{\{P_3^{(0,2)}(\tau, \gamma)\}}(j\omega)}{\partial \omega} &= -\frac{1440j\gamma^3}{(9\gamma + j\omega)(11\gamma + j\omega)} \left( \left( \frac{1}{\gamma + j\omega} + \right. \right. \\
 &+ \frac{1}{9\gamma + j\omega} + \frac{1}{11\gamma + j\omega} \Big) \frac{1}{\gamma + j\omega} - \left( \frac{1}{3\gamma + j\omega} + \frac{1}{9\gamma + j\omega} + \right.
 \end{aligned}$$

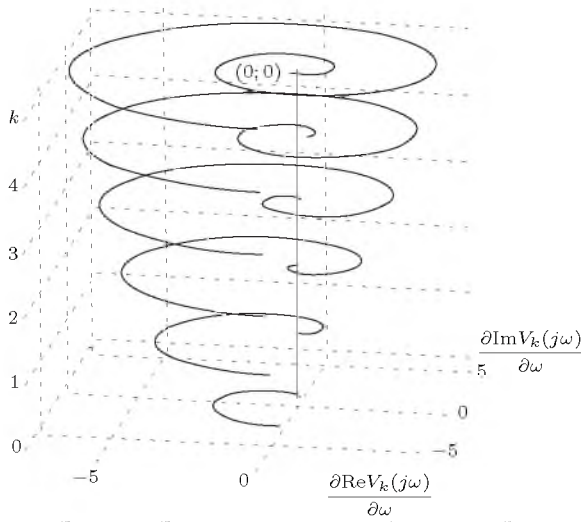
$$\begin{aligned}
 &+ \frac{1}{11\gamma + j\omega} \Big) \frac{12}{3\gamma + j\omega} + \left( \frac{1}{5\gamma + j\omega} + \frac{1}{9\gamma + j\omega} + \frac{1}{11\gamma + j\omega} \right) \times \\
 &\times \frac{1}{5\gamma + j\omega} - \left( \frac{1}{7\gamma + j\omega} + \frac{1}{9\gamma + j\omega} + \frac{1}{11\gamma + j\omega} \right) \frac{1}{7\gamma + j\omega} \Big); \\
 \frac{\partial V_4^{\{P_4^{(0,2)}(\tau, \gamma)\}}(j\omega)}{\partial \omega} &= -\frac{2640j\gamma^3}{(11\gamma + j\omega)(13\gamma + j\omega)} \left( \left( \frac{1}{\gamma + j\omega} + \right. \right. \\
 &+ \frac{1}{11\gamma + j\omega} + \frac{1}{13\gamma + j\omega} \Big) \frac{1}{\gamma + j\omega} - \left( \frac{1}{3\gamma + j\omega} + \frac{1}{11\gamma + j\omega} + \right. \\
 &+ \left. \frac{1}{13\gamma + j\omega} \right) \frac{1}{3\gamma + j\omega} + \left( \frac{1}{5\gamma + j\omega} + \frac{1}{11\gamma + j\omega} + \frac{1}{13\gamma + j\omega} \right) \times \\
 &\times \frac{1}{9\gamma + j\omega} - \left( \frac{1}{7\gamma + j\omega} + \frac{1}{11\gamma + j\omega} + \frac{1}{13\gamma + j\omega} \right) \frac{1}{7\gamma + j\omega} + \\
 &+ \left( \frac{1}{9\gamma + j\omega} + \frac{1}{11\gamma + j\omega} + \frac{1}{13\gamma + j\omega} \right) \frac{1}{11\gamma + j\omega} \Big); \\
 \frac{\partial V_5^{\{P_5^{(0,2)}(\tau, \gamma)\}}(j\omega)}{\partial \omega} &= -\frac{4368j\gamma^3}{(13\gamma + j\omega)(15\gamma + j\omega)} \left( \left( \frac{1}{\gamma + j\omega} + \right. \right. \\
 &+ \frac{1}{13\gamma + j\omega} + \frac{1}{15\gamma + j\omega} \Big) \frac{1}{\gamma + j\omega} - \left( \frac{1}{3\gamma + j\omega} + \frac{1}{13\gamma + j\omega} + \right. \\
 &+ \left. \frac{1}{15\gamma + j\omega} \right) \frac{1}{3\gamma + j\omega} + \left( \frac{1}{5\gamma + j\omega} + \frac{1}{13\gamma + j\omega} + \frac{1}{15\gamma + j\omega} \right) \times \\
 &\times \frac{1}{11\gamma + j\omega} - \left( \frac{1}{7\gamma + j\omega} + \frac{1}{13\gamma + j\omega} + \frac{1}{15\gamma + j\omega} \right) \frac{1}{7\gamma + j\omega} + \\
 &+ \left( \frac{1}{9\gamma + j\omega} + \frac{1}{13\gamma + j\omega} + \frac{1}{15\gamma + j\omega} \right) \frac{1}{9\gamma + j\omega} - \left( \frac{1}{11\gamma + j\omega} + \right. \\
 &+ \left. \frac{1}{13\gamma + j\omega} + \frac{1}{15\gamma + j\omega} \right) \frac{1}{11\gamma + j\omega} \Big).
 \end{aligned}$$



Рис. 6.64. Вид производных преобразования Фурье ортогональных фильтров Якоби 0-5 порядков;  $\gamma = 1, c = 2, \alpha = 0, \beta = 2$

$$\begin{aligned}
[6.170] \quad \frac{\partial V_k^{\{P_k^{(0,\beta)}(\tau,\gamma)\}}(j\omega)}{\partial \omega} &= -\frac{j\gamma^{\beta+1}(k+\beta)!}{k!} \times \\
&\times \frac{(2k+\beta+1)}{\prod_{p=0}^{\beta} (2k+2p+1)\gamma+j\omega} \sum_{s=0}^k \binom{k}{s} \binom{k+s}{s} (-1)^s \times \\
&\times \frac{1}{(2s+1)\gamma+j\omega} \left( \frac{1}{(2s+1)\gamma+j\omega} + \right. \\
&\quad \left. + \sum_{p=0}^{\beta} \frac{1}{(2k+2p+1)\gamma+j\omega} \right).
\end{aligned}$$

Частные случаи для производных преобразования Фурье фильтров 0-5 порядков:

$$\begin{aligned}
\frac{\partial V_0^{\{P_0^{(0,\beta)}(\tau,\gamma)\}}(j\omega)}{\partial \omega} &= -\frac{j\gamma^{\beta+1}(\beta+1)!}{\prod_{p=0}^{\beta} (2p+1)\gamma+j\omega} \left( \frac{1}{\gamma+j\omega} + \right. \\
&+ \left. \sum_{p=0}^{\beta} \frac{1}{(2p+1)\gamma+j\omega} \right) \frac{1}{\gamma+j\omega}; \\
\frac{\partial V_1^{\{P_1^{(0,\beta)}(\tau,\gamma)\}}(j\omega)}{\partial \omega} &= -\frac{j\gamma^{\beta+1}(\beta+1)!(\beta+3)}{\prod_{p=0}^{\beta} (2p+3)\gamma+j\omega} \times \\
&\times \left( \left( \frac{1}{\gamma+j\omega} + \sum_{p=0}^{\beta} \frac{1}{(2p+3)\gamma+j\omega} \right) \frac{1}{\gamma+j\omega} - \right. \\
&- \left. \left( \frac{1}{3\gamma+j\omega} + \sum_{p=0}^{\beta} \frac{1}{(2p+3)\gamma+j\omega} \right) \frac{2}{3\gamma+j\omega} \right); \\
\frac{\partial V_2^{\{P_2^{(0,\beta)}(\tau,\gamma)\}}(j\omega)}{\partial \omega} &= -\frac{j\gamma^{\beta+1}(\beta+2)!(\beta+5)}{2 \prod_{p=0}^{\beta} (2p+5)\gamma+j\omega} \times \\
&\times \left( \left( \frac{1}{\gamma+j\omega} + \sum_{p=0}^{\beta} \frac{1}{(2p+5)\gamma+j\omega} \right) \frac{1}{\gamma+j\omega} - \right. \\
&- \left( \frac{1}{3\gamma+j\omega} + \sum_{p=0}^{\beta} \frac{1}{(2p+5)\gamma+j\omega} \right) \frac{6}{3\gamma+j\omega} + \\
&+ \left. \left( \frac{1}{5\gamma+j\omega} + \sum_{p=0}^{\beta} \frac{1}{(2p+5)\gamma+j\omega} \right) \frac{6}{5\gamma+j\omega} \right); \\
\frac{\partial V_3^{\{P_3^{(0,\beta)}(\tau,\gamma)\}}(j\omega)}{\partial \omega} &= -\frac{j\gamma^{\beta+1}(\beta+3)!(\beta+7)}{6 \prod_{p=0}^{\beta} (2p+7)\gamma+j\omega} \times
\end{aligned}$$

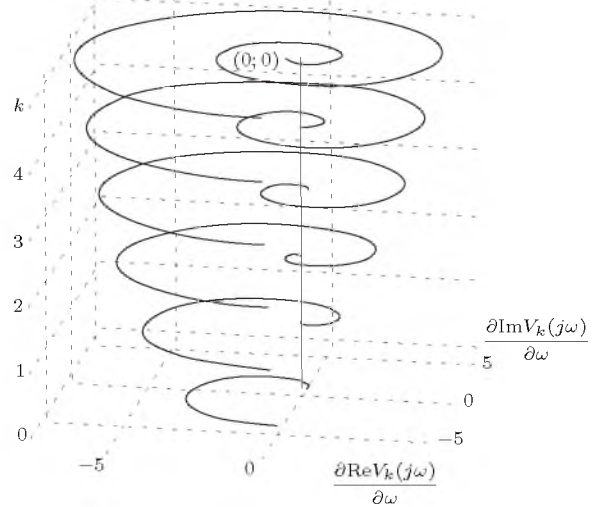
$$\begin{aligned}
&\times \left( \left( \frac{1}{\gamma+j\omega} + \sum_{p=0}^{\beta} \frac{1}{(2p+7)\gamma+j\omega} \right) \frac{1}{\gamma+j\omega} - \right. \\
&- \left( \frac{1}{3\gamma+j\omega} + \sum_{p=0}^{\beta} \frac{1}{(2p+7)\gamma+j\omega} \right) \frac{12}{3\gamma+j\omega} + \\
&+ \left( \frac{1}{5\gamma+j\omega} + \sum_{p=0}^{\beta} \frac{1}{(2p+7)\gamma+j\omega} \right) \frac{30}{5\gamma+j\omega} - \\
&- \left. \left( \frac{1}{7\gamma+j\omega} + \sum_{p=0}^{\beta} \frac{1}{(2p+7)\gamma+j\omega} \right) \frac{20}{7\gamma+j\omega} \right); \\
\frac{\partial V_4^{\{P_4^{(0,\beta)}(\tau,\gamma)\}}(j\omega)}{\partial \omega} &= -\frac{j\gamma^{\beta+1}(\beta+4)!(\beta+9)}{24 \prod_{p=0}^{\beta} (2p+9)\gamma+j\omega} \times \\
&\times \left( \left( \frac{1}{\gamma+j\omega} + \sum_{p=0}^{\beta} \frac{1}{(2p+9)\gamma+j\omega} \right) \frac{1}{\gamma+j\omega} - \right. \\
&- \left( \frac{1}{3\gamma+j\omega} + \sum_{p=0}^{\beta} \frac{1}{(2p+9)\gamma+j\omega} \right) \frac{20}{3\gamma+j\omega} + \\
&+ \left( \frac{1}{5\gamma+j\omega} + \sum_{p=0}^{\beta} \frac{1}{(2p+9)\gamma+j\omega} \right) \frac{90}{5\gamma+j\omega} - \\
&- \left( \frac{1}{7\gamma+j\omega} + \sum_{p=0}^{\beta} \frac{1}{(2p+9)\gamma+j\omega} \right) \frac{140}{7\gamma+j\omega} + \\
&+ \left. \left( \frac{1}{9\gamma+j\omega} + \sum_{p=0}^{\beta} \frac{1}{(2p+9)\gamma+j\omega} \right) \frac{70}{11\gamma+j\omega} \right); \\
\frac{\partial V_5^{\{P_5^{(0,\beta)}(\tau,\gamma)\}}(j\omega)}{\partial \omega} &= -\frac{j\gamma^{\beta+1}(\beta+5)!(\beta+11)}{120 \prod_{p=0}^{\beta} (2p+11)\gamma+j\omega} \times \\
&\times \left( \left( \frac{1}{\gamma+j\omega} + \sum_{p=0}^{\beta} \frac{1}{(2p+11)\gamma+j\omega} \right) \frac{1}{\gamma+j\omega} - \right. \\
&- \left( \frac{1}{3\gamma+j\omega} + \sum_{p=0}^{\beta} \frac{1}{(2p+11)\gamma+j\omega} \right) \frac{30}{3\gamma+j\omega} + \\
&+ \left( \frac{1}{5\gamma+j\omega} + \sum_{p=0}^{\beta} \frac{1}{(2p+11)\gamma+j\omega} \right) \frac{210}{5\gamma+j\omega} - \\
&- \left( \frac{1}{7\gamma+j\omega} + \sum_{p=0}^{\beta} \frac{1}{(2p+11)\gamma+j\omega} \right) \frac{560}{7\gamma+j\omega} + \\
&+ \left( \frac{1}{9\gamma+j\omega} + \sum_{p=0}^{\beta} \frac{1}{(2p+11)\gamma+j\omega} \right) \frac{630}{9\gamma+j\omega} - \\
&- \left. \left( \frac{1}{11\gamma+j\omega} + \sum_{p=0}^{\beta} \frac{1}{(2p+11)\gamma+j\omega} \right) \frac{252}{11\gamma+j\omega} \right).
\end{aligned}$$



Рис. 6.65. Вид производных преобразования Фурье ортогональных фильтров Якоби 2-ого порядка: а)  $\gamma = 1, c = 2, \alpha = 0, \beta \in [0; 5]$ ; б)  $\gamma \in [0, 75; 2], c = 2, \alpha = 0, \beta = 1$



## Глава 7

# Основные и расширенные свойства в частотной области

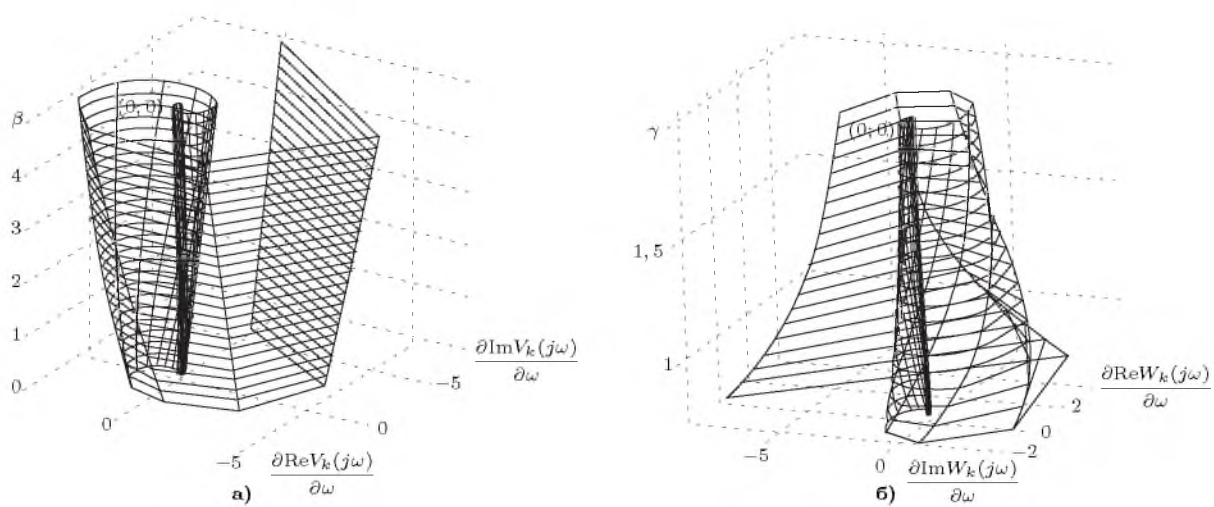
**Определение.**

Ортогональные функции в частотной области, как и во временной, обладают рядом общих свойств [5]

$$\begin{cases} \int_0^{\infty} \operatorname{Re} W_k^{\{\psi_k(\tau, \gamma)\}}(j\omega) d\omega = \frac{\pi}{2} \psi_k(0, \gamma); \\ \int_0^{\infty} \operatorname{Im} W_k^{\{\psi_k(\tau, \gamma)\}}(j\omega) d\omega = 0. \end{cases}$$

Как и во временной, в частотной области были выделены дополнительные свойства [5]

$$\begin{cases} \operatorname{Re} W_k^{\left\{\frac{\partial \psi_k(\tau, \gamma)}{\partial \tau}\right\}}(0) = -\psi_k(0, \gamma); \\ \operatorname{Im} W_k^{\left\{\frac{\partial \psi_k(\tau, \gamma)}{\partial \tau}\right\}}(0) = 0. \end{cases}$$

Таблица 7.1. Основные и расширенные свойства в частотной области

$\psi_k(\tau, \gamma)$	$\int_0^{\infty} \operatorname{Re} W_k^{\{\psi_k(\tau, \gamma)\}}(j\omega) d\omega$	$\int_0^{\infty} \operatorname{Im} W_k^{\{\psi_k(\tau, \gamma)\}}(j\omega) d\omega$	$\operatorname{Re} W_k^{\left\{\frac{\partial \psi_k(\tau, \gamma)}{\partial \tau}\right\}}(0)$	$\operatorname{Im} W_k^{\left\{\frac{\partial \psi_k(\tau, \gamma)}{\partial \tau}\right\}}(0)$
$L_k(\tau, \gamma)$	$\frac{\pi}{2}$	0	-1	0
$L_k^{(1)}(\tau, \gamma)$	$\frac{\pi(k+1)}{2}$	0	$-k-1$	0
$L_k^{(2)}(\tau, \gamma)$	$\frac{\pi(k+1)(k+2)}{4}$	0	$-\frac{(k+1)(k+2)}{2}$	0
$L_k^{(\alpha)}(\tau, \gamma)$	$\frac{\pi}{2} \binom{k+\alpha}{\alpha}$	0	$-\binom{k+\alpha}{\alpha}$	0
$P_k^{(-1/2,0)}(\tau, \gamma)$	$\frac{\pi}{2} (-1)^k$	0	$(-1)^{k+1}$	0
$Leg_k(\tau, \gamma)$	$\frac{\pi}{2} (-1)^k$	0	$(-1)^{k+1}$	0
$P_k^{(1/2,0)}(\tau, \gamma)$	$\frac{\pi}{2} (-1)^k$	0	$(-1)^{k+1}$	0
$P_k^{(1,0)}(\tau, \gamma)$	$\frac{\pi}{2} (-1)^k$	0	$(-1)^{k+1}$	0
$P_k^{(2,0)}(\tau, \gamma)$	$\frac{\pi}{2} (-1)^k$	0	$(-1)^{k+1}$	0
$P_k^{(\alpha,0)}(\tau, \gamma)$	$\frac{\pi}{2} (-1)^k$	0	$(-1)^{k+1}$	0
$P_k^{(0,1)}(\tau, \gamma)$	$\frac{\pi(k+1)}{2} (-1)^k$	0	$(-1)^{k+1}(k+1)$	0
$P_k^{(0,2)}(\tau, \gamma)$	$\frac{\pi(k+1)(k+2)}{4} (-1)^k$	0	$(-1)^{k+1} \frac{(k+1)(k+2)}{2}$	0
$P_k^{(0,\beta)}(\tau, \gamma)$	$(-1)^k \frac{\pi}{2} \binom{k+\beta}{\beta}$	0	$(-1)^{k+1} \binom{k+\beta}{\beta}$	0

## Глава 8

# Основные и расширенные соотношения ортогональности в частотной области

**Определение.**

Для ортогональных функций с единичной весовой функцией в частотной области также справедливы соотношения ортогональности [8, 10, 5]

$$\begin{cases} \int_0^{\infty} \operatorname{Re}W_k^{\{\psi_k(\tau, \gamma)\}}(j\omega) \operatorname{Re}W_n^{\{\psi_n(\tau, \gamma)\}}(j\omega) d\omega = \frac{\pi}{2} \|\psi_k\|^2 \delta_{k,n}; \\ \int_0^{\infty} \operatorname{Im}W_k^{\{\psi_k(\tau, \gamma)\}}(j\omega) \operatorname{Im}W_n^{\{\psi_n(\tau, \gamma)\}}(j\omega) d\omega = \frac{\pi}{2} \|\psi_k\|^2 \delta_{k,n}. \end{cases}$$

Соотношение ортогональности дает возможность записать равенство, связывающее временную и частотную области (теорема Парсеваля) [5, 12]

$$\int_0^{\infty} \left( \operatorname{Re}W_k^{\{\psi_k(\tau, \gamma)\}}(j\omega) \right)^2 d\omega = \frac{\pi}{2} \int_0^{\infty} \left( \psi_k(\tau, \gamma) \right)^2 d\tau.$$

### 8.1 Основные соотношения ортогональности

$$\begin{aligned} \text{[8.1]} \quad & \int_0^{\infty} \operatorname{Re}W_s^{\{L_s(\tau, \gamma)\}}(j\omega) \operatorname{Re}W_k^{\{L_k(\tau, \gamma)\}}(j\omega) d\omega = \\ & = \begin{cases} \frac{\pi}{2\gamma}, & \text{если } k = s; \\ 0, & \text{иначе.} \end{cases} \end{aligned}$$

$$\begin{aligned} \text{[8.2]} \quad & \int_0^{\infty} \operatorname{Im}W_s^{\{L_s(\tau, \gamma)\}}(j\omega) \operatorname{Im}W_k^{\{L_k(\tau, \gamma)\}}(j\omega) d\omega = \\ & = \begin{cases} \frac{\pi}{2\gamma}, & \text{если } k = s; \\ 0, & \text{иначе.} \end{cases} \end{aligned}$$

Матрица значений при  $k = 0..5; s = 0..5$ :

$$\mathcal{M}_{\text{[8.1], [8.2]}} = \frac{\pi}{2\gamma} \begin{pmatrix} 1 & 0 & 0 & 0 & 0 & 0 \\ 0 & 1 & 0 & 0 & 0 & 0 \\ 0 & 0 & 1 & 0 & 0 & 0 \\ 0 & 0 & 0 & 1 & 0 & 0 \\ 0 & 0 & 0 & 0 & 1 & 0 \\ 0 & 0 & 0 & 0 & 0 & 1 \end{pmatrix}.$$



Рис. 8.1. Графическое представление соотношений [8.1], [8.2] при  $k = 0.5, s = 0.5; \gamma = 1$



Рис. 8.2. Графическое представление соотношений [8.4], [??] при  $k = 0.5, s = 0.5; \gamma = 1$

$$\begin{aligned}
 [8.3] \quad & \int_0^\infty \operatorname{Re} W_s^{\{P_s^{(-1/2,0)}(\tau,\gamma)\}}(j\omega) \times \\
 & \times \operatorname{Re} W_k^{\{P_k^{(-1/2,0)}(\tau,\gamma)\}}(j\omega) d\omega = \\
 & = \begin{cases} \frac{\pi}{2(4k+1)\gamma}, & \text{если } k = s; \\ 0, & \text{иначе.} \end{cases}
 \end{aligned}$$

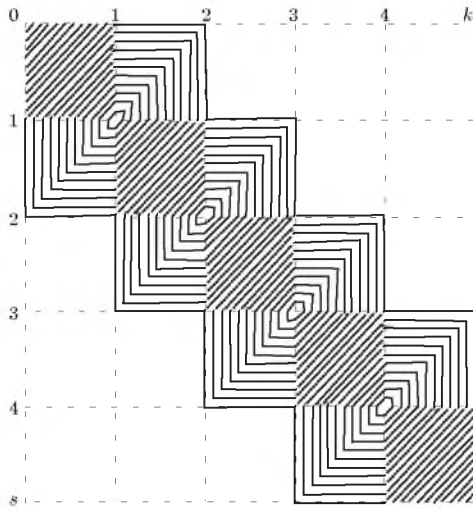
$$\begin{aligned}
 [8.4] \quad & \int_0^\infty \operatorname{Im} W_s^{\{P_s^{(-1/2,0)}(\tau,\gamma)\}}(j\omega) \times \\
 & \times \operatorname{Im} W_k^{\{P_k^{(-1/2,0)}(\tau,\gamma)\}}(j\omega) d\omega = \\
 & = \begin{cases} \frac{\pi}{2(4k+1)\gamma}, & \text{если } k = s; \\ 0, & \text{иначе.} \end{cases}
 \end{aligned}$$

Матрица значений при  $k = 0.5; s = 0.5$ :

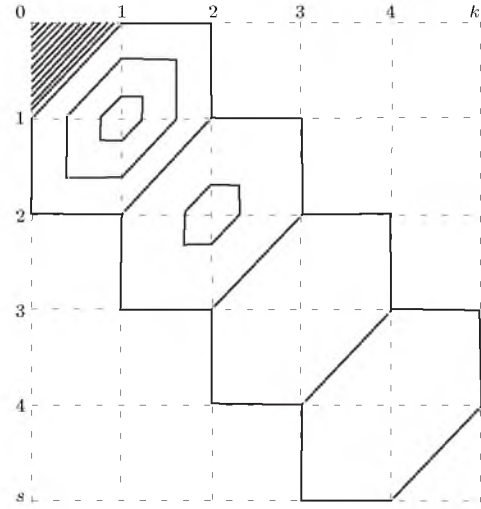
$$\mathcal{M}_{[8.4],[??]} = \frac{\pi}{4\gamma} \begin{pmatrix} 1 & 0 & 0 & 0 & 0 & 0 \\ 0 & 1/5 & 0 & 0 & 0 & 0 \\ 0 & 0 & 1/9 & 0 & 0 & 0 \\ 0 & 0 & 0 & 1/13 & 0 & 0 \\ 0 & 0 & 0 & 0 & 1/17 & 0 \\ 0 & 0 & 0 & 0 & 0 & 1/21 \end{pmatrix}.$$

$$\begin{aligned}
 [8.5] \quad & \int_0^\infty \operatorname{Re} W_s^{\{Leg_s(\tau,\gamma)\}}(j\omega) \operatorname{Re} W_k^{\{Leg_k(\tau,\gamma)\}}(j\omega) d\omega = \\
 & = \begin{cases} \frac{\pi}{4(2k+1)\gamma}, & \text{если } k = s; \\ 0, & \text{иначе.} \end{cases}
 \end{aligned}$$

$$\begin{aligned}
 [8.6] \quad & \int_0^\infty \operatorname{Im} W_s^{\{Leg_s(\tau,\gamma)\}}(j\omega) \operatorname{Im} W_k^{\{Leg_k(\tau,\gamma)\}}(j\omega) d\omega = \\
 & = \begin{cases} \frac{\pi}{4(2k+1)\gamma}, & \text{если } k = s; \\ 0, & \text{иначе.} \end{cases}
 \end{aligned}$$

Матрица значений при  $k = 0.5; s = 0.5$ :

$$\mathcal{M}_{[8.5],[8.6]} = \frac{\pi}{4\gamma} \begin{pmatrix} 1 & 0 & 0 & 0 & 0 & 0 \\ 0 & 1/3 & 0 & 0 & 0 & 0 \\ 0 & 0 & 1/5 & 0 & 0 & 0 \\ 0 & 0 & 0 & 1/7 & 0 & 0 \\ 0 & 0 & 0 & 0 & 1/9 & 0 \\ 0 & 0 & 0 & 0 & 0 & 1/11 \end{pmatrix}.$$





Рис. 8.3. Графическое представление соотношений [8.5], [8.6] при  $k = 0.5, s = 0.5; \gamma = 1$



Рис. 8.4. Графическое представление соотношений [8.7], [8.8] при  $k = 0.5, s = 0.5; \gamma = 1$

$$\begin{aligned}
 [8.7] \quad & \int_0^\infty \operatorname{Re} W_s^{\{P_s^{(1/2,0)}(\tau, \gamma)\}}(j\omega) \times \\
 & \times \operatorname{Re} W_k^{\{P_k^{(1/2,0)}(\tau, \gamma)\}}(j\omega) d\omega = \\
 & = \begin{cases} \frac{\pi}{2(4k+3)\gamma}, & \text{если } k = s; \\ 0, & \text{иначе.} \end{cases}
 \end{aligned}$$

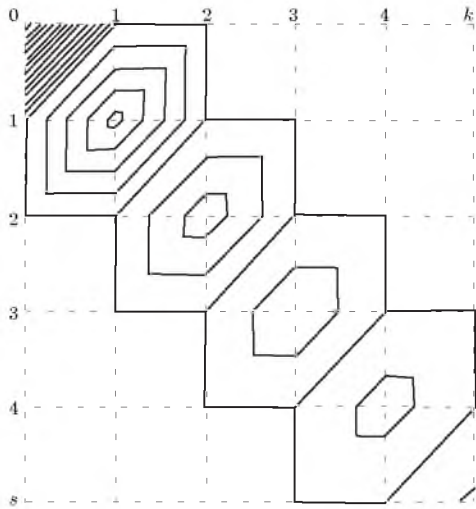
$$\begin{aligned}
 [8.8] \quad & \int_0^\infty \operatorname{Im} W_s^{\{P_s^{(1/2,0)}(\tau, \gamma)\}}(j\omega) \times \\
 & \times \operatorname{Im} W_k^{\{P_k^{(1/2,0)}(\tau, \gamma)\}}(j\omega) d\omega = \\
 & = \begin{cases} \frac{\pi}{2(4k+3)\gamma}, & \text{если } k = s; \\ 0, & \text{иначе.} \end{cases}
 \end{aligned}$$

Матрица значений при  $k = 0.5; s = 0.5$ :

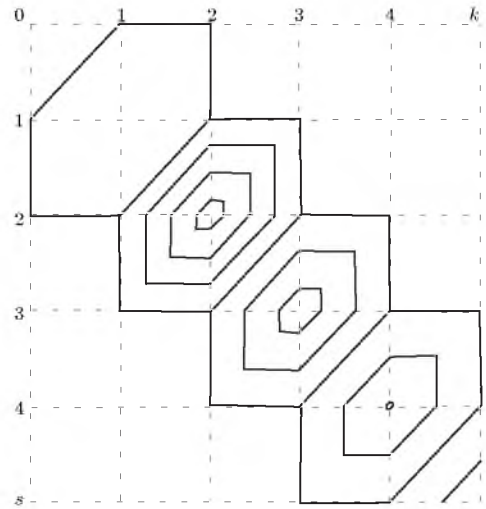
$$\mathcal{M}_{[8.7],[8.8]} = \frac{\pi}{4\gamma} \begin{pmatrix} 1/3 & 0 & 0 & 0 & 0 & 0 \\ 0 & 1/7 & 0 & 0 & 0 & 0 \\ 0 & 0 & 1/11 & 0 & 0 & 0 \\ 0 & 0 & 0 & 1/15 & 0 & 0 \\ 0 & 0 & 0 & 0 & 1/19 & 0 \\ 0 & 0 & 0 & 0 & 0 & 1/23 \end{pmatrix}.$$

$$\begin{aligned}
 [8.9] \quad & \int_0^\infty \operatorname{Re} W_s^{\{P_s^{(1,0)}(\tau, \gamma)\}}(j\omega) \times \\
 & \times \operatorname{Re} W_k^{\{P_k^{(1,0)}(\tau, \gamma)\}}(j\omega) d\omega = \\
 & = \begin{cases} \frac{\pi}{4(k+1)\gamma}, & \text{если } k = s; \\ 0, & \text{иначе.} \end{cases}
 \end{aligned}$$

$$\begin{aligned}
 [8.10] \quad & \int_0^\infty \operatorname{Im} W_s^{\{P_s^{(1,0)}(\tau, \gamma)\}}(j\omega) \times \\
 & \times \operatorname{Im} W_k^{\{P_k^{(1,0)}(\tau, \gamma)\}}(j\omega) d\omega = \\
 & = \begin{cases} \frac{\pi}{4(k+1)\gamma}, & \text{если } k = s; \\ 0, & \text{иначе.} \end{cases}
 \end{aligned}$$

Матрица значений при  $k = 0.5; s = 0.5$ :

$$\mathcal{M}_{[8.9],[8.10]} = \frac{\pi}{4\gamma} \begin{pmatrix} 1 & 0 & 0 & 0 & 0 & 0 \\ 0 & 1/2 & 0 & 0 & 0 & 0 \\ 0 & 0 & 1/3 & 0 & 0 & 0 \\ 0 & 0 & 0 & 1/4 & 0 & 0 \\ 0 & 0 & 0 & 0 & 1/5 & 0 \\ 0 & 0 & 0 & 0 & 0 & 1/6 \end{pmatrix}.$$



Рис. 8.5. Графическое представление соотношений [8.9], [8.10] при  $k = 0.5, s = 0.5; \gamma = 1$



Рис. 8.6. Графическое представление соотношений [8.11], [8.12] при  $k = 0.5, s = 0.5; \gamma = 1$

$$\begin{aligned}
 [8.11] \quad & \int_0^\infty \text{Re}W_s^{\{P_s^{(2,0)}(\tau,\gamma)\}}(j\omega)(\tau,\gamma) \times \\
 & \times \text{Re}W_k^{\{P_k^{(2,0)}(\tau,\gamma)\}}(j\omega)d\omega = \\
 & = \begin{cases} \frac{\pi}{4(2k+3)\gamma}, & \text{если } k = s; \\ 0, & \text{иначе.} \end{cases}
 \end{aligned}$$

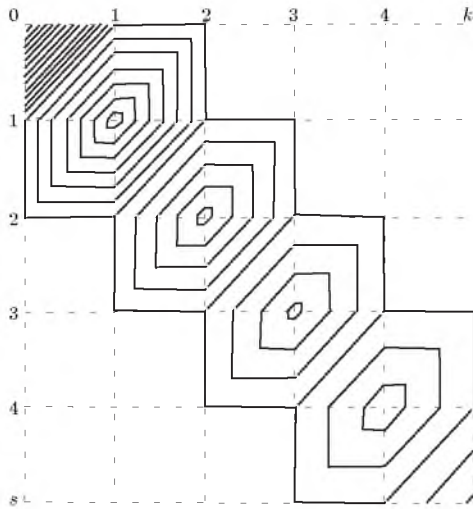
$$\begin{aligned}
 [8.12] \quad & \int_0^\infty \text{Im}W_s^{\{P_s^{(2,0)}(\tau,\gamma)\}}(j\omega)(\tau,\gamma) \times \\
 & \times \text{Im}W_k^{\{P_k^{(2,0)}(\tau,\gamma)\}}(j\omega)d\omega = \\
 & = \begin{cases} \frac{\pi}{4(2k+3)\gamma}, & \text{если } k = s; \\ 0, & \text{иначе.} \end{cases}
 \end{aligned}$$

Матрица значений при  $k = 0.5; s = 0.5;$

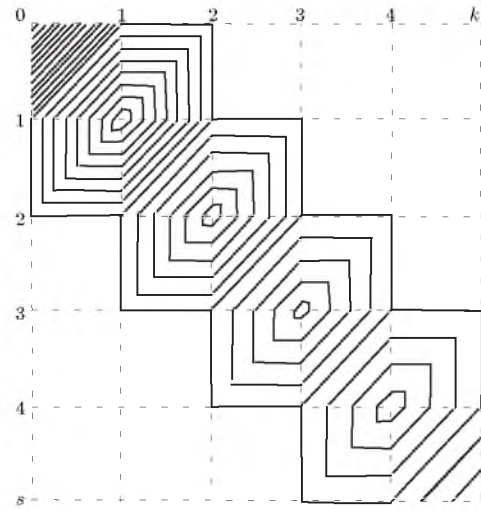
$$\mathcal{M}_{[8.11],[8.12]} = \frac{\pi}{4\gamma} \begin{pmatrix} 1/3 & 0 & 0 & 0 & 0 & 0 \\ 0 & 1/5 & 0 & 0 & 0 & 0 \\ 0 & 0 & 1/7 & 0 & 0 & 0 \\ 0 & 0 & 0 & 1/9 & 0 & 0 \\ 0 & 0 & 0 & 0 & 1/11 & 0 \\ 0 & 0 & 0 & 0 & 0 & 1/13 \end{pmatrix}$$

$$\begin{aligned}
 [8.13] \quad & \int_0^\infty \text{Re}W_s^{\{P_s^{(\alpha,0)}(\tau,\gamma)\}}(j\omega)(\tau,\gamma) \times \\
 & \times \text{Re}W_k^{\{P_k^{(\alpha,0)}(\tau,\gamma)\}}(j\omega)d\omega = \\
 & = \begin{cases} \frac{\pi}{2c(2k+\alpha+1)\gamma}, & \text{если } k = s; \\ 0, & \text{иначе.} \end{cases}
 \end{aligned}$$

$$\begin{aligned}
 [8.14] \quad & \int_0^\infty \text{Im}W_s^{\{P_s^{(\alpha,0)}(\tau,\gamma)\}}(j\omega)(\tau,\gamma) \times \\
 & \times \text{Im}W_k^{\{P_k^{(\alpha,0)}(\tau,\gamma)\}}(j\omega)d\omega = \\
 & = \begin{cases} \frac{\pi}{2c(2k+\alpha+1)\gamma}, & \text{если } k = s; \\ 0, & \text{иначе.} \end{cases}
 \end{aligned}$$

Матрица значений при  $k = 0.5; s = 0.5;$

$$\mathcal{M}_{[8.13],[8.14]} = \frac{\pi}{2c\gamma} \times \begin{pmatrix} \frac{1}{(\alpha+1)} & 0 & 0 & 0 & 0 & 0 \\ 0 & \frac{1}{(\alpha+3)} & 0 & 0 & 0 & 0 \\ 0 & 0 & \frac{1}{(\alpha+5)} & 0 & 0 & 0 \\ 0 & 0 & 0 & \frac{1}{(\alpha+7)} & 0 & 0 \\ 0 & 0 & 0 & 0 & \frac{1}{(\alpha+9)} & 0 \\ 0 & 0 & 0 & 0 & 0 & \frac{1}{(\alpha+11)} \end{pmatrix}$$



Рис. 8.7. Графическое представление соотношения [8.13], [8.14] при  $k = 0.5$  и  $k = s$ : а)  $\gamma = 1, c = 2, \alpha \in [0; 5]$ ; б)  $\gamma \in [0, 5; 5, 5], c = 2, \alpha = 1$

### 8.2 Расширенные соотношения ортогональности

$$[8.15] \int_0^\infty \frac{\partial \text{Im} W_s^{(L_s(\tau, \gamma))}(j\omega)}{\partial \omega} \text{Re} W_k^{(L_k(\tau, \gamma))}(j\omega) d\omega = \begin{cases} \frac{(k+1)\pi}{2\gamma^2}, & \text{если } k = s-1; \\ -\frac{(2k+1)\pi}{2\gamma^2}, & \text{если } k = s; \\ \frac{k\pi}{2\gamma^2}, & \text{если } k = s+1; \\ 0, & \text{иначе.} \end{cases}$$

Матрица значений при  $k = 0.5; s = 0.5$ :

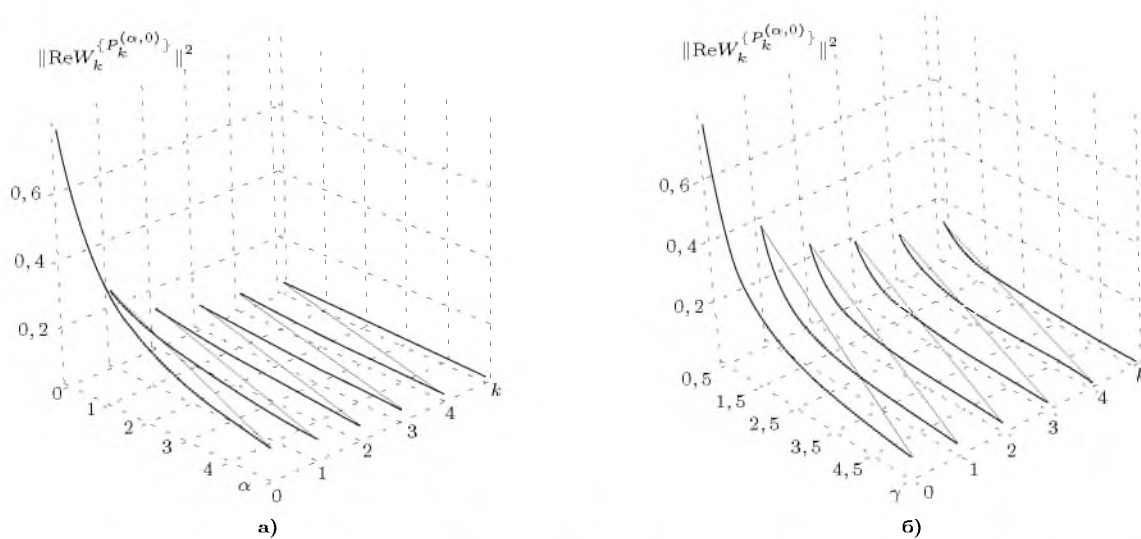
$$\mathcal{M}_{[8.15]} = \frac{\pi}{2\gamma^2} \begin{pmatrix} -1 & 1 & 0 & 0 & 0 & 0 \\ 1 & -3 & 2 & 0 & 0 & 0 \\ 0 & 2 & -5 & 3 & 0 & 0 \\ 0 & 0 & 3 & -7 & 4 & 0 \\ 0 & 0 & 0 & 4 & -9 & 5 \\ 0 & 0 & 0 & 0 & 5 & -11 \end{pmatrix}$$

$$[8.16] \int_0^\infty \frac{\partial \text{Re} W_s^{(L_s(\tau, \gamma))}(j\omega)}{\partial \omega} \text{Im} W_k^{(L_k(\tau, \gamma))}(j\omega) d\omega = \begin{cases} -\frac{(k+1)\pi}{2\gamma^2}, & \text{если } k = s-1; \\ \frac{(2k+1)\pi}{2\gamma^2}, & \text{если } k = s; \\ -\frac{k\pi}{2\gamma^2}, & \text{если } k = s+1; \\ 0, & \text{иначе.} \end{cases}$$

Матрица значений при  $k = 0.5; s = 0.5$ :



Рис. 8.8. Графическое представление соотношений [8.15], [8.16] при  $k = 0.5, s = 0.5; \gamma = 1$

$$[8.17] \int_0^\infty \text{Re} W_s \left\{ \frac{\partial L_s(\tau, \gamma)}{\partial \tau} \right\} (j\omega) \text{Re} W_k^{(L_k(\tau, \gamma))}(j\omega) d\omega = \begin{cases} -\frac{\pi}{2}, & \text{если } k > s; \\ -\frac{\pi}{4}, & \text{если } k = s; \\ 0, & \text{иначе.} \end{cases}$$

$$[8.18] \int_0^{\infty} \text{Im}W_s^{\left\{\frac{\partial L_s(\tau,\gamma)}{\partial \tau}\right\}}(j\omega) \text{Im}W_k^{\{L_k(\tau,\gamma)\}}(j\omega) d\omega = \begin{cases} -\frac{\pi}{2}, & \text{если } k > s; \\ -\frac{\pi}{4}, & \text{если } k = s; \\ 0, & \text{иначе.} \end{cases}$$

Матрица значений при  $k = 0.5; s = 0.5$ :

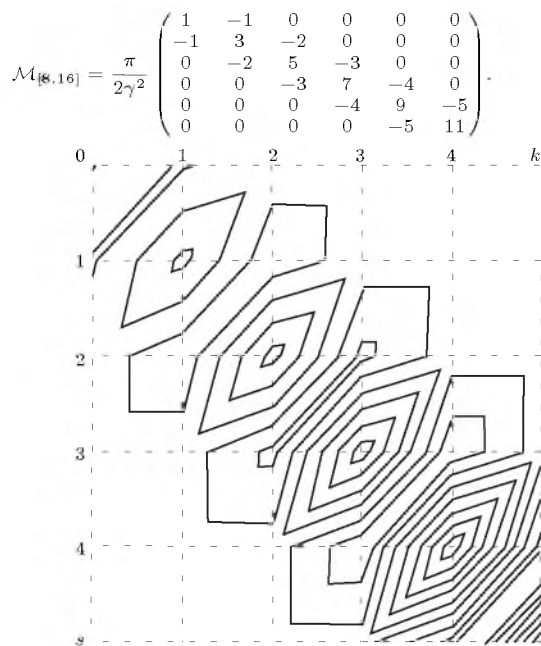

Рис. 8.9. Графическое представление соотношений [8.17], [8.18] при  $k = 0.5, s = 0.5; \gamma = 1$

$$[8.20] \int_0^{\infty} \text{Re}W_s^{\left\{\frac{\partial L_s(\tau,\gamma)}{\partial \tau}\right\}}(j\omega) \frac{\partial \text{Im}W_k^{\{L_k(\tau,\gamma)\}}(j\omega)}{\partial \omega} d\omega = \begin{cases} \frac{(k+1)\pi}{4\gamma}, & \text{если } k = s-1; \\ \frac{\pi}{4\gamma}, & \text{если } k = s; \\ -\frac{k\pi}{4\gamma}, & \text{если } k = s+1; \\ 0, & \text{иначе.} \end{cases}$$

Матрица значений при  $k = 0.5; s = 0.5$ :

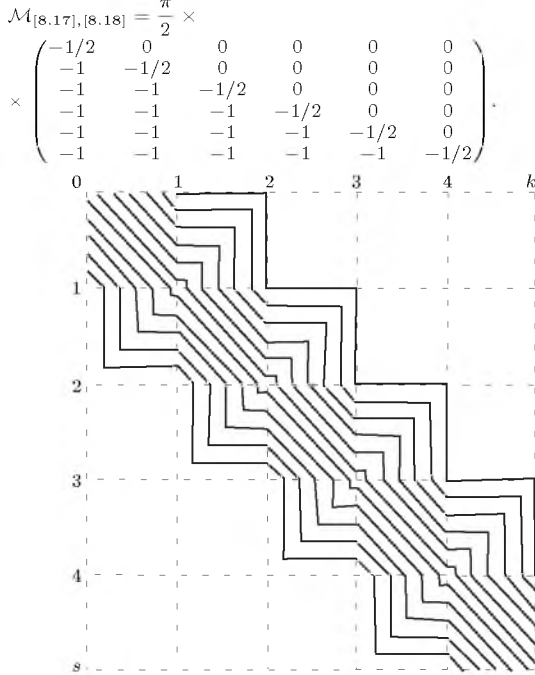

Рис. 8.10. Графическое представление соотношений [8.19], [8.20] при  $k = 0.5, s = 0.5; \gamma = 1$

$$[8.19] \int_0^{\infty} \text{Im}W_s^{\left\{\frac{\partial L_s(\tau,\gamma)}{\partial \tau}\right\}}(j\omega) \frac{\partial \text{Re}W_k^{\{L_k(\tau,\gamma)\}}(j\omega)}{\partial \omega} d\omega = \begin{cases} -\frac{(k+1)\pi}{4\gamma}, & \text{если } k = s-1; \\ -\frac{\pi}{4\gamma}, & \text{если } k = s; \\ \frac{k\pi}{4\gamma}, & \text{если } k = s+1; \\ 0, & \text{иначе.} \end{cases}$$

Матрица значений при  $k = 0.5; s = 0.5$ :

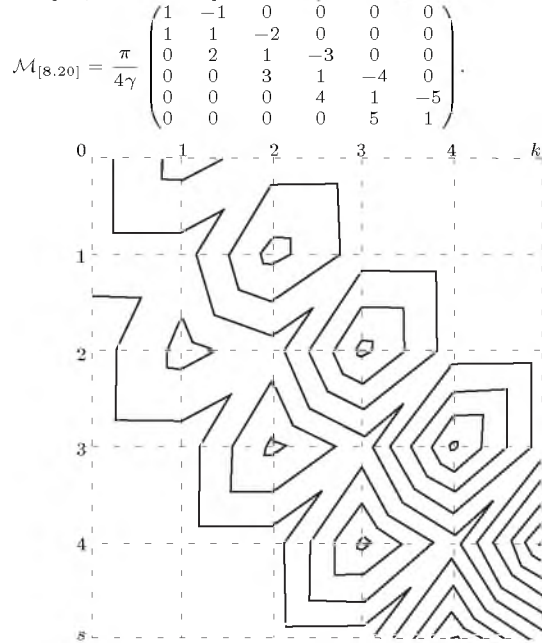
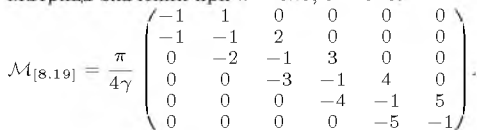

$$[8.21] \int_0^{\infty} \text{Re}W_s^{\left\{\frac{\partial L_s(\tau,\gamma)}{\partial \tau}\right\}}(j\omega) \text{Re}W_k^{\left\{\frac{\partial L_k(\tau,\gamma)}{\partial \tau}\right\}}(j\omega) d\omega - \frac{(2k+1)\gamma\pi}{4} = \begin{cases} -\frac{(k-s)\gamma\pi}{2}, & \text{если } k > s; \\ -\frac{\gamma\pi}{8}, & \text{если } k = s; \\ 0, & \text{иначе.} \end{cases}$$

$$[8.22] \int_0^{\infty} \text{Im}W_s^{\left\{\frac{\partial L_s(\tau,\gamma)}{\partial \tau}\right\}}(j\omega) \text{Im}W_k^{\left\{\frac{\partial L_k(\tau,\gamma)}{\partial \tau}\right\}}(j\omega) d\omega - \frac{(2k+1)\gamma\pi}{4} = \begin{cases} -\frac{(k-s)\gamma\pi}{2}, & \text{если } k > s; \\ -\frac{\gamma\pi}{8}, & \text{если } k = s; \\ 0, & \text{иначе.} \end{cases}$$

Матрица значений при  $k = 0.5; s = 0.5$ :

$$\mathcal{M}_{[8.21],[8.22]} = \frac{\pi\gamma}{2} \times$$



Рис. 8.11. Графическое представление соотношений [8.21], [8.22] при  $k = 0.5, s = 0.5; \gamma = 1$

$$[8.23] \int_0^{\infty} \text{Im}W_s^{L_s(\tau,\gamma)}(j\omega)\text{Re}W_k^{L_k(\tau,\gamma)}(j\omega)d\omega = \begin{cases} \frac{1}{s-k}, & \text{если } (k+1) \bmod 2 \neq 0; \\ \frac{1}{2k+1}, & \text{если } k = s; \\ -\frac{1}{k+s+1}, & \text{иначе.} \end{cases}$$

Матрица значений при  $k = 0.5; s = 0.5$ :

$$\mathcal{M}_{[8.23]} = \begin{pmatrix} -1 & -1 & -1/3 & -1/3 & -1/5 & -1/5 \\ 1 & -1/3 & -1 & -1/5 & -1/3 & -1/7 \\ -1/3 & 1 & -1/5 & -1 & -1/7 & -1/3 \\ 1/3 & -1/5 & 1 & -1/7 & -1 & -1/9 \\ -1/5 & 1/3 & -1/7 & 1 & -1/9 & -1 \\ 1/5 & -1/7 & 1/3 & -1/9 & 1 & -1/11 \end{pmatrix}$$

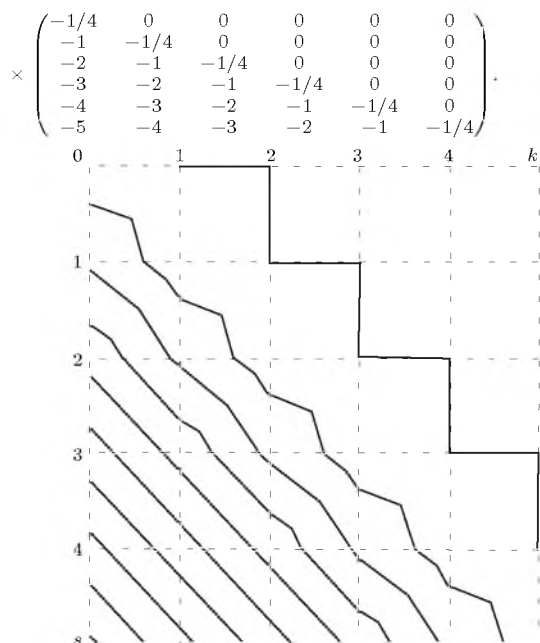
$$[8.24] \int_0^{\infty} \text{Re}W_s^{L_s(\tau,\gamma)}(j\omega)\text{Im}W_k^{L_k(\tau,\gamma)}(j\omega)d\omega = \begin{cases} -\frac{1}{s-k}, & \text{если } (k+1) \bmod 2 \neq 0; \\ \frac{1}{2k+1}, & \text{если } k = s; \\ \frac{1}{k+s+1}, & \text{иначе.} \end{cases}$$

Матрица значений при  $k = 0.5; s = 0.5$ :

$$\mathcal{M}_{[8.24]} = \begin{pmatrix} -1 & 1 & -1/3 & 1/3 & -1/5 & 1/5 \\ -1 & -1/3 & 1 & -1/5 & 1/3 & -1/7 \\ -1/3 & -1 & -1/5 & 1 & -1/7 & 1/3 \\ -1/3 & -1/5 & -1 & -1/7 & 1 & -1/9 \\ -1/5 & 1/3 & -1/7 & 1 & -1/9 & 1 \\ -1/5 & -1/7 & 1/3 & -1/9 & 1 & -1/11 \end{pmatrix}$$



Рис. 8.12. Графическое представление соотношений [8.23], [8.24] при  $k = 0.5, s = 0.5; \gamma = 1$

$$[8.25] \int_0^{\infty} \text{Re}W_s^{L_s^{(1)}(\tau,\gamma)}(j\omega)\text{Re}W_k^{L_k^{(1)}(\tau,\gamma)}(j\omega)d\omega - \frac{\pi(k+1)}{2\gamma} = \begin{cases} -\frac{(k-s)\gamma\pi}{2}, & \text{если } k > s; \\ 0, & \text{иначе.} \end{cases}$$

$$[8.26] \int_0^{\infty} \text{Im}W_s^{L_s^{(1)}(\tau,\gamma)}(j\omega)\text{Im}W_k^{L_k^{(1)}(\tau,\gamma)}(j\omega)d\omega - \frac{\pi(k+1)}{2\gamma} = \begin{cases} -\frac{(k-s)\gamma\pi}{2}, & \text{если } k > s; \\ 0, & \text{иначе.} \end{cases}$$

Матрица значений при  $k = 0.5; s = 0.5$ :

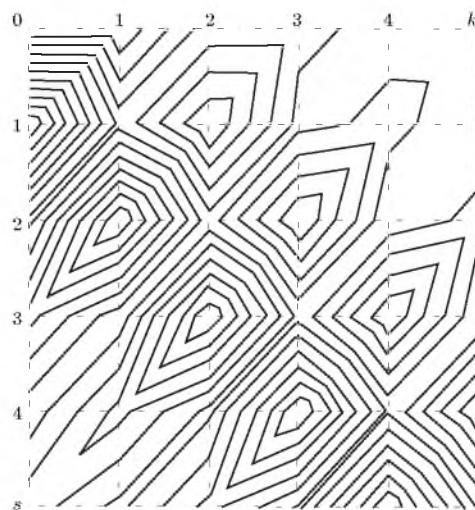
$$\mathcal{M}_{[8.25],[8.26]} = \frac{\pi}{2\gamma} \times \begin{pmatrix} 0 & 0 & 0 & 0 & 0 & 0 \\ -1 & 0 & 0 & 0 & 0 & 0 \\ -2 & -1 & 0 & 0 & 0 & 0 \\ -3 & -2 & -1 & 0 & 0 & 0 \\ -4 & -3 & -2 & -1 & 0 & 0 \\ -5 & -4 & -3 & -2 & -1 & 0 \end{pmatrix}$$



Рис. 8.13. Графическое представление соотношений [8.25], [8.26] при  $k = 0.5, s = 0.5; \gamma = 1$



Рис. 8.14. Графическое представление соотношений [8.27], [8.28] при  $k = 0.5, s = 0.5; \gamma = 1$

$$\begin{aligned}
 [8.27] \quad & \int_0^\infty \text{Re}W_s \left\{ \frac{\partial P_s^{(-1/2,0)}(\tau,\gamma)}{\partial \tau} \right\} (j\omega) \times \\
 & \times \text{Re}W_k \left\{ P_k^{(-1/2,0)}(\tau,\gamma) \right\} (j\omega) d\omega = \\
 & = \begin{cases} -\frac{\pi(-1)^{k+s}}{2}, & \text{если } k > s; \\ -\frac{\pi}{4}, & \text{если } k = s; \\ 0, & \text{иначе.} \end{cases}
 \end{aligned}$$

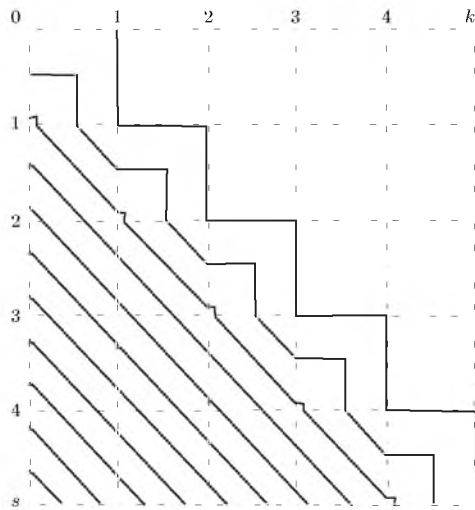
$$\begin{aligned}
 [8.28] \quad & \int_0^\infty \text{Im}W_s \left\{ \frac{\partial P_s^{(-1/2,0)}(\tau,\gamma)}{\partial \tau} \right\} (j\omega) \times \\
 & \times \text{Im}W_k \left\{ P_k^{(-1/2,0)}(\tau,\gamma) \right\} (j\omega) d\omega = \\
 & = \begin{cases} -\frac{\pi(-1)^{k+s}}{2}, & \text{если } k > s; \\ -\frac{\pi}{4}, & \text{если } k = s; \\ 0, & \text{иначе.} \end{cases}
 \end{aligned}$$

Матрица значений при  $k = 0.5; s = 0.5$ :

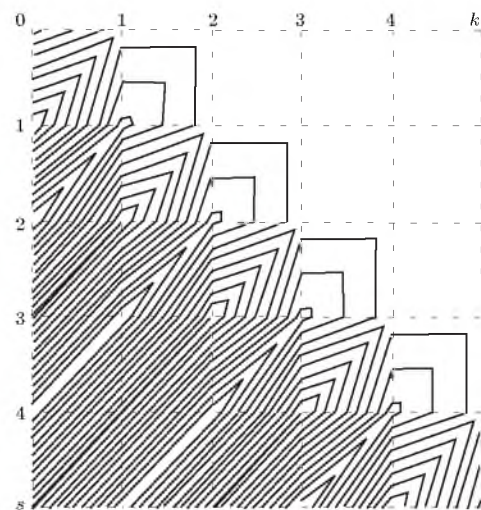
$$\mathcal{M}_{[8.27],[8.28]} = \frac{\pi}{2} \times \begin{pmatrix} -1/2 & 0 & 0 & 0 & 0 & 0 \\ 1 & -1/2 & 0 & 0 & 0 & 0 \\ -1 & 1 & -1/2 & 0 & 0 & 0 \\ 1 & -1 & 1 & -1/2 & 0 & 0 \\ -1 & 1 & -1 & 1 & -1/2 & 0 \\ 1 & -1 & 1 & -1 & 1 & -1/2 \end{pmatrix}$$

$$\begin{aligned}
 [8.29] \quad & \int_0^\infty \text{Re}W_s \left\{ \frac{\partial \text{Leg}_s(\tau,\gamma)}{\partial \tau} \right\} (j\omega) \times \\
 & \times \text{Re}W_k \left\{ \text{Leg}_k(\tau,\gamma) \right\} (j\omega) d\omega = \\
 & = \begin{cases} -\frac{\pi(-1)^{k+s}}{2}, & \text{если } k > s; \\ -\frac{\pi}{4}, & \text{если } k = s; \\ 0, & \text{иначе.} \end{cases}
 \end{aligned}$$

$$\begin{aligned}
 [8.30] \quad & \int_0^\infty \text{Im}W_s \left\{ \frac{\partial \text{Leg}_s(\tau,\gamma)}{\partial \tau} \right\} (j\omega) \times \\
 & \times \text{Im}W_k \left\{ \text{Leg}_k(\tau,\gamma) \right\} (j\omega) d\omega = \\
 & = \begin{cases} -\frac{\pi(-1)^{k+s}}{2}, & \text{если } k > s; \\ -\frac{\pi}{4}, & \text{если } k = s; \\ 0, & \text{иначе.} \end{cases}
 \end{aligned}$$

Матрица значений при  $k = 0.5; s = 0.5$ :

$$\mathcal{M}_{[8.29],[8.30]} = \frac{\pi}{2} \times \begin{pmatrix} -1/2 & 0 & 0 & 0 & 0 & 0 \\ 1 & -1/2 & 0 & 0 & 0 & 0 \\ -1 & 1 & -1/2 & 0 & 0 & 0 \\ 1 & -1 & 1 & -1/2 & 0 & 0 \\ -1 & 1 & -1 & 1 & -1/2 & 0 \\ 1 & -1 & 1 & -1 & 1 & -1/2 \end{pmatrix}$$



Рис. 8.15. Графическое представление соотношений [8.29], [8.30] при  $k = 0.5, s = 0.5; \gamma = 1$



Рис. 8.16. Графическое представление соотношений [8.31], [8.32] при  $k = 0.5, s = 0.5; \gamma = 1$

$$\begin{aligned}
 [8.31] \quad & \int_0^\infty \operatorname{Re} W_s^{\left\{ \frac{\partial P_s^{(1/2,0)}(\tau, \gamma)}{\partial \tau} \right\}}(j\omega) \times \\
 & \times \operatorname{Re} W_k^{\{P_k^{(1/2,0)}(\tau, \gamma)\}}(j\omega) d\omega = \\
 & = \begin{cases} -\frac{\pi(-1)^{k+s}}{2}, & \text{если } k > s; \\ -\frac{\pi}{4}, & \text{если } k = s; \\ 0, & \text{иначе.} \end{cases}
 \end{aligned}$$

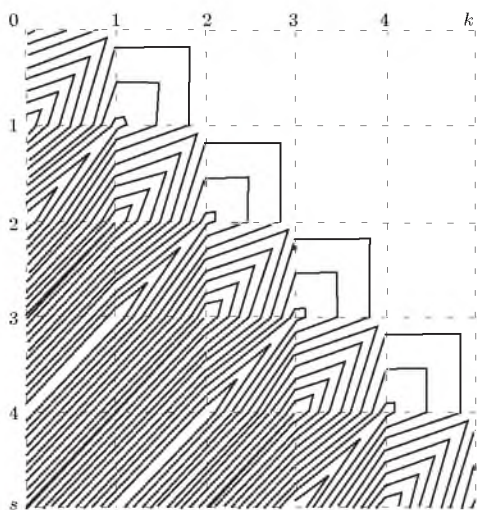
$$\begin{aligned}
 [8.33] \quad & \int_0^\infty \operatorname{Re} W_s^{\left\{ \frac{\partial P_s^{(1,0)}(\tau, \gamma)}{\partial \tau} \right\}}(j\omega) \times \\
 & \times \operatorname{Re} W_k^{\{P_k^{(1,0)}(\tau, \gamma)\}}(j\omega) d\omega = \\
 & = \begin{cases} -\frac{\pi(-1)^{k+s}}{2}, & \text{если } k > s; \\ -\frac{\pi}{4}, & \text{если } k = s; \\ 0, & \text{иначе.} \end{cases}
 \end{aligned}$$

$$\begin{aligned}
 [8.32] \quad & \int_0^\infty \operatorname{Im} W_s^{\left\{ \frac{\partial P_s^{(1/2,0)}(\tau, \gamma)}{\partial \tau} \right\}}(j\omega) \times \\
 & \times \operatorname{Im} W_k^{\{P_k^{(1/2,0)}(\tau, \gamma)\}}(j\omega) d\omega = \\
 & = \begin{cases} -\frac{\pi(-1)^{k+s}}{2}, & \text{если } k > s; \\ -\frac{\pi}{4}, & \text{если } k = s; \\ 0, & \text{иначе.} \end{cases}
 \end{aligned}$$

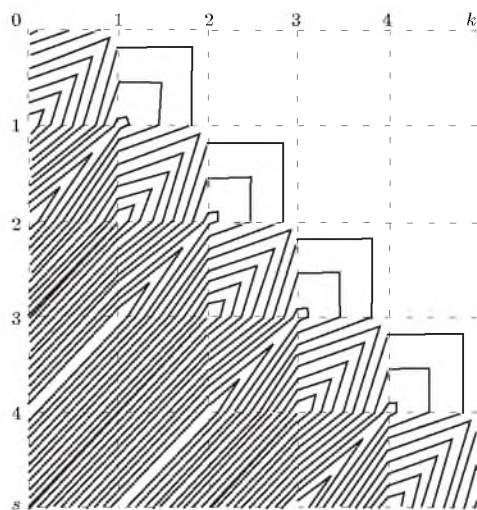
$$\begin{aligned}
 [8.34] \quad & \int_0^\infty \operatorname{Im} W_s^{\left\{ \frac{\partial P_s^{(1,0)}(\tau, \gamma)}{\partial \tau} \right\}}(j\omega) \times \\
 & \times \operatorname{Im} W_k^{\{P_k^{(1,0)}(\tau, \gamma)\}}(j\omega) d\omega = \\
 & = \begin{cases} -\frac{\pi(-1)^{k+s}}{2}, & \text{если } k > s; \\ -\frac{\pi}{4}, & \text{если } k = s; \\ 0, & \text{иначе.} \end{cases}
 \end{aligned}$$

Матрица значений при  $k = 0.5; s = 0.5$ :

$$\begin{aligned}
 \mathcal{M}_{[8.31],[8.32]} &= \frac{\pi}{2} \times \\
 & \times \begin{pmatrix} -1/2 & 0 & 0 & 0 & 0 & 0 \\ 1 & -1/2 & 0 & 0 & 0 & 0 \\ -1 & 1 & -1/2 & 0 & 0 & 0 \\ 1 & -1 & 1 & -1/2 & 0 & 0 \\ -1 & 1 & -1 & 1 & -1/2 & 0 \\ 1 & -1 & 1 & -1 & 1 & -1/2 \end{pmatrix},
 \end{aligned}$$

Матрица значений при  $k = 0.5; s = 0.5$ :

$$\begin{aligned}
 \mathcal{M}_{[8.33],[8.34]} &= \frac{\pi}{2} \times \\
 & \times \begin{pmatrix} -1/2 & 0 & 0 & 0 & 0 & 0 \\ 1 & -1/2 & 0 & 0 & 0 & 0 \\ -1 & 1 & -1/2 & 0 & 0 & 0 \\ 1 & -1 & 1 & -1/2 & 0 & 0 \\ -1 & 1 & -1 & 1 & -1/2 & 0 \\ 1 & -1 & 1 & -1 & 1 & -1/2 \end{pmatrix},
 \end{aligned}$$



Рис. 8.17. Графическое представление соотношений [8.33], [8.34] при  $k = 0..5$ ,  $s = 0..5$ ;  $\gamma = 1$

$$\begin{aligned}
 [8.35] \quad & \int_0^\infty \operatorname{Re} W_s \left\{ \frac{\partial P_s^{(2,0)}(\tau, \gamma)}{\partial \tau} \right\} (j\omega) \times \\
 & \times \operatorname{Re} W_k \{ P_k^{(2,0)}(\tau, \gamma) \} (j\omega) d\omega = \\
 & = \begin{cases} -\frac{\pi(-1)^{k+s}}{2}, & \text{если } k > s; \\ -\frac{\pi}{4}, & \text{если } k = s; \\ 0, & \text{иначе.} \end{cases}
 \end{aligned}$$

$$\begin{aligned}
 [8.36] \quad & \int_0^\infty \operatorname{Im} W_s \left\{ \frac{\partial P_s^{(2,0)}(\tau, \gamma)}{\partial \tau} \right\} (j\omega) \times \\
 & \times \operatorname{Im} W_k \{ P_k^{(2,0)}(\tau, \gamma) \} (j\omega) d\omega = \\
 & = \begin{cases} -\frac{\pi(-1)^{k+s}}{2}, & \text{если } k > s; \\ -\frac{\pi}{4}, & \text{если } k = s; \\ 0, & \text{иначе.} \end{cases}
 \end{aligned}$$

Матрица значений при  $k = 0..5$ ;  $s = 0..5$ :  
 $\mathcal{M}_{[8.35],[8.36]} = \frac{\pi}{2} \times$



Рис. 8.18. Графическое представление соотношений [8.35], [8.36] при  $k = 0..5$ ,  $s = 0..5$ ;  $\gamma = 1$

$$\begin{aligned}
 [8.37] \quad & \int_0^\infty \operatorname{Re} W_s \left\{ \frac{\partial P_s^{(\alpha,0)}(\tau, \gamma)}{\partial \tau} \right\} (j\omega) \times \\
 & \times \operatorname{Re} W_k \{ P_k^{(\alpha,0)}(\tau, \gamma) \} (j\omega) d\omega = \\
 & = \begin{cases} -\frac{\pi(-1)^{k+s}}{2}, & \text{если } k > s; \\ -\frac{\pi}{4}, & \text{если } k = s; \\ 0, & \text{иначе.} \end{cases}
 \end{aligned}$$

$$\begin{aligned}
 [8.38] \quad & \int_0^\infty \operatorname{Im} W_s \left\{ \frac{\partial P_s^{(\alpha,0)}(\tau, \gamma)}{\partial \tau} \right\} (j\omega) \times \\
 & \times \operatorname{Im} W_k \{ P_k^{(\alpha,0)}(\tau, \gamma) \} (j\omega) d\omega = \\
 & = \begin{cases} -\frac{\pi(-1)^{k+s}}{2}, & \text{если } k > s; \\ -\frac{\pi}{4}, & \text{если } k = s; \\ 0, & \text{иначе.} \end{cases}
 \end{aligned}$$

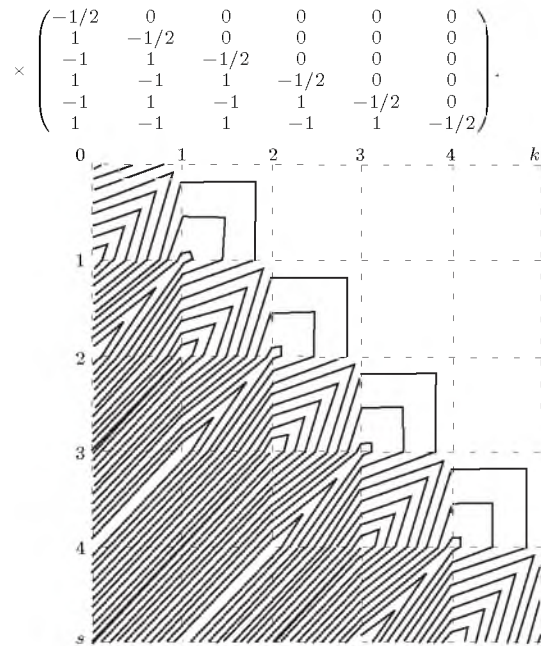

## Глава 9

# Рекуррентные соотношения

**Определение.**

Для ортогональных многочленов Якоби справедливо следующее рекуррентное соотношение [13, 15]:

$$\begin{aligned} & 2(k+1)(\alpha+\beta+k+1)(\alpha+\beta+2k)P_{k+1}^{(\alpha,\beta)}(x) = \\ & = \left( (\alpha+\beta+2k)(\alpha+\beta+2k+2)x + \alpha^2 - \beta^2 \right) (\alpha+\beta+2k+1)P_k^{(\alpha,\beta)}(x) - \\ & - 2(\alpha+k)(\beta+k)(\alpha+\beta+2k+2)P_{k-1}^{(\alpha,\beta)}(x). \end{aligned}$$

Для обобщенных многочленов Лагерра справедливо следующее рекуррентное соотношение [13, 15]:

$$(k+1)L_{k+1}^{(\alpha)}(x) = (\alpha+2k+1-x)L_k^{(\alpha)}(x) - (\alpha+k)L_{k-1}^{(\alpha)}(x).$$

Аналогичные соотношения для ортогональных функций получены с учетом замен переменных, приведенных в Главе 1 [9].

### 9.1 Рекуррентные соотношения для ортогональных функций

$$[9.1] \quad L_k(\tau, \gamma) = \frac{2k-1-\gamma\tau}{k} L_{k-1}(\tau, \gamma) - \frac{k-1}{k} L_{k-2}(\tau, \gamma).$$

$$[9.2] \quad L_k^{(1)}(\tau, \gamma) = \frac{2k-\gamma\tau}{k} L_{k-1}^{(1)}(\tau, \gamma) - L_{k-2}^{(1)}(\tau, \gamma).$$

$$[9.3] \quad L_k^{(2)}(\tau, \gamma) = \frac{2k+1-\gamma\tau}{k} L_{k-1}^{(2)}(\tau, \gamma) - \frac{k+1}{k} L_{k-2}^{(2)}(\tau, \gamma).$$

$$[9.4] \quad L_k^{(\alpha)}(\tau, \gamma) = \frac{2k+\alpha-1-\gamma\tau}{k} L_{k-1}^{(\alpha)}(\tau, \gamma) - \frac{k+\alpha-1}{k} L_{k-2}^{(\alpha)}(\tau, \gamma).$$

$$[9.5] \quad \begin{aligned} P_k^{(-1/2,0)}(\tau, \gamma) &= \\ &= \frac{\left( (4k-5)(4k-1)(1-2\exp(-2\gamma\tau)) + 1 \right)}{4k(4k-5)(2k-1)} \times \\ &\times (4k-3)P_{k-1}^{(-1/2,0)}(\tau, \gamma) - \frac{(k-1)(2k-3)(4k-1)}{k(2k-1)(4k-5)} \times \\ &\times P_{k-2}^{(-1/2,0)}(\tau, \gamma). \end{aligned}$$

$$[9.6] \quad \begin{aligned} Leg_k(\tau, \gamma) &= \frac{2k-1}{k} (1-2\exp(-2\gamma\tau)) \times \\ &\times Leg_{k-1}(\tau, \gamma) - \frac{k-1}{k} Leg_{k-2}(\tau, \gamma). \end{aligned}$$

$$[9.7] \quad \begin{aligned} P_k^{(1/2,0)}(\tau, \gamma) &= \\ &= \frac{\left( (4k-3)(4k+1)(1-2\exp(-2\gamma\tau)) + 1 \right)}{4k(4k-3)(2k+1)} \times \\ &\times (4k-1)P_{k-1}^{(1/2,0)}(\tau, \gamma) - \frac{(k-1)(2k-1)(4k+1)}{k(2k+1)(4k-3)} \times \\ &\times P_{k-2}^{(1/2,0)}(\tau, \gamma). \end{aligned}$$

$$\begin{aligned}
 [9.8] \quad P_k^{(1,0)}(\tau, \gamma) &= \\
 &= \frac{\left( (2k-1)(2k+1)(1-2\exp(-\gamma\tau)) + 1 \right)}{(2k-1)(k+1)} \times \\
 &\quad \times P_{k-1}^{(1,0)}(\tau, \gamma) - \frac{(k-1)(2k+1)}{(2k-1)(k+1)} P_{k-2}^{(1,0)}(\tau, \gamma).
 \end{aligned}$$

$$\begin{aligned}
 [9.9] \quad P_k^{(2,0)}(\tau, \gamma) &= \\
 &= \frac{\left( k(k+1)(1-2\exp(-2\gamma\tau)) + 1 \right)(2k+1)}{k^2(k+2)} \times \\
 &\quad \times P_{k-1}^{(2,0)}(\tau, \gamma) - \frac{(k-1)(k+1)^2}{k^2(k+2)} P_{k-2}^{(2,0)}(\tau, \gamma).
 \end{aligned}$$

$$\begin{aligned}
 [9.10] \quad P_k^{(\alpha,0)}(\tau, \gamma) &= \\
 &= \frac{\left( (\alpha+2k)(\alpha+2k-2)(1-2\exp(-c\gamma\tau)) + \alpha^2 \right)}{2k(\alpha+2k-2)(\alpha+k)} \times \\
 &\quad \times (\alpha+2k-1) P_{k-1}^{(\alpha,0)}(\tau, \gamma) - \frac{(\alpha+k-1)(k-1)(\alpha+2k)}{k(\alpha+2k-2)(\alpha+k)} \times \\
 &\quad \times P_{k-2}^{(\alpha,0)}(\tau, \gamma).
 \end{aligned}$$

$$\begin{aligned}
 [9.11] \quad P_k^{(0,1)}(\tau, \gamma) &= \\
 &= \frac{\left( (2k-1)(2k+1)(1-2\exp(-2\gamma\tau)) - 1 \right)}{(k+1)(2k-1)} \times \\
 &\quad \times P_{k-1}^{(0,1)}(\tau, \gamma) - \frac{(k-1)(2k+1)}{(k+1)(2k-1)} P_{k-2}^{(0,1)}(\tau, \gamma).
 \end{aligned}$$

$$\begin{aligned}
 [9.12] \quad P_k^{(0,2)}(\tau, \gamma) &= \\
 &= \frac{\left( k(k+1)(1-2\exp(-2\gamma\tau)) - 1 \right)(2k+1)}{k^2(k+2)} \times \\
 &\quad \times P_{k-1}^{(0,2)}(\tau, \gamma) - \frac{(k-1)(k+1)^2}{k^2(k+2)} P_{k-2}^{(0,2)}(\tau, \gamma).
 \end{aligned}$$

$$\begin{aligned}
 [9.13] \quad P_k^{(0,\beta)}(\tau, \gamma) &= \\
 &= \frac{\left( (\beta+2k)(\beta+2k-2)(1-2\exp(-c\gamma\tau)) - \beta^2 \right)}{2k(\beta+2k-2)(\beta+k)} \times \\
 &\quad \times (\beta+2k-1) P_{k-1}^{(0,\beta)}(\tau, \gamma) - \frac{(\beta+k-1)(k-1)(\beta+2k)}{k(\beta+2k-2)(\beta+k)} \times \\
 &\quad \times P_{k-2}^{(0,\beta)}(\tau, \gamma).
 \end{aligned}$$

## 9.2 Рекуррентные соотношения для производных ортогональных функций

$$\begin{aligned}
 [9.14] \quad \frac{\partial P_k^{(-1/2,0)}(\tau, \gamma)}{\partial \tau} &= \frac{\partial P_{k-2}^{(-1/2,0)}(\tau, \gamma)}{\partial \tau} - \\
 &- \gamma \left( \frac{(4k+1)}{2} P_k^{(-1/2,0)}(\tau, \gamma) - (4k-3) P_{k-1}^{(-1/2,0)}(\tau, \gamma) + \right. \\
 &\quad \left. + \frac{(4k-7)}{2} P_{k-2}^{(-1/2,0)}(\tau, \gamma) \right).
 \end{aligned}$$

$$\begin{aligned}
 [9.15] \quad \frac{\partial Leg_k(\tau, \gamma)}{\partial \tau} &= \frac{\partial Leg_{k-2}(\tau, \gamma)}{\partial \tau} - \\
 &- \gamma \left( (2k+1) Leg_k(\tau, \gamma) - 2(2k-1) Leg_{k-1}(\tau, \gamma) + \right. \\
 &\quad \left. + (2k-3) Leg_{k-2}(\tau, \gamma) \right).
 \end{aligned}$$

$$\begin{aligned}
 [9.16] \quad \frac{\partial P_k^{(1/2,0)}(\tau, \gamma)}{\partial \tau} &= \frac{\partial P_{k-2}^{(1/2,0)}(\tau, \gamma)}{\partial \tau} - \\
 &- \gamma \left( \frac{(4k+3)}{2} P_k^{(1/2,0)}(\tau, \gamma) - (4k-1) P_{k-1}^{(1/2,0)}(\tau, \gamma) + \right. \\
 &\quad \left. + \frac{(4k-5)}{2} P_{k-2}^{(1/2,0)}(\tau, \gamma) \right).
 \end{aligned}$$

$$\begin{aligned}
 [9.17] \quad \frac{\partial P_k^{(1,0)}(\tau, \gamma)}{\partial \tau} &= \frac{\partial P_{k-2}^{(1,0)}(\tau, \gamma)}{\partial \tau} - \\
 &- \gamma \left( (k+1) P_k^{(1,0)}(\tau, \gamma) - 2k P_{k-1}^{(1,0)}(\tau, \gamma) + \right. \\
 &\quad \left. + (k-1) P_{k-2}^{(1,0)}(\tau, \gamma) \right).
 \end{aligned}$$

$$\begin{aligned}
 [9.18] \quad \frac{\partial P_k^{(2,0)}(\tau, \gamma)}{\partial \tau} &= \frac{\partial P_{k-2}^{(2,0)}(\tau, \gamma)}{\partial \tau} - \\
 &- \gamma \left( (2k+3) P_k^{(2,0)}(\tau, \gamma) - 2(2k+1) P_{k-1}^{(2,0)}(\tau, \gamma) + \right. \\
 &\quad \left. + (2k-1) P_{k-2}^{(2,0)}(\tau, \gamma) \right).
 \end{aligned}$$

$$\begin{aligned}
 [9.19] \quad \frac{\partial P_k^{(\alpha,0)}(\tau, \gamma)}{\partial \tau} &= \frac{\partial P_{k-2}^{(\alpha,0)}(\tau, \gamma)}{\partial \tau} - \\
 &- c\gamma/2 \left( (\alpha+2k+1) P_k^{(\alpha,0)}(\tau, \gamma) - 2(\alpha+2k-1) \times \right. \\
 &\quad \left. \times P_{k-1}^{(\alpha,0)}(\tau, \gamma) + (\alpha+2k-3) P_{k-2}^{(\alpha,0)}(\tau, \gamma) \right).
 \end{aligned}$$

$$\begin{aligned}
 [9.20] \quad \frac{\partial P_k^{(0,1)}(\tau, \gamma)}{\partial \tau} &= \\
 &= \frac{(2k+1)}{(k+1)} \left( \frac{\partial Leg_k(\tau, \gamma)}{\partial \tau} + \frac{\partial Leg_{k-1}(\tau, \gamma)}{\partial \tau} \right) - \\
 &- \frac{((2k-1)(2k+1)+1)}{(k+1)(2k-1)} \frac{\partial P_{k-1}^{(0,1)}(\tau, \gamma)}{\partial \tau} - \\
 &- \frac{(k-1)(2k+1)}{(k+1)(2k-1)} \frac{\partial P_{k-2}^{(0,1)}(\tau, \gamma)}{\partial \tau}.
 \end{aligned}$$

$$\begin{aligned}
 [9.21] \quad & \frac{\partial P_k^{(0,2)}(\tau, \gamma)}{\partial \tau} = \\
 & = \frac{2(k+1)}{k(k+2)} \left( k \frac{\partial P_k^{(0,1)}(\tau, \gamma)}{\partial \tau} + (k+1) \frac{\partial P_{k-1}^{(0,1)}(\tau, \gamma)}{\partial \tau} \right) - \\
 & - \frac{(k(k+1)+1)}{k^2(k+2)} (2k+1) \frac{\partial P_{k-1}^{(0,2)}(\tau, \gamma)}{\partial \tau} - \\
 & - \frac{(k-1)(k+1)^2}{k^2(k+2)} \frac{\partial P_{k-2}^{(0,2)}(\tau, \gamma)}{\partial \tau}.
 \end{aligned}$$

$$\begin{aligned}
 [9.22] \quad & \frac{\partial P_k^{(0,\beta)}(\tau, \gamma)}{\partial \tau} = \frac{(\beta+2k)}{k(\beta+k)} \times \\
 & \times \left( k \frac{\partial P_k^{(0,\beta-1)}(\tau, \gamma)}{\partial \tau} + (k+\beta-1) \frac{\partial P_{k-1}^{(0,\beta-1)}(\tau, \gamma)}{\partial \tau} \right) - \\
 & - \frac{((\beta+2k)(\beta+2k-2)+1)}{2k(\beta+2k-2)(\beta+k)} (\beta+2k-1) \frac{\partial P_{k-1}^{(0,\beta)}(\tau, \gamma)}{\partial \tau} - \\
 & - \frac{(\beta+k-1)(k-1)(\beta+2k)}{k(\beta+2k-2)(\beta+k)} \frac{\partial P_{k-2}^{(0,\beta)}(\tau, \gamma)}{\partial \tau}.
 \end{aligned}$$

**9.3 Рекуррентные соотношения для неопределенных интегралов от ортогональных функций**

$$[9.23] \quad \int L_k(\tau, \gamma) d\tau = -2 \sum_{\nu=0}^{k-1} \int L_\nu(\tau, \gamma) d\tau - \frac{2}{\gamma} L_k(\tau, \gamma).$$

$$\begin{aligned}
 [9.24] \quad & \int \tau L_k(\tau, \gamma) d\tau = -\frac{k+1}{\gamma} \int L_{k+1}(\tau, \gamma) d\tau + \\
 & + \frac{2k+1}{\gamma} \int L_k(\tau, \gamma) d\tau - \frac{k}{\gamma} \int L_{k-1}(\tau, \gamma) d\tau.
 \end{aligned}$$

$$\begin{aligned}
 [9.25] \quad & \int \tau L_k(\tau, \gamma) d\tau = -\frac{4}{\gamma} \sum_{\nu=0}^{k-1} (L_\nu(\tau, \gamma) \tau - \\
 & - \int L_\nu(\tau, \gamma) d\tau) (-1)^{k+\nu} - \frac{2}{\gamma} (L_k(\tau, \gamma) \tau - \int L_k(\tau, \gamma) d\tau).
 \end{aligned}$$

$$\begin{aligned}
 [9.26] \quad & \int L_k^{(1)}(\tau, \gamma) \mu^{\{L_k^{(1)}(\tau, \gamma)\}}(\tau, \gamma) d\tau = \\
 & = \int \tau L_k(\tau, \gamma) d\tau + \int L_{k-1}^{(1)}(\tau, \gamma) \mu^{\{L_k^{(1)}(\tau, \gamma)\}}(\tau, \gamma) d\tau.
 \end{aligned}$$

$$\begin{aligned}
 [9.27] \quad & \int L_k^{(1)}(\tau, \gamma) \mu^{\{L_k^{(1)}(\tau, \gamma)\}}(\tau, \gamma) d\tau = \\
 & = -\frac{1}{2} \int \tau L_{k+1}(\tau, \gamma) d\tau + \frac{1}{\gamma} \int L_{k+1}(\tau, \gamma) d\tau - \frac{1}{\gamma} \tau L_{k+1}(\tau, \gamma).
 \end{aligned}$$

$$\begin{aligned}
 [9.28] \quad & \int \tau L_k^{(1)}(\tau, \gamma) \mu^{\{L_k^{(1)}(\tau, \gamma)\}}(\tau, \gamma) d\tau = \\
 & = -\frac{k+1}{\gamma} \int L_{k+1}^{(1)}(\tau, \gamma) \mu^{\{L_k^{(1)}(\tau, \gamma)\}}(\tau, \gamma) d\tau + \frac{2(k+1)}{\gamma} \times \\
 & \times \int L_k^{(1)}(\tau, \gamma) \mu^{\{L_k^{(1)}(\tau, \gamma)\}}(\tau, \gamma) d\tau - \\
 & - \frac{k+1}{\gamma} \int L_{k-1}^{(1)}(\tau, \gamma) \mu^{\{L_k^{(1)}(\tau, \gamma)\}}(\tau, \gamma) d\tau.
 \end{aligned}$$

$$\begin{aligned}
 [9.29] \quad & \int L_k^{(2)}(\tau, \gamma) \mu^{\{L_k^{(2)}(\tau, \gamma)\}}(\tau, \gamma) d\tau = \\
 & = \int \tau L_k^{(1)}(\tau, \gamma) \mu^{\{L_k^{(1)}(\tau, \gamma)\}}(\tau, \gamma) d\tau + \\
 & + \int \tau L_{k-1}^{(2)}(\tau, \gamma) \mu^{\{L_k^{(1)}(\tau, \gamma)\}}(\tau, \gamma) d\tau.
 \end{aligned}$$

$$\begin{aligned}
 [9.30] \quad & \int L_k^{(2)}(\tau, \gamma) \mu^{\{L_k^{(2)}(\tau, \gamma)\}}(\tau, \gamma) d\tau = \\
 & = -\frac{1}{2} \int \tau L_{k+1}^{(1)}(\tau, \gamma) \mu^{\{L_k^{(1)}(\tau, \gamma)\}}(\tau, \gamma) d\tau + \frac{2}{\gamma} \times \\
 & \times \int L_{k+1}^{(1)}(\tau, \gamma) \mu^{\{L_k^{(1)}(\tau, \gamma)\}}(\tau, \gamma) d\tau - \frac{1}{\gamma} \tau^2 L_{k+1}^{(1)}(\tau, \gamma).
 \end{aligned}$$

$$\begin{aligned}
 [9.31] \quad & \int \tau L_k^{(2)}(\tau, \gamma) \mu^{\{L_k^{(2)}(\tau, \gamma)\}}(\tau, \gamma) d\tau = \\
 & = -\frac{k+1}{\gamma} \int L_{k+1}^{(2)}(\tau, \gamma) \mu^{\{L_k^{(2)}(\tau, \gamma)\}}(\tau, \gamma) d\tau + \frac{2k+3}{\gamma} \times \\
 & \times \int L_k^{(2)}(\tau, \gamma) \mu^{\{L_k^{(2)}(\tau, \gamma)\}}(\tau, \gamma) d\tau - \\
 & - \frac{k+2}{\gamma} \int L_{k-1}^{(2)}(\tau, \gamma) \mu^{\{L_k^{(2)}(\tau, \gamma)\}}(\tau, \gamma) d\tau.
 \end{aligned}$$

$$\begin{aligned}
 [9.32] \quad & \int L_k^{(\alpha)}(\tau, \gamma) \mu^{\{L_k^{(\alpha)}(\tau, \gamma)\}}(\tau, \gamma) d\tau = \\
 & = \int L_k^{(\alpha-1)}(\tau, \gamma) \mu^{\{L_k^{(\alpha)}(\tau, \gamma)\}}(\tau, \gamma) d\tau + \\
 & + \int L_{k-1}^{(\alpha)}(\tau, \gamma) \mu^{\{L_k^{(\alpha)}(\tau, \gamma)\}}(\tau, \gamma) d\tau.
 \end{aligned}$$

$$\begin{aligned}
 [9.33] \quad & \int L_k^{(\alpha)}(\tau, \gamma) \mu^{\{L_k^{(\alpha)}(\tau, \gamma)\}}(\tau, \gamma) d\tau = \\
 & = -\frac{1}{2} \int \tau L_{k+1}^{(\alpha-1)}(\tau, \gamma) \mu^{\{L_k^{(\alpha-1)}(\tau, \gamma)\}}(\tau, \gamma) d\tau + \frac{\alpha}{\gamma} \times \\
 & \times \int L_{k+1}^{(\alpha-1)}(\tau, \gamma) \mu^{\{L_k^{(\alpha-1)}(\tau, \gamma)\}}(\tau, \gamma) d\tau - \frac{1}{\gamma} \tau^\alpha \times \\
 & \times L_{k+1}^{(\alpha-1)}(\tau, \gamma).
 \end{aligned}$$

$$\begin{aligned}
 [9.34] \quad & \int \tau L_k^{(\alpha)}(\tau, \gamma) \mu^{\{L_k^{(\alpha)}(\tau, \gamma)\}}(\tau, \gamma) d\tau = \\
 & = -\frac{k+1}{\gamma} \int L_{k+1}^{(\alpha)}(\tau, \gamma) \mu^{\{L_k^{(\alpha)}(\tau, \gamma)\}}(\tau, \gamma) d\tau + \\
 & + \frac{2k+\alpha+1}{\gamma} \int L_k^{(\alpha)}(\tau, \gamma) \mu^{\{L_k^{(\alpha)}(\tau, \gamma)\}}(\tau, \gamma) d\tau - \\
 & - \frac{k+\alpha}{\gamma} \int L_{k-1}^{(\alpha)}(\tau, \gamma) \mu^{\{L_k^{(\alpha)}(\tau, \gamma)\}}(\tau, \gamma) d\tau.
 \end{aligned}$$

$$\begin{aligned}
[9.35] \quad & \int P_k^{(-1/2,0)}(\tau, \gamma) d\tau = \frac{2(4k-3)}{4k+1} \times \\
& \times \int P_{k-1}^{(-1/2,0)}(\tau, \gamma) d\tau - \frac{(4k-7)}{4k+1} \int P_{k-2}^{(-1/2,0)}(\tau, \gamma) d\tau - \\
& - \frac{2}{\gamma(4k+1)} \left( P_k^{(-1/2,0)}(\tau, \gamma) - P_{k-2}^{(-1/2,0)}(\tau, \gamma) \right).
\end{aligned}$$

$$\begin{aligned}
[9.36] \quad & \int \tau P_k^{(-1/2,0)}(\tau, \gamma) d\tau = \frac{2(4k-3)}{4k+1} \times \\
& \times \int \tau P_{k-1}^{(-1/2,0)}(\tau, \gamma) d\tau - \frac{(4k-7)}{4k+1} \times \\
& \times \int \tau P_{k-2}^{(-1/2,0)}(\tau, \gamma) d\tau - \frac{2}{\gamma(4k+1)} \times \\
& \times \left( \left( P_k^{(-1/2,0)}(\tau, \gamma) - P_{k-2}^{(-1/2,0)}(\tau, \gamma) \right) \tau - \right. \\
& \left. - \int P_k^{(-1/2,0)}(\tau, \gamma) d\tau + \int P_{k-2}^{(-1/2,0)}(\tau, \gamma) d\tau \right).
\end{aligned}$$

$$\begin{aligned}
[9.37] \quad & \int \tau P_k^{(-1/2,0)}(\tau, \gamma) d\tau = -\frac{4}{\gamma(4k+1)} \times \\
& \times \sum_{\nu=0}^{k-1} \left( P_\nu^{(-1/2,0)}(\tau, \gamma) \tau - \int P_\nu^{(-1/2,0)}(\tau, \gamma) d\tau \right) - \\
& - \frac{2}{\gamma(4k+1)} \left( P_k^{(-1/2,0)}(\tau, \gamma) \tau - \int P_k^{(-1/2,0)}(\tau, \gamma) d\tau \right).
\end{aligned}$$

$$\begin{aligned}
[9.38] \quad & \int Leg_k(\tau, \gamma) d\tau = \frac{2(2k-1)}{2k+1} \int Leg_{k-1}(\tau, \gamma) d\tau - \\
& - \frac{(2k-3)}{2k+1} \int Leg_{k-2}(\tau, \gamma) d\tau - \frac{1}{\gamma(2k+1)} \times \\
& \times \left( Leg_k(\tau, \gamma) - Leg_{k-2}(\tau, \gamma) \right).
\end{aligned}$$

$$\begin{aligned}
[9.39] \quad & \int \tau Leg_k(\tau, \gamma) d\tau = \frac{2(2k-1)}{2k+1} \times \\
& \times \int \tau Leg_{k-1}(\tau, \gamma) d\tau - \frac{(2k-3)}{2k+1} \int \tau Leg_{k-2}(\tau, \gamma) d\tau - \\
& - \frac{1}{\gamma(2k+1)} \left( \left( Leg_k(\tau, \gamma) - Leg_{k-2}(\tau, \gamma) \right) \tau - \right. \\
& \left. - \int Leg_k(\tau, \gamma) d\tau + \int Leg_{k-2}(\tau, \gamma) d\tau \right).
\end{aligned}$$

$$\begin{aligned}
[9.40] \quad & \int \tau Leg_k(\tau, \gamma) d\tau = -\frac{2}{\gamma(2k+1)} \times \\
& \times \sum_{\nu=0}^{k-1} \left( Leg_\nu(\tau, \gamma) \tau - \int Leg_\nu(\tau, \gamma) d\tau \right) - \\
& - \frac{1}{\gamma(2k+1)} \left( Leg_k(\tau, \gamma) \tau - \int Leg_k(\tau, \gamma) d\tau \right).
\end{aligned}$$

$$\begin{aligned}
[9.41] \quad & \int P_k^{(1/2,0)}(\tau, \gamma) d\tau = \frac{2(4k-1)}{4k+3} \times \\
& \times \int P_{k-1}^{(1/2,0)}(\tau, \gamma) d\tau - \frac{(4k-5)}{4k+3} \int P_{k-2}^{(1/2,0)}(\tau, \gamma) d\tau - \\
& - \frac{2}{\gamma(4k+3)} \left( P_k^{(1/2,0)}(\tau, \gamma) - P_{k-2}^{(1/2,0)}(\tau, \gamma) \right).
\end{aligned}$$

$$\begin{aligned}
[9.42] \quad & \int \tau P_k^{(1/2,0)}(\tau, \gamma) d\tau = \frac{2(4k-1)}{4k+3} \times \\
& \times \int \tau P_{k-1}^{(1/2,0)}(\tau, \gamma) d\tau - \frac{(4k-5)}{4k+3} \int \tau P_{k-2}^{(1/2,0)}(\tau, \gamma) d\tau - \\
& - \frac{2}{\gamma(4k+3)} \left( \left( P_k^{(1/2,0)}(\tau, \gamma) - P_{k-2}^{(1/2,0)}(\tau, \gamma) \right) \tau - \right. \\
& \left. - \int P_k^{(1/2,0)}(\tau, \gamma) d\tau + \int P_{k-2}^{(1/2,0)}(\tau, \gamma) d\tau \right).
\end{aligned}$$

$$\begin{aligned}
[9.43] \quad & \int \tau P_k^{(1/2,0)}(\tau, \gamma) d\tau = -\frac{4}{\gamma(4k+3)} \times \\
& \times \sum_{\nu=0}^{k-1} \left( P_\nu^{(1/2,0)}(\tau, \gamma) \tau - \int P_\nu^{(1/2,0)}(\tau, \gamma) d\tau \right) - \\
& - \frac{2}{\gamma(4k+3)} \left( P_k^{(1/2,0)}(\tau, \gamma) \tau - \int P_k^{(1/2,0)}(\tau, \gamma) d\tau \right).
\end{aligned}$$

$$\begin{aligned}
[9.44] \quad & \int P_k^{(1,0)}(\tau, \gamma) d\tau = \frac{2k}{k+1} \int P_{k-1}^{(1,0)}(\tau, \gamma) d\tau - \\
& - \frac{(k-1)}{k+1} \int P_{k-2}^{(1,0)}(\tau, \gamma) d\tau - \frac{1}{\gamma(k+1)} \times \\
& \times \left( P_k^{(1,0)}(\tau, \gamma) - P_{k-2}^{(1,0)}(\tau, \gamma) \right).
\end{aligned}$$

$$\begin{aligned}
[9.45] \quad & \int \tau P_k^{(1,0)}(\tau, \gamma) d\tau = \frac{2k}{k+1} \int \tau P_{k-1}^{(1,0)}(\tau, \gamma) d\tau - \\
& - \frac{k-1}{k+1} \int \tau P_{k-2}^{(1,0)}(\tau, \gamma) d\tau - \frac{1}{\gamma(k+1)} \left( \left( P_k^{(1,0)}(\tau, \gamma) - \right. \right. \\
& \left. \left. - P_{k-2}^{(1,0)}(\tau, \gamma) \right) \tau - \int P_k^{(1,0)}(\tau, \gamma) d\tau + \int P_{k-2}^{(1,0)}(\tau, \gamma) d\tau \right).
\end{aligned}$$

$$\begin{aligned}
[9.46] \quad & \int \tau P_k^{(1,0)}(\tau, \gamma) d\tau = -\frac{2}{\gamma(k+1)} \times \\
& \times \sum_{\nu=0}^{k-1} \left( P_\nu^{(1,0)}(\tau, \gamma) \tau - \int P_\nu^{(1,0)}(\tau, \gamma) d\tau \right) - \\
& - \frac{1}{\gamma(k+1)} \left( P_k^{(1,0)}(\tau, \gamma) \tau - \int P_k^{(1,0)}(\tau, \gamma) d\tau \right).
\end{aligned}$$

$$\begin{aligned}
[9.47] \quad & \int P_k^{(2,0)}(\tau, \gamma) d\tau = \frac{2(2k+1)}{2k+3} \int P_{k-1}^{(2,0)}(\tau, \gamma) d\tau - \\
& - \frac{(2k-1)}{2k+3} \int P_{k-2}^{(2,0)}(\tau, \gamma) d\tau - \frac{1}{\gamma(2k+3)} \times \\
& \times \left( P_k^{(2,0)}(\tau, \gamma) - P_{k-2}^{(2,0)}(\tau, \gamma) \right).
\end{aligned}$$

$$\begin{aligned}
[9.48] \quad & \int \tau P_k^{(2,0)}(\tau, \gamma) d\tau = \frac{2(2k+1)}{2k+3} \times \\
& \times \int \tau P_{k-1}^{(2,0)}(\tau, \gamma) d\tau - \frac{2k-1}{2k+3} \int \tau P_{k-2}^{(2,0)}(\tau, \gamma) d\tau - \\
& - \frac{1}{\gamma(2k+3)} \left( \left( P_k^{(2,0)}(\tau, \gamma) - P_{k-2}^{(2,0)}(\tau, \gamma) \right) \tau - \right. \\
& \quad \left. - \int P_k^{(2,0)}(\tau, \gamma) d\tau + \int P_{k-2}^{(2,0)}(\tau, \gamma) d\tau \right).
\end{aligned}$$

$$\begin{aligned}
[9.49] \quad & \int \tau P_k^{(2,0)}(\tau, \gamma) d\tau = -\frac{2}{\gamma(2k+3)} \times \\
& \times \sum_{\nu=0}^{k-1} \left( P_\nu^{(2,0)}(\tau, \gamma) \tau - \int P_\nu^{(2,0)}(\tau, \gamma) d\tau \right) - \\
& - \frac{1}{\gamma(2k+3)} \left( P_k^{(2,0)}(\tau, \gamma) \tau - \int P_k^{(2,0)}(\tau, \gamma) d\tau \right).
\end{aligned}$$

$$\begin{aligned}
[9.50] \quad & \int P_k^{(\alpha,0)}(\tau, \gamma) d\tau = \frac{2(\alpha+2k-1)}{\alpha+2k+1} \times \\
& \times \int P_{k-1}^{(\alpha,0)}(\tau, \gamma) d\tau - \frac{(\alpha+2k-3)}{\alpha+2k+1} \int P_{k-2}^{(\alpha,0)}(\tau, \gamma) d\tau - \\
& - \frac{2}{c\gamma(\alpha+2k+1)} \left( P_k^{(\alpha,0)}(\tau, \gamma) - P_{k-2}^{(\alpha,0)}(\tau, \gamma) \right).
\end{aligned}$$

$$\begin{aligned}
[9.51] \quad & \int \tau P_k^{(\alpha,0)}(\tau, \gamma) d\tau = \frac{2(\alpha+2k-1)}{\alpha+2k+1} \times \\
& \times \int \tau P_{k-1}^{(\alpha,0)}(\tau, \gamma) d\tau - \frac{\alpha+2k-3}{\alpha+2k+1} \int \tau P_{k-2}^{(\alpha,0)}(\tau, \gamma) d\tau - \\
& - \frac{2}{c\gamma(\alpha+2k+1)} \left( \left( P_k^{(\alpha,0)}(\tau, \gamma) - P_{k-2}^{(\alpha,0)}(\tau, \gamma) \right) \tau - \right. \\
& \quad \left. - \int P_k^{(\alpha,0)}(\tau, \gamma) d\tau + \int P_{k-2}^{(\alpha,0)}(\tau, \gamma) d\tau \right).
\end{aligned}$$

$$\begin{aligned}
[9.52] \quad & \int \tau P_k^{(\alpha,0)}(\tau, \gamma) d\tau = -\frac{4}{c\gamma(\alpha+2k+1)} \times \\
& \times \sum_{\nu=0}^{k-1} \left( P_\nu^{(\alpha,0)}(\tau, \gamma) \tau - \int P_\nu^{(\alpha,0)}(\tau, \gamma) d\tau \right) - \\
& - \frac{2}{c\gamma(\alpha+2k+1)} \left( P_k^{(\alpha,0)}(\tau, \gamma) \tau - \int P_k^{(\alpha,0)}(\tau, \gamma) d\tau \right).
\end{aligned}$$

$$\begin{aligned}
[9.53] \quad & \int P_k^{(0,1)}(\tau, \gamma) \mu^{\{P_k^{(0,1)}(\tau, \gamma)\}}(\tau, \gamma) d\tau = \\
& = \frac{1}{2} \left( \int Leg_{k+1}(\tau, \gamma) d\tau + \int Leg_k(\tau, \gamma) d\tau \right).
\end{aligned}$$

$$\begin{aligned}
[9.54] \quad & \int \tau P_k^{(0,1)}(\tau, \gamma) \mu^{\{P_k^{(0,1)}(\tau, \gamma)\}}(\tau, \gamma) d\tau = \\
& = \frac{1}{2} \left( \int \tau Leg_{k+1}(\tau, \gamma) d\tau + \int \tau Leg_k(\tau, \gamma) d\tau \right).
\end{aligned}$$

$$\begin{aligned}
[9.55] \quad & \int P_k^{(0,2)}(\tau, \gamma) \mu^{\{P_k^{(0,2)}(\tau, \gamma)\}}(\tau, \gamma) d\tau = \\
& = \frac{1}{2(2k+3)} \left( (k+1) \int Leg_{k+2}(\tau, \gamma) d\tau + (2k+3) \times \right. \\
& \quad \left. \times \int Leg_{k+1}(\tau, \gamma) d\tau + (k+2) \int Leg_k(\tau, \gamma) d\tau \right).
\end{aligned}$$

$$\begin{aligned}
[9.56] \quad & \int \tau P_k^{(0,2)}(\tau, \gamma) \mu^{\{P_k^{(0,2)}(\tau, \gamma)\}}(\tau, \gamma) d\tau = \\
& = \frac{1}{2(2k+3)} \left( (k+1) \int \tau Leg_{k+2}(\tau, \gamma) d\tau + (2k+3) \times \right. \\
& \quad \left. \times \int \tau Leg_{k+1}(\tau, \gamma) d\tau + (k+2) \int \tau Leg_k(\tau, \gamma) d\tau \right).
\end{aligned}$$

#### 9.4 Рекуррентные соотношения для преобразований Фурье

$$\begin{aligned}
[9.57] \quad & W_k^{\{L_k^{(\alpha+1)}(\tau, \gamma)\}}(j\omega) = \\
& = \frac{1}{\gamma} \left( 1 - W_k^{\{L_k^{(\alpha)}(\tau, \gamma)\}}(j\omega) (j\omega - \gamma/2) \right).
\end{aligned}$$

$$\begin{aligned}
[9.58] \quad & W_k^{\{L_k^{(\alpha+1)}(\tau, \gamma)\}}(j\omega) = \\
& = \frac{1}{\gamma} \left( 1 + W_k^{\{L_k^{(\alpha)}(\tau, \gamma)\}}(j\omega) \frac{\gamma}{2 \cos \varphi} \exp(-j\varphi) \right), \\
& \quad \varphi = \arctan \frac{2\omega}{\gamma}.
\end{aligned}$$

$$\begin{aligned}
[9.59] \quad & V_k^{\{L_k^{(\alpha+1)}(\tau, \gamma)\}}(j\omega) = \\
& = \frac{\gamma}{(j\omega + \gamma/2)} V_k^{\{L_k^{(\alpha)}(\tau, \gamma)\}}(j\omega).
\end{aligned}$$

$$\begin{aligned}
[9.60] \quad & V_k^{\{L_k^{(\alpha+1)}(\tau, \gamma)\}}(j\omega) = \\
& = 2V_k^{\{L_k^{(\alpha)}(\tau, \gamma)\}}(j\omega) \cos \varphi \exp(-j\varphi), \\
& \quad \varphi = \arctan \frac{2\omega}{\gamma}.
\end{aligned}$$



## Глава 10

# Соотношения взаимосвязи базисных функций

### Определение.

Данные определения получены на основе представления функциональной характеристики  $k$  - того порядка  $\vartheta_k(\tau, \gamma)$ , связанной с  $\psi_k(\tau, \gamma)$  в виде [7, 11, 5]

$$\vartheta_k(\tau, \gamma) = \sum_{\nu=0}^{\infty} \beta_{k,\nu} \psi_{\nu}(\tau, \gamma),$$

где

$$\beta_{k,\nu} = \frac{1}{\|\psi_{\nu}(\gamma)\|^2} \int_0^{\infty} \vartheta_k(\tau, \gamma) \psi_{\nu}(\tau, \gamma) \mu^{\{\psi_{\nu}(\tau, \gamma)\}}(\tau, \gamma) d\tau$$

– коэффициенты разложения ряда,  
и понятия расширенного соотношения ортогональности [5].

$$[10.1] \int_0^{\infty} \vartheta_k(\tau, \gamma) \psi_{\nu}(\tau, \gamma) \mu^{\{\psi_{\nu}(\tau, \gamma)\}}(\tau, \gamma) d\tau = h_{k,\nu}(\gamma) \quad (k = 0..K, \nu = 0..K).$$

### 10.1 Соотношения взаимосвязи ортогональных функций

$$[10.2] L_k^{(1)}(\tau, \gamma) = \sum_{\nu=0}^k L_{\nu}(\tau, \gamma).$$

$$[10.3] L_k^{(2)}(\tau, \gamma) = \sum_{\nu=0}^k (k - \nu + 1) L_{\nu}(\tau, \gamma).$$

$$[10.4] L_k(\tau, \gamma) = L_k^{(1)}(\tau, \gamma) - L_{k-1}^{(1)}(\tau, \gamma).$$

$$[10.5] L_k^{(1)}(\tau, \gamma) = L_k^{(2)}(\tau, \gamma) - L_{k-1}^{(2)}(\tau, \gamma).$$

$$[10.6] L_k^{(\alpha+1)}(\tau, \gamma) = \begin{cases} \sum_{\nu=0}^k L_{\nu}(\tau, \gamma), & \text{если } \alpha = 0; \\ \sum_{\nu=0}^k L_{\nu}(\tau, \gamma) \prod_{p=0}^{\alpha-1} \frac{k+p+1-\nu}{p+1}, & \text{если } \alpha > 0, \end{cases}$$

$\alpha \in \mathbb{N}_0.$

$$[10.7] P_k^{(0,1)}(\tau, \gamma) = \frac{1}{k+1} \sum_{\nu=0}^k (2\nu+1)(-1)^{k+\nu} Leg_{\nu}(\tau, \gamma).$$

$$[10.8] P_k^{(0,2)}(\tau, \gamma) = \frac{1}{(k+1)(k+2)} \sum_{\nu=0}^k (2\nu+1)(-1)^{k+\nu} Leg_{\nu}(\tau, \gamma) \times ((k+1)(k+2) - \nu(\nu+1)).$$

$$[10.9] \quad Leg_k(\tau, \gamma) = \frac{(k+1)}{2k+1} P_k^{(0,1)}(\tau, \gamma) + \frac{k}{2k+1} P_{k-1}^{(0,1)}(\tau, \gamma).$$

$$[10.10] \quad P_k^{(0,1)}(\tau, \gamma) = \frac{(k+2)}{2(k+1)} P_k^{(0,2)}(\tau, \gamma) + \frac{k}{2(k+1)} P_{k-1}^{(0,2)}(\tau, \gamma).$$

$$[10.11] \quad P_k^{*(0,\beta+1)}(\tau, \gamma) = \frac{(-1)^k}{k+1} \times \begin{cases} \sum_{\nu=0}^k (2\nu+1)(-1)^\nu Leg_\nu(\tau, \gamma), & \text{если } \beta = 0; \\ \sum_{\nu=0}^k (2\nu+1)(-1)^\nu Leg_\nu(\tau, \gamma) \times \\ \times \prod_{p=0}^{\beta-1} \frac{(k+p+1-\nu)(k+p+2+\nu)}{(p+1)(k+p+2)}, & \text{если } \beta > 0, \end{cases}$$

$\beta \in \mathbb{N}_0$ .

## 10.2 Соотношения взаимосвязи ортогональных функций и производных ортогональных функций

$$[10.12] \quad \frac{\partial L_k(\tau, \gamma)}{\partial \tau} = -\gamma \sum_{\nu=0}^{k-1} L_\nu(\tau, \gamma) - \frac{\gamma}{2} L_k(\tau, \gamma).$$

$$[10.13] \quad \frac{\partial L_k^{(1)}(\tau, \gamma)}{\partial \tau} = -\gamma \sum_{\nu=0}^{k-1} L_\nu^{(1)}(\tau, \gamma) - \frac{\gamma}{2} L_k^{(1)}(\tau, \gamma).$$

$$[10.14] \quad \frac{\partial L_k^{(1)}(\tau, \gamma)}{\partial \tau} = -\frac{\gamma}{2} \sum_{\nu=0}^{k-1} (2(k-\nu)+1) L_\nu(\tau, \gamma) - \frac{\gamma}{2} L_k(\tau, \gamma).$$

$$[10.15] \quad \frac{\partial L_k^{(2)}(\tau, \gamma)}{\partial \tau} = -\gamma \sum_{\nu=0}^{k-1} L_\nu^{(2)}(\tau, \gamma) - \frac{\gamma}{2} L_k^{(2)}(\tau, \gamma).$$

$$[10.16] \quad \frac{\partial L_k^{(2)}(\tau, \gamma)}{\partial \tau} = -\frac{\gamma}{2} \sum_{\nu=0}^{k-1} (k-\nu+1)^2 L_\nu(\tau, \gamma) - \frac{\gamma}{2} L_k(\tau, \gamma).$$

$$[10.17] \quad \frac{\partial L_k^{(\alpha)}(\tau, \gamma)}{\partial \tau} = -\gamma \sum_{\nu=0}^{k-1} L_\nu^{(\alpha)}(\tau, \gamma) - \frac{\gamma}{2} L_k^{(\alpha)}(\tau, \gamma).$$

$$[10.18] \quad \frac{\partial P_k^{(-1/2,0)}(\tau, \gamma)}{\partial \tau} = -\gamma \sum_{\nu=0}^{k-1} (4\nu+1)(-1)^{k+\nu} \times P_\nu^{(-1/2,0)}(\tau, \gamma) - \frac{\gamma(4k+1)}{2} P_k^{(-1/2,0)}(\tau, \gamma).$$

$$[10.19] \quad \frac{\partial Leg_k(\tau, \gamma)}{\partial \tau} = -2\gamma \sum_{\nu=0}^{k-1} (2\nu+1)(-1)^{k+\nu} \times Leg_\nu(\tau, \gamma) - \gamma(2k+1) Leg_k(\tau, \gamma).$$

$$[10.20] \quad \frac{\partial P_k^{(1/2,0)}(\tau, \gamma)}{\partial \tau} = -\gamma \sum_{\nu=0}^{k-1} (4\nu+3)(-1)^{k+\nu} \times P_\nu^{(1/2,0)}(\tau, \gamma) - \frac{\gamma(4k+3)}{2} P_k^{(1/2,0)}(\tau, \gamma).$$

$$[10.21] \quad \frac{\partial P_k^{(1,0)}(\tau, \gamma)}{\partial \tau} = -2\gamma \sum_{\nu=0}^{k-1} (\nu+1)(-1)^{k+\nu} \times P_\nu^{(1,0)}(\tau, \gamma) - \gamma(k+1) P_k^{(1,0)}(\tau, \gamma).$$

$$[10.22] \quad \frac{\partial P_k^{(2,0)}(\tau, \gamma)}{\partial \tau} = -2\gamma \sum_{\nu=0}^{k-1} (2\nu+3)(-1)^{k+\nu} \times P_\nu^{(2,0)}(\tau, \gamma) - \gamma(2k+3) P_k^{(2,0)}(\tau, \gamma).$$

$$[10.23] \quad \frac{\partial P_k^{(\alpha,0)}(\tau, \gamma)}{\partial \tau} = -c\gamma \sum_{\nu=0}^{k-1} (\alpha+2\nu+1)(-1)^{k+\nu} \times P_\nu^{(\alpha,0)}(\tau, \gamma) - c\gamma/2(\alpha+2k+1) P_k^{(\alpha,0)}(\tau, \gamma).$$

$$[10.24] \quad \frac{\partial P_k^{(0,1)}(\tau, \gamma)}{\partial \tau} = -\frac{4\gamma}{(k+1)} \sum_{\nu=0}^{k-1} (\nu+1)^2 (-1)^{k+\nu} \times P_\nu^{(0,1)}(\tau, \gamma) - \gamma(2k+1) P_k^{(0,1)}(\tau, \gamma).$$

$$[10.25] \quad \frac{\partial P_k^{(0,1)}(\tau, \gamma)}{\partial \tau} = -\frac{\gamma}{(k+1)} \sum_{\nu=0}^{k-1} (2k(k+1) - 2\nu(\nu+1) + 2k+1) (-1)^{k+\nu} (2\nu+1) Leg_\nu(\tau, \gamma) - \frac{\gamma(2k+1)^2}{(k+1)} Leg_k(\tau, \gamma).$$

$$[10.26] \quad \frac{\partial P_k^{(0,2)}(\tau, \gamma)}{\partial \tau} = -\frac{2\gamma}{(k+1)(k+2)} \sum_{\nu=0}^{k-1} (\nu+1) \times (\nu+2)(-1)^{k+\nu} (2\nu+3) P_\nu^{(0,2)}(\tau, \gamma) - \gamma(2k+1) P_k^{(0,2)}(\tau, \gamma).$$

$$[10.27] \quad \frac{\partial P_k^{(0,2)}(\tau, \gamma)}{\partial \tau} = -\frac{\gamma}{(k+1)(k+2)} \times \sum_{\nu=0}^{k-1} \left( (k+1)(k+2)(k(k+3)+1) - (2k(k+3)+3) \times \nu(\nu+1) + \nu^2(\nu+1)^2 \right) (-1)^{k+\nu} (2\nu+1) Leg_\nu(\tau, \gamma) - \frac{2\gamma(2k+1)^2}{(k+2)} Leg_k(\tau, \gamma).$$



**10.3 Соотношения взаимосвязи ортогональных функций и неопределенных интегралов от ортогональных функций**

$$[10.28] \quad \int L_k(\tau, \gamma) d\tau = -\frac{4}{\gamma} \sum_{\nu=0}^{k-1} (-1)^{k+\nu} L_\nu(\tau, \gamma) - \frac{2}{\gamma} L_k(\tau, \gamma).$$

$$[10.29] \quad \int P_k^{(-1/2,0)}(\tau, \gamma) d\tau = -\frac{4}{\gamma(4k+1)} \times \sum_{\nu=0}^{k-1} P_\nu^{(-1/2,0)}(\tau, \gamma) - \frac{2}{\gamma(4k+1)} P_k^{(-1/2,0)}(\tau, \gamma).$$

$$[10.30] \quad \int Leg_k(\tau, \gamma) d\tau = -\frac{2}{\gamma(2k+1)} \sum_{\nu=0}^{k-1} Leg_\nu(\tau, \gamma) - \frac{1}{\gamma(2k+1)} Leg_k(\tau, \gamma).$$

$$[10.31] \quad \int P_k^{(1/2,0)}(\tau, \gamma) d\tau = -\frac{4}{\gamma(4k+3)} \times \sum_{\nu=0}^{k-1} P_\nu^{(1/2,0)}(\tau, \gamma) - \frac{2}{\gamma(4k+3)} P_k^{(1/2,0)}(\tau, \gamma).$$

$$[10.32] \quad \int P_k^{(1,0)}(\tau, \gamma) d\tau = -\frac{2}{\gamma(k+1)} \sum_{\nu=0}^{k-1} P_\nu^{(1,0)}(\tau, \gamma) - \frac{1}{\gamma(k+1)} P_k^{(1,0)}(\tau, \gamma).$$

$$[10.33] \quad \int P_k^{(2,0)}(\tau, \gamma) d\tau = -\frac{2}{\gamma(2k+3)} \sum_{\nu=0}^{k-1} P_\nu^{(2,0)}(\tau, \gamma) - \frac{1}{\gamma(2k+3)} P_k^{(2,0)}(\tau, \gamma).$$

$$[10.34] \quad \int P_k^{(\alpha,0)}(\tau, \gamma) d\tau = -\frac{4}{c\gamma(\alpha+2k+1)} \times \sum_{\nu=0}^{k-1} P_\nu^{(\alpha,0)}(\tau, \gamma) - \frac{2}{c\gamma(\alpha+2k+1)} P_k^{(\alpha,0)}(\tau, \gamma).$$

**10.4 Соотношения взаимосвязи преобразований Фурье**

$$[10.35] \quad W_k^{\{L_k^{(1)}(\tau, \gamma)\}}(j\omega) = \sum_{\nu=0}^k W_\nu^{\{L_\nu(\tau, \gamma)\}}(j\omega).$$

$$[10.36] \quad W_k^{\{L_k^{(2)}(\tau, \gamma)\}}(j\omega) = \sum_{\nu=0}^k (k-\nu+1) W_\nu^{\{L_\nu(\tau, \gamma)\}}(j\omega).$$

$$[10.37] \quad W_k^{\{L_k^{(\alpha+1)}(\tau, \gamma)\}}(j\omega) = \begin{cases} \sum_{\nu=0}^k W_\nu^{\{L_\nu(\tau, \gamma)\}}(j\omega), & \text{если } \alpha = 0; \\ \sum_{\nu=0}^k W_\nu^{\{L_\nu(\tau, \gamma)\}}(j\omega) \prod_{p=0}^{\alpha-1} \frac{k+p+1-\nu}{p+1}, & \text{если } \alpha > 0, \end{cases} \quad \alpha \in \mathbb{N}_0.$$

$$[10.38] \quad W_k^{\{P_k^{(0,1)}(\tau, \gamma)\}}(j\omega) = \frac{1}{k+1} \sum_{\nu=0}^k (2\nu+1) \times (-1)^{k+\nu} W_\nu^{\{Leg_\nu(\tau, \gamma)\}}(j\omega).$$

$$[10.39] \quad W_k^{\{P_k^{(0,2)}(\tau, \gamma)\}}(j\omega) = \frac{1}{(k+1)(k+2)} \times \sum_{\nu=0}^k (2\nu+1)(-1)^{k+\nu} ((k+1)(k+2) - \nu(\nu+1)) \times W_\nu^{\{Leg_\nu(\tau, \gamma)\}}(j\omega).$$

$$[10.40] \quad W_k^{\{P_k^{(0,\beta)}(\tau, \gamma)\}}(j\omega) = \frac{(-1)^k}{k+1} \times \begin{cases} \sum_{\nu=0}^k (2\nu+1)(-1)^\nu W_\nu^{\{Leg_\nu(\tau, \gamma)\}}(j\omega), & \text{если } \beta = 0; \\ \sum_{\nu=0}^k (2\nu+1)(-1)^\nu W_\nu^{\{Leg_\nu(\tau, \gamma)\}}(j\omega) \times \prod_{p=0}^{\beta-1} \frac{(k+p+1-\nu)(k+p+2+\nu)}{(p+1)(k+p+2)}, & \text{если } \beta > 0, \end{cases} \quad \beta \in \mathbb{N}_0.$$



## Глава 11

# Обобщенные характеристики ортогональных функций

### Определение.

По аналогии с известными определениями длительности и моментных характеристик введены следующие понятия:

- длительности ортогональных функций во временной области [6]

$$\tau_k^{(2)\{\psi_k(\tau, \gamma)\}} = \frac{\int_0^{\infty} \psi_k(\tau, \gamma) d\tau}{|\psi_k(0, \gamma)|};$$

$$\tau_k^{(4)\{\psi_k(\tau, \gamma)\}} = \frac{\int_0^{\infty} (\psi_k(\tau, \gamma))^2 d\tau}{(\psi_k(0, \gamma))^2};$$

- длительности ортогональных функций в частотной области

$$\Delta\omega_k^{(2)\{\text{Re}W_k^{\{\psi_k(\tau, \gamma)\}}(j\omega)\}} = \frac{\int_0^{\infty} \text{Re}W_k^{\{\psi_k(\tau, \gamma)\}}(j\omega) d\omega}{|\text{Re}W_k^{\{\psi_k(\tau, \gamma)\}}(0)|};$$

$$\Delta\omega_k^{(4)\{\text{Re}W_k^{\{\psi_k(\tau, \gamma)\}}(j\omega)\}} = \frac{\int_0^{\infty} (\text{Re}W_k^{\{\psi_k(\tau, \gamma)\}}(j\omega))^2 d\omega}{(\text{Re}W_k^{\{\psi_k(\tau, \gamma)\}}(0))^2};$$

- моментные характеристики во временной области [6, 14]

$$\mu_k^{(n)[1]\{\psi_k(\tau, \gamma)\}} = \int_0^{\infty} \tau^n \psi_k(\tau, \gamma) d\tau;$$

$$\mu_k^{(n)[2]\{\psi_k(\tau, \gamma)\}} = j^n \left. \frac{d^n W_k^{\{\psi_k(\tau, \gamma)\}}(j\omega)}{d\omega^n} \right|_{j\omega=0};$$

– моментные характеристики в частотной области

$$\mu_k^{(n)[1]\{W_k^{\{\psi_k(\tau, \gamma)\}}(j\omega)\}} = \int_0^\infty \omega^n W_k^{\{\psi_k(\tau, \gamma)\}}(j\omega) d\omega;$$

$$\mu_k^{(n)[2]\{W_k^{\{\psi_k(\tau, \gamma)\}}(j\omega)\}} = \frac{\pi}{2} (-1)^n \left. \frac{\partial^n \psi_k(\tau, \gamma)}{\partial \tau^n} \right|_{\tau=0}.$$

### 11.1 Длительности ортогональных функций во временной области

$$[11.1] \quad \tau_k^{(2)\{L_k(\tau, \gamma)\}} = \frac{2(-1)^k}{\gamma},$$

$$k = 0, 2, 4, \dots, 2n, \quad n \in \mathbb{N}_0.$$

$$[11.2] \quad \tau_k^{(4)\{L_k(\tau, \gamma)\}} = \frac{1}{\gamma}.$$

$$[11.3] \quad \tau_k^{(2)\{L_k^{(1)}(\tau, \gamma)\}} = \frac{2((k+1) \bmod 2)}{\gamma(k+1)},$$

$$k = 0, 2, 4, \dots, 2n, \quad n \in \mathbb{N}_0.$$

$$[11.4] \quad \tau_k^{(4)\{L_k^{(1)}(\tau, \gamma)\}} = \frac{1}{\gamma(k+1)}.$$

$$[11.5] \quad \tau_k^{(2)\{L_k^{(2)}(\tau, \gamma)\}} = \frac{4((k+2) \operatorname{div} 2)}{\gamma(k+1)(k+2)}.$$

$$[11.6] \quad \tau_k^{(4)\{L_k^{(2)}(\tau, \gamma)\}} = \frac{2(2k+3)}{3\gamma(k+1)(k+2)}.$$

$$[11.7] \quad \tau_k^{(2)\{P_k^{(-1/2, 0)}(\tau, \gamma)\}} = \frac{2}{\gamma(4k+1)}.$$

$$[11.8] \quad \tau_k^{(4)\{P_k^{(-1/2, 0)}(\tau, \gamma)\}} = \frac{1}{\gamma(4k+1)}.$$

$$[11.9] \quad \tau_k^{(2)\{Leg_k(\tau, \gamma)\}} = \frac{1}{\gamma(2k+1)}.$$

$$[11.10] \quad \tau_k^{(4)\{Leg_k(\tau, \gamma)\}} = \frac{1}{2\gamma(2k+1)}.$$

$$[11.11] \quad \tau_k^{(2)\{P_k^{(1/2, 0)}(\tau, \gamma)\}} = \frac{2}{\gamma(4k+3)}.$$

$$[11.12] \quad \tau_k^{(4)\{P_k^{(1/2, 0)}(\tau, \gamma)\}} = \frac{1}{\gamma(4k+3)}.$$

$$[11.13] \quad \tau_k^{(2)\{P_k^{(1, 0)}(\tau, \gamma)\}} = \frac{1}{\gamma(k+1)}.$$

$$[11.14] \quad \tau_k^{(4)\{P_k^{(1, 0)}(\tau, \gamma)\}} = \frac{1}{2\gamma(k+1)}.$$

$$[11.15] \quad \tau_k^{(2)\{P_k^{(2, 0)}(\tau, \gamma)\}} = \frac{1}{\gamma(2k+3)}.$$

$$[11.16] \quad \tau_k^{(4)\{P_k^{(2, 0)}(\tau, \gamma)\}} = \frac{1}{2\gamma(2k+3)}.$$

$$[11.17] \quad \tau_k^{(2)\{P_k^{(0, 1)}(\tau, \gamma)\}} = \frac{((k+1) \bmod 2)}{\gamma(k+1)^2},$$

$$k = 0, 2, 4, \dots, 2n, \quad n \in \mathbb{N}_0.$$

$$[11.18] \quad \tau_k^{(4)\{P_k^{(0, 1)}(\tau, \gamma)\}} = \frac{1}{2\gamma(k+1)^2}.$$

$$[11.19] \quad \tau_k^{(2)\{P_k^{(0, 2)}(\tau, \gamma)\}} = \frac{4(-1)^k((k+2) \operatorname{div} 2)^2}{\gamma(k+1)^2(k+2)^2},$$

$$k = 0, 2, 4, \dots, 2n, \quad n \in \mathbb{N}_0.$$

$$[11.20] \quad \tau_k^{(4)\{P_k^{(0, 2)}(\tau, \gamma)\}} = \frac{2((k+1)(k+2)+1)}{3\gamma(k+1)^2(k+2)^2}.$$

### 11.2 Моментные характеристики ортогональных функций во временной области

$$[11.21] \quad \mu_k^{(0)\{L_k(\tau, \gamma)\}} = \frac{2(-1)^k}{\gamma}.$$

$$[11.22] \quad \mu_k^{(1)\{L_k(\tau, \gamma)\}} = \frac{4(-1)^k(2k+1)}{\gamma^2}.$$

$$[11.23] \quad \mu_k^{(2)\{L_k(\tau, \gamma)\}} = \frac{8(-1)^k((2k+1)^2+1)}{\gamma^3}.$$

$$[11.24] \quad \mu_k^{(3)\{L_k(\tau, \gamma)\}} = \frac{16(-1)^k((2k+1)^3+5(2k+1))}{\gamma^4}.$$

$$[11.25] \quad \mu_k^{(n)\{L_k(\tau, \gamma)\}} = n! \left(\frac{2}{\gamma}\right)^{n+1} \sum_{s=0}^k \binom{k}{s} \binom{s+n}{s} (-2)^s.$$

$$[11.26] \quad \mu_k^{(0)\{L_k^{(1)}(\tau, \gamma)\}} = \frac{2((k+1) \bmod 2)}{\gamma}.$$

$$[11.27] \quad \mu_k^{(1)\{L_k^{(1)}(\tau, \gamma)\}} = \frac{4(-1)^k(k+1)}{\gamma^2}.$$

$$[11.28] \quad \mu_k^{(2)\{L_k^{(1)}(\tau, \gamma)\}} = \frac{16(-1)^k(k+1)^2}{\gamma^3}.$$

$$[11.29] \quad \mu_k^{(3)\{L_k^{(1)}(\tau, \gamma)\}} = \\ = \frac{16}{\gamma^4} \sum_{s=0}^k \binom{k+1}{k-s} (-2)^s (s+1)(s+2)(s+3).$$

$$[11.30] \quad \mu_k^{(n)\{L_k^{(1)}(\tau, \gamma)\}} = \\ = n! \left(\frac{2}{\gamma}\right)^{n+1} \sum_{s=0}^k \binom{k+1}{k-s} \binom{s+n}{s} (-2)^s.$$

$$[11.31] \quad \mu_k^{(0)\{L_k^{(2)}(\tau, \gamma)\}} = \frac{2((k+2) \operatorname{div} 2)}{\gamma}.$$

$$[11.32] \quad \mu_k^{(1)\{L_k^{(2)}(\tau, \gamma)\}} = \frac{4(-1)^k ((k+2) \operatorname{div} 2)}{\gamma^2}.$$

$$[11.33] \quad \mu_k^{(2)\{L_k^{(2)}(\tau, \gamma)\}} = \frac{8(-1)^k (k+1)(k+2)}{\gamma^3}.$$

$$[11.34] \quad \mu_k^{(3)\{L_k^{(2)}(\tau, \gamma)\}} = \\ = \frac{16}{\gamma^4} \sum_{s=0}^k \binom{k+2}{k-s} (s+1)(s+2)(s+3)(-2)^s.$$

$$[11.35] \quad \mu_k^{(n)\{L_k^{(2)}(\tau, \gamma)\}} = \\ = n! \left(\frac{2}{\gamma}\right)^{n+1} \sum_{s=0}^k \binom{k+2}{k-s} \binom{s+n}{s} (-2)^s.$$

$$[11.36] \quad \mu_k^{(0)\{L_k^{(\alpha)}(\tau, \gamma)\}} = \frac{2}{\gamma} \sum_{s=0}^k \binom{k+\alpha}{k-s} (-2)^s.$$

$$[11.37] \quad \mu_k^{(1)\{L_k^{(\alpha)}(\tau, \gamma)\}} = \frac{4}{\gamma^2} \sum_{s=0}^k \binom{k+\alpha}{k-s} (-2)^s (s+1).$$

$$[11.38] \quad \mu_k^{(2)\{L_k^{(\alpha)}(\tau, \gamma)\}} = \\ = \frac{8}{\gamma^3} \sum_{s=0}^k \binom{k+\alpha}{k-s} (-2)^s (s+1)(s+2).$$

$$[11.39] \quad \mu_k^{(3)\{L_k^{(\alpha)}(\tau, \gamma)\}} = \\ = \frac{16}{\gamma^4} \sum_{s=0}^k \binom{k+\alpha}{k-s} (-2)^s (s+1)(s+2)(s+3).$$

$$[11.40] \quad \mu_k^{(n)\{L_k^{(\alpha)}(\tau, \gamma)\}} = \\ = n! \left(\frac{2}{\gamma}\right)^{n+1} \sum_{s=0}^k \binom{k+\alpha}{k-s} \binom{s+n}{s} (-2)^s.$$

$$[11.41] \quad \mu_k^{(0)\{P_k^{(-1/2,0)}(\tau, \gamma)\}} = \frac{2}{\gamma(4k+1)}.$$

$$[11.42] \quad \mu_k^{(1)\{P_k^{(-1/2,0)}(\tau, \gamma)\}} = \\ = \frac{4}{\gamma^2} \sum_{s=0}^k \binom{k}{s} \binom{k+s-1/2}{s-1/2} (-1)^s \frac{1}{(4s+1)^2}.$$

$$[11.43] \quad \mu_k^{(2)\{P_k^{(-1/2,0)}(\tau, \gamma)\}} = \\ = \frac{16}{\gamma^3} \sum_{s=0}^k \binom{k}{s} \binom{k+s-1/2}{s-1/2} (-1)^s \frac{1}{(4s+1)^3}.$$

$$[11.44] \quad \mu_k^{(3)\{P_k^{(-1/2,0)}(\tau, \gamma)\}} = \\ = \frac{96}{\gamma^4} \sum_{s=0}^k \binom{k}{s} \binom{k+s-1/2}{s-1/2} (-1)^s \frac{1}{(4s+1)^4}.$$

$$[11.45] \quad \mu_k^{(n)\{P_k^{(-1/2,0)}(\tau, \gamma)\}} = \\ = n! \left(\frac{2}{\gamma}\right)^{n+1} \sum_{s=0}^k \binom{k}{s} \binom{k+s-1/2}{s-1/2} (-1)^s \frac{1}{(4s+1)^{n+1}}.$$

$$[11.46] \quad \mu_k^{(0)\{Leg_k(\tau, \gamma)\}} = \frac{1}{\gamma(2k+1)}.$$

$$[11.47] \quad \mu_k^{(1)\{Leg(\tau, \gamma)\}} = \\ = \frac{1}{\gamma^2} \sum_{s=0}^k \binom{k}{s} \binom{k+s}{s} (-1)^s \frac{1}{(2s+1)^2}.$$

$$[11.48] \quad \mu_k^{(2)\{Leg(\tau, \gamma)\}} = \\ = \frac{2}{\gamma^3} \sum_{s=0}^k \binom{k}{s} \binom{k+s}{s} (-1)^s \frac{1}{(2s+1)^3}.$$

$$[11.49] \quad \mu_k^{(3)\{Leg(\tau, \gamma)\}} = \\ = \frac{6}{\gamma^4} \sum_{s=0}^k \binom{k}{s} \binom{k+s}{s} (-1)^s \frac{1}{(2s+1)^4}.$$

$$[11.50] \quad \mu_k^{(n)\{Leg(\tau, \gamma)\}} = \\ = \frac{n!}{\gamma^{n+1}} \sum_{s=0}^k \binom{k}{s} \binom{k+s}{s} (-1)^s \frac{1}{(2s+1)^{n+1}}.$$

$$[11.51] \quad \mu_k^{(0)\{P_k^{(1/2,0)}(\tau, \gamma)\}} = \frac{2}{\gamma(4k+3)}.$$

$$[11.52] \quad \mu_k^{(1)\{P_k^{(1/2,0)}(\tau, \gamma)\}} = \\ = \frac{4}{\gamma^2} \sum_{s=0}^k \binom{k}{s} \binom{k+s+1/2}{s+1/2} (-1)^s \frac{1}{(4s+3)^2}.$$

$$[11.53] \quad \mu_k^{(2)\{P_k^{(1/2,0)}(\tau, \gamma)\}} = \\ = \frac{16}{\gamma^3} \sum_{s=0}^k \binom{k}{s} \binom{k+s+1/2}{s+1/2} (-1)^s \frac{1}{(4s+3)^3}.$$

$$[11.54] \quad \mu_k^{(3)\{P_k^{(1/2,0)}(\tau,\gamma)\}} = \frac{96}{\gamma^4} \sum_{s=0}^k \binom{k}{s} \binom{k+s+1/2}{s+1/2} (-1)^s \frac{1}{(4s+3)^4}.$$

$$[11.55] \quad \mu_k^{(n)\{P_k^{(1/2,0)}(\tau,\gamma)\}} = n! \left(\frac{2}{\gamma}\right)^{n+1} \sum_{s=0}^k \binom{k}{s} \binom{k+s+1/2}{s+1/2} (-1)^s \frac{1}{(4s+3)^{n+1}}.$$

$$[11.56] \quad \mu_k^{(0)\{P_k^{(1,0)}(\tau,\gamma)\}} = \frac{1}{\gamma(k+1)}.$$

$$[11.57] \quad \mu_k^{(1)\{P_k^{(1,0)}(\tau,\gamma)\}} = \frac{1}{\gamma^2} \sum_{s=0}^k \binom{k}{s} \binom{k+s+1}{s+1} (-1)^s \frac{1}{(s+1)^2}.$$

$$[11.58] \quad \mu_k^{(2)\{P_k^{(1,0)}(\tau,\gamma)\}} = \frac{2}{\gamma^3} \sum_{s=0}^k \binom{k}{s} \binom{k+s+1}{s+1} (-1)^s \frac{1}{(s+1)^3}.$$

$$[11.59] \quad \mu_k^{(3)\{P_k^{(1,0)}(\tau,\gamma)\}} = \frac{6}{\gamma^4} \sum_{s=0}^k \binom{k}{s} \binom{k+s+1}{s+1} (-1)^s \frac{1}{(s+1)^4}.$$

$$[11.60] \quad \mu_k^{(n)\{P_k^{(1,0)}(\tau,\gamma)\}} = \frac{n!}{\gamma^{n+1}} \sum_{s=0}^k \binom{k}{s} \binom{k+s+1}{s+1} (-1)^s \frac{1}{(s+1)^{n+1}}.$$

$$[11.61] \quad \mu_k^{(0)\{P_k^{(2,0)}(\tau,\gamma)\}} = \frac{1}{\gamma(2k+3)}.$$

$$[11.62] \quad \mu_k^{(1)\{P_k^{(2,0)}(\tau,\gamma)\}} = \frac{1}{\gamma^2} \sum_{s=0}^k \binom{k}{s} \binom{k+s+2}{s+2} (-1)^s \frac{1}{(2s+3)^2}.$$

$$[11.63] \quad \mu_k^{(2)\{P_k^{(2,0)}(\tau,\gamma)\}} = \frac{2}{\gamma^3} \sum_{s=0}^k \binom{k}{s} \binom{k+s+2}{s+2} (-1)^s \frac{1}{(2s+3)^3}.$$

$$[11.64] \quad \mu_k^{(3)\{P_k^{(2,0)}(\tau,\gamma)\}} = \frac{6}{\gamma^4} \sum_{s=0}^k \binom{k}{s} \binom{k+s+2}{s+2} (-1)^s \frac{1}{(2s+3)^4}.$$

$$[11.65] \quad \mu_k^{(n)\{P_k^{(2,0)}(\tau,\gamma)\}} = \frac{n!}{\gamma^{n+1}} \sum_{s=0}^k \binom{k}{s} \binom{k+s+2}{s+2} (-1)^s \frac{1}{(2s+3)^{n+1}}.$$

$$[11.66] \quad \mu_k^{(0)\{P_k^{(\alpha,0)}(\tau,\gamma)\}} = \frac{2}{c\gamma(2k+\alpha+1)}.$$

$$[11.67] \quad \mu_k^{(1)\{P_k^{(\alpha,0)}(\tau,\gamma)\}} = \frac{4}{c^2\gamma^2} \sum_{s=0}^k \binom{k}{s} \binom{k+s+\alpha}{s+\alpha} (-1)^s \frac{1}{(2s+\alpha+1)^2}.$$

$$[11.68] \quad \mu_k^{(2)\{P_k^{(\alpha,0)}(\tau,\gamma)\}} = \frac{16}{c^3\gamma^3} \sum_{s=0}^k \binom{k}{s} \binom{k+s+\alpha}{s+\alpha} (-1)^s \frac{1}{(2s+\alpha+1)^3}.$$

$$[11.69] \quad \mu_k^{(3)\{P_k^{(\alpha,0)}(\tau,\gamma)\}} = \frac{96}{c^4\gamma^4} \sum_{s=0}^k \binom{k}{s} \binom{k+s+\alpha}{s+\alpha} (-1)^s \frac{1}{(2s+\alpha+1)^4}.$$

$$[11.70] \quad \mu_k^{(n)\{P_k^{(\alpha,0)}(\tau,\gamma)\}} = \frac{2^{n+1}n!}{(c\gamma)^{n+1}} \sum_{s=0}^k \binom{k}{s} \binom{k+s+\alpha}{s+\alpha} (-1)^s \frac{1}{(2s+\alpha+1)^{n+1}}.$$

$$[11.71] \quad \mu_k^{(0)\{P_k^{(0,1)}(\tau,\gamma)\}} = \frac{1}{\gamma} \sum_{s=0}^k \binom{k}{s} \binom{k+s+1}{s} (-1)^s \frac{1}{(2s+1)}.$$

$$[11.72] \quad \mu_k^{(1)\{P_k^{(0,1)}(\tau,\gamma)\}} = \frac{1}{\gamma^2} \sum_{s=0}^k \binom{k}{s} \binom{k+s+1}{s} (-1)^s \frac{1}{(2s+1)^2}.$$

$$[11.73] \quad \mu_k^{(2)\{P_k^{(0,1)}(\tau,\gamma)\}} = \frac{2}{\gamma^3} \sum_{s=0}^k \binom{k}{s} \binom{k+s+1}{s} (-1)^s \frac{1}{(2s+1)^3}.$$

$$[11.74] \quad \mu_k^{(3)\{P_k^{(0,1)}(\tau,\gamma)\}} = \frac{6}{\gamma^4} \sum_{s=0}^k \binom{k}{s} \binom{k+s+1}{s} (-1)^s \frac{1}{(2s+1)^4}.$$

$$[11.75] \quad \mu_k^{(n)\{P_k^{(0,1)}(\tau,\gamma)\}} = \frac{n!}{\gamma^{n+1}} \sum_{s=0}^k \binom{k}{s} \binom{k+s+1}{s} (-1)^s \frac{1}{(2s+1)^{n+1}}.$$

$$[11.76] \quad \mu_k^{(0)\{P_k^{(0,2)}(\tau,\gamma)\}} = \frac{1}{\gamma} \sum_{s=0}^k \binom{k}{s} \binom{k+s+2}{s} (-1)^s \frac{1}{(2s+1)}.$$

$$[11.77] \quad \mu_k^{(1)\{P_k^{(0,2)}(\tau,\gamma)\}} = \frac{1}{\gamma^2} \sum_{s=0}^k \binom{k}{s} \binom{k+s+2}{s} (-1)^s \frac{1}{(2s+1)^2}.$$

$$[11.78] \quad \mu_k^{(2)\{P_k^{(0,2)}(\tau,\gamma)\}} = \frac{2}{\gamma^3} \sum_{s=0}^k \binom{k}{s} \binom{k+s+2}{s} (-1)^s \frac{1}{(2s+1)^3}.$$

$$[11.79] \quad \mu_k^{(3)\{P_k^{(0,2)}(\tau,\gamma)\}} = \frac{6}{\gamma^4} \sum_{s=0}^k \binom{k}{s} \binom{k+s+2}{s} (-1)^s \frac{1}{(2s+1)^4}.$$

$$[11.80] \quad \mu_k^{(n)\{P_k^{(0,2)}(\tau,\gamma)\}} = \frac{n!}{\gamma^{n+1}} \sum_{s=0}^k \binom{k}{s} \binom{k+s+2}{s} (-1)^s \frac{1}{(2s+1)^{n+1}}.$$

$$[11.81] \quad \mu_k^{(0)\{P_k^{(0,\beta)}(\tau,\gamma)\}} = \frac{1}{\gamma} \sum_{s=0}^k \binom{k}{s} \binom{k+s+\beta}{s} (-1)^s \frac{1}{(2s+1)}.$$

$$[11.82] \quad \mu_k^{(1)\{P_k^{(0,\beta)}(\tau,\gamma)\}} = \frac{1}{\gamma^2} \sum_{s=0}^k \binom{k}{s} \binom{k+s+\beta}{s} (-1)^s \frac{1}{(2s+1)^2}.$$

$$[11.83] \quad \mu_k^{(2)\{P_k^{(0,\beta)}(\tau,\gamma)\}} = \frac{2}{\gamma^3} \sum_{s=0}^k \binom{k}{s} \binom{k+s+\beta}{s} (-1)^s \frac{1}{(2s+1)^3}.$$

$$[11.84] \quad \mu_k^{(3)\{P_k^{(0,\beta)}(\tau,\gamma)\}} = \frac{6}{\gamma^4} \sum_{s=0}^k \binom{k}{s} \binom{k+s+\beta}{s} (-1)^s \frac{1}{(2s+1)^4}.$$

$$[11.85] \quad \mu_k^{(n)\{P_k^{(0,\beta)}(\tau,\gamma)\}} = \frac{n!}{\gamma^{n+1}} \sum_{s=0}^k \binom{k}{s} \binom{k+s+\beta}{s} (-1)^s \frac{1}{(2s+1)^{n+1}}.$$

### 11.3 Длительности ортогональных функций в частотной области

$$[11.86] \quad \Delta\omega_k^{(2)\{\text{Re}W_k^{\{L_k^{(1)}(\tau,\gamma)\}}(j\omega)\}} = \frac{\pi\gamma(k+1)}{4((k+1) \bmod 2)},$$

$$k = 0, 2, 4, \dots, 2n, \quad n \in \mathbb{N}_0.$$

$$[11.87] \quad \Delta\omega_k^{(4)\{\text{Re}W_k^{\{L_k^{(1)}(\tau,\gamma)\}}(j\omega)\}} = \frac{\pi\gamma(k+1)}{8((k+1) \bmod 2)^2}, \quad k = 0, 2, 4, \dots, 2n, \quad n \in \mathbb{N}_0.$$

$$[11.88] \quad \Delta\omega_k^{(2)\{\text{Re}W_k^{\{L_k^{(2)}(\tau,\gamma)\}}(j\omega)\}} = \frac{\pi\gamma(k+1)(k+2)}{8((k+2) \bmod 2)}.$$

$$[11.89] \quad \Delta\omega_k^{(4)\{\text{Re}W_k^{\{L_k^{(2)}(\tau,\gamma)\}}(j\omega)\}} = \frac{\pi\gamma(2k+3)(k+1)(k+2)}{4((k+2) \bmod 2)^2}.$$

$$[11.90] \quad \Delta\omega_k^{(2)\{\text{Re}W_k^{\{P_k^{(-1/2,0)}(\tau,\gamma)\}}(j\omega)\}} = \frac{\pi\gamma(-1)^k(4k+1)}{4}, \quad k = 0, 2, 4, \dots, 2n, \quad n \in \mathbb{N}_0.$$

$$[11.91] \quad \Delta\omega_k^{(4)\{\text{Re}W_k^{\{P_k^{(-1/2,0)}(\tau,\gamma)\}}(j\omega)\}} = \frac{\pi\gamma(4k+1)}{8}.$$

$$[11.92] \quad \Delta\omega_k^{(2)\{\text{Re}W_k^{\{Leg_k(\tau,\gamma)\}}(j\omega)\}} = \frac{\pi\gamma(-1)^k(2k+1)}{2},$$

$$k = 0, 2, 4, \dots, 2n, \quad n \in \mathbb{N}_0.$$

$$[11.93] \quad \Delta\omega_k^{(4)\{\text{Re}W_k^{\{Leg_k(\tau,\gamma)\}}(j\omega)\}} = \frac{\pi\gamma(2k+1)}{4}.$$

$$[11.94] \quad \Delta\omega_k^{(2)\{\text{Re}W_k^{\{P_k^{(1/2,0)}(\tau,\gamma)\}}(j\omega)\}} = \frac{\pi\gamma(-1)^k(4k+3)}{4}, \quad k = 0, 2, 4, \dots, 2n, \quad n \in \mathbb{N}_0.$$

$$[11.95] \quad \Delta\omega_k^{(4)\{\text{Re}W_k^{\{P_k^{(1/2,0)}(\tau,\gamma)\}}(j\omega)\}} = \frac{\pi\gamma(4k+3)}{8}.$$

$$[11.96] \quad \Delta\omega_k^{(2)\{\text{Re}W_k^{\{P_k^{(1,0)}(\tau,\gamma)\}}(j\omega)\}} = \frac{\pi\gamma(-1)^k(k+1)}{2},$$

$$k = 0, 2, 4, \dots, 2n, \quad n \in \mathbb{N}_0.$$

$$[11.97] \quad \Delta\omega_k^{(4)\{\text{Re}W_k^{\{P_k^{(1,0)}(\tau,\gamma)\}}(j\omega)\}} = \frac{\pi\gamma(k+1)}{4}.$$

$$[11.98] \quad \Delta\omega_k^{(2)\{\text{Re}W_k^{\{P_k^{(2,0)}(\tau,\gamma)\}}(j\omega)\}} = \frac{\pi\gamma(-1)^k(2k+3)}{2}, \quad k = 0, 2, 4, \dots, 2n, \quad n \in \mathbb{N}_0.$$

$$[11.99] \Delta\omega_k^{(4)\{ReW_k^{P_k^{(2,0)}(\tau,\gamma)}\}(j\omega)} = \frac{\pi\gamma(2k+3)}{4}.$$

$$[11.100] \Delta\omega_k^{(2)\{ReW_k^{P_k^{(0,1)}(\tau,\gamma)}\}(j\omega)} = \\ = \frac{\pi\gamma(k+1)^2}{2((k+1) \bmod 2)}, k=0, 2, 4, \dots, 2n, \quad n \in \mathbb{N}_0.$$

$$[11.101] \Delta\omega_k^{(4)\{ReW_k^{P_k^{(0,1)}(\tau,\gamma)}\}(j\omega)} = \\ = \frac{\pi\gamma(k+1)^2}{4((k+1) \bmod 2)^2}, k=0, 2, 4, \dots, 2n, \quad n \in \mathbb{N}_0.$$

$$[11.102] \Delta\omega_k^{(2)\{ReW_k^{P_k^{(0,2)}(\tau,\gamma)}\}(j\omega)} = \\ = \frac{\pi\gamma(-1)^k(k+1)^2(k+2)^2}{8((k+2) \operatorname{div} 2)^2}, \\ k=0, 2, 4, \dots, 2n, \quad n \in \mathbb{N}_0.$$

$$[11.103] \Delta\omega_k^{(4)\{ReW_k^{P_k^{(0,2)}(\tau,\gamma)}\}(j\omega)} = \\ = \frac{\pi\gamma((k+1)(k+2)+1)(k+1)^2(k+2)^2}{48((k+2) \operatorname{div} 2)^4}, \\ k=0, 2, 4, \dots, 2n, \quad n \in \mathbb{N}_0.$$

#### 11.4 Моментные характеристики ортогональных функций в частотной области

$$[11.104] \mu_k^{(0)\{W_k^{L_k(\tau,\gamma)}\}(j\omega)} = \frac{\pi}{2}.$$

$$[11.105] \mu_k^{(1)\{W_k^{L_k(\tau,\gamma)}\}(j\omega)} = \frac{\pi\gamma(2k+1)}{4}.$$

$$[11.106] \mu_k^{(2)\{W_k^{L_k(\tau,\gamma)}\}(j\omega)} = \frac{\pi\gamma^2((2k+1)^2+1)}{16}.$$

$$[11.107] \mu_k^{(3)\{W_k^{L_k(\tau,\gamma)}\}(j\omega)} = \\ = \frac{\pi\gamma^3((2k+1)^3+5(2k+1))}{96}.$$

$$[11.108] \mu_k^{(n)\{W_k^{L_k(\tau,\gamma)}\}(j\omega)} = \frac{\pi\gamma^n}{2} \sum_{j=0}^n \binom{n}{j} 2^{-j} \times \\ \times \begin{cases} \binom{k}{n-j}, & \text{если } k-n+j \geq 0; \\ 0, & \text{иначе.} \end{cases}$$

$$[11.109] \mu_k^{(0)\{W_k^{L_k^{(1)}(\tau,\gamma)}\}(j\omega)} = \frac{\pi(k+1)}{2}.$$

$$[11.110] \mu_k^{(1)\{W_k^{L_k^{(1)}(\tau,\gamma)}\}(j\omega)} = \frac{\pi\gamma(k+1)^2}{4}.$$

$$[11.111] \mu_k^{(2)\{W_k^{L_k^{(1)}(\tau,\gamma)}\}(j\omega)} = \\ = \frac{\pi\gamma^2(k+1)(2k^2+4k+3)}{24}.$$

$$[11.112] \mu_k^{(3)\{W_k^{L_k^{(1)}(\tau,\gamma)}\}(j\omega)} = \\ = \frac{\pi\gamma^3(k+1)^2(k^2+2k+3)}{48}.$$

$$[11.113] \mu_k^{(n)\{W_k^{L_k^{(1)}(\tau,\gamma)}\}(j\omega)} = \frac{\pi\gamma^n}{2} \sum_{j=0}^n \binom{n}{j} 2^{-j} \times \\ \times \begin{cases} \binom{k+1}{n-j+1}, & \text{если } k-n+j \geq 0; \\ 0, & \text{иначе.} \end{cases}$$

$$[11.114] \mu_k^{(0)\{W_k^{L_k^{(2)}(\tau,\gamma)}\}(j\omega)} = \frac{\pi(k+1)(k+2)}{4}.$$

$$[11.115] \mu_k^{(1)\{W_k^{L_k^{(2)}(\tau,\gamma)}\}(j\omega)} = \\ = \frac{\pi\gamma(k+1)(k+2)(2k+3)}{24}.$$

$$[11.116] \mu_k^{(2)\{W_k^{L_k^{(2)}(\tau,\gamma)}\}(j\omega)} = \\ = \frac{\pi\gamma^2(k+1)(k+2)(k^2+3k+3)}{48}.$$

$$[11.117] \mu_k^{(3)\{W_k^{L_k^{(2)}(\tau,\gamma)}\}(j\omega)} = \\ = \frac{\pi\gamma^3(k+1)(k+2)(2k+3)(k^2+3k+5)}{480}.$$

$$[11.118] \mu_k^{(n)\{W_k^{L_k^{(2)}(\tau,\gamma)}\}(j\omega)} = \frac{\pi\gamma^n}{2} \sum_{j=0}^n \binom{n}{j} 2^{-j} \times \\ \times \begin{cases} \binom{k+2}{n-j+2}, & \text{если } k-n+j \geq 0; \\ 0, & \text{иначе.} \end{cases}$$

$$[11.119] \mu_k^{(0)\{W_k^{L_k^{(\alpha)}(\tau,\gamma)}\}(j\omega)} = \frac{\pi}{4} \binom{k+\alpha}{k}.$$

$$[11.120] \mu_k^{(1)\{W_k^{L_k^{(\alpha)}(\tau,\gamma)}\}(j\omega)} = \frac{\pi\gamma}{2} \sum_{j=0}^1 \binom{1}{j} 2^{-j} \times \\ \times \begin{cases} \binom{k+2}{3-j}, & \text{если } k-1+j \geq 0; \\ 0, & \text{иначе.} \end{cases}$$

$$[11.121] \mu_k^{(2)\{W_k^{L_k^{(\alpha)}(\tau,\gamma)}\}(j\omega)} = \frac{\pi\gamma^2}{2} \sum_{j=0}^2 \binom{2}{j} 2^{-j} \times \\ \times \begin{cases} \binom{k+2}{4-j}, & \text{если } k-2+j \geq 0; \\ 0, & \text{иначе.} \end{cases}$$



$$[11.122] \quad \mu_k^{(3)\{W_k^{L_k^{(\alpha)}(\tau, \gamma)}\}}(j\omega) = \frac{\pi\gamma^3}{2} \sum_{j=0}^3 \binom{3}{j} 2^{-j} \times \\ \times \begin{cases} \binom{k+2}{5-j}, & \text{если } k-3+j \geq 0; \\ 0, & \text{иначе.} \end{cases}$$

$$[11.123] \quad \mu_k^{(n)\{W_k^{L_k^{(\alpha)}(\tau, \gamma)}\}}(j\omega) = \frac{\pi\gamma^n}{2} \sum_{j=0}^n \binom{n}{j} 2^{-j} \times \\ \times \begin{cases} \binom{k+2}{n-j+2}, & \text{если } k-n+j \geq 0; \\ 0, & \text{иначе.} \end{cases}$$

$$[11.124] \quad \mu_k^{(0)\{W_k^{P_k^{(-1/2,0)}(\tau, \gamma)}\}}(j\omega) = \frac{\pi}{2} (-1)^k.$$

$$[11.125] \quad \mu_k^{(1)\{W_k^{P_k^{(-1/2,0)}(\tau, \gamma)}\}}(j\omega) = \\ = \frac{\pi\gamma}{4} \sum_{s=0}^k \binom{k}{s} \binom{k+s-1/2}{s-1/2} (-1)^s (4s+1).$$

$$[11.126] \quad \mu_k^{(2)\{W_k^{P_k^{(-1/2,0)}(\tau, \gamma)}\}}(j\omega) = \\ = \frac{\pi\gamma^2}{8} \sum_{s=0}^k \binom{k}{s} \binom{k+s-1/2}{s-1/2} (-1)^s (4s+1)^2.$$

$$[11.127] \quad \mu_k^{(3)\{W_k^{P_k^{(-1/2,0)}(\tau, \gamma)}\}}(j\omega) = \\ = \frac{\pi\gamma^3}{16} \sum_{s=0}^k \binom{k}{s} \binom{k+s-1/2}{s-1/2} (-1)^s (4s+1)^3.$$

$$[11.128] \quad \mu_k^{(n)\{W_k^{P_k^{(-1/2,0)}(\tau, \gamma)}\}}(j\omega) = \\ = \frac{\pi(\gamma/2)^n}{2} \sum_{s=0}^k \binom{k}{s} \binom{k+s-1/2}{s-1/2} (-1)^s (4s+1)^n.$$

$$[11.129] \quad \mu_k^{(0)\{W_k^{Leg_k(\tau, \gamma)}\}}(j\omega) = \frac{\pi}{2} (-1)^k.$$

$$[11.130] \quad \mu_k^{(1)\{W_k^{Leg_k(\tau, \gamma)}\}}(j\omega) = \\ = \frac{\pi\gamma}{2} \sum_{s=0}^k \binom{k}{s} \binom{k+s}{s} (-1)^s (2s+1).$$

$$[11.131] \quad \mu_k^{(2)\{W_k^{Leg_k(\tau, \gamma)}\}}(j\omega) = \\ = \frac{\pi\gamma^2}{2} \sum_{s=0}^k \binom{k}{s} \binom{k+s}{s} (-1)^s (2s+1)^2.$$

$$[11.132] \quad \mu_k^{(3)\{W_k^{Leg_k(\tau, \gamma)}\}}(j\omega) = \\ = \frac{\pi\gamma^3}{2} \sum_{s=0}^k \binom{k}{s} \binom{k+s}{s} (-1)^s (2s+1)^3.$$

$$[11.133] \quad \mu_k^{(n)\{W_k^{Leg_k(\tau, \gamma)}\}}(j\omega) = \\ = \frac{\pi\gamma^n}{2} \sum_{s=0}^k \binom{k}{s} \binom{k+s}{s} (-1)^s (2s+1)^n.$$

$$[11.134] \quad \mu_k^{(0)\{W_k^{P_k^{(1/2,0)}(\tau, \gamma)}\}}(j\omega) = \frac{\pi}{2} (-1)^k.$$

$$[11.135] \quad \mu_k^{(1)\{W_k^{P_k^{(1/2,0)}(\tau, \gamma)}\}}(j\omega) = \\ = \frac{\pi\gamma}{4} \sum_{s=0}^k \binom{k}{s} \binom{k+s+1/2}{s+1/2} (-1)^s (4s+3).$$

$$[11.136] \quad \mu_k^{(2)\{W_k^{P_k^{(1/2,0)}(\tau, \gamma)}\}}(j\omega) = \\ = \frac{\pi\gamma^2}{8} \sum_{s=0}^k \binom{k}{s} \binom{k+s+1/2}{s+1/2} (-1)^s (4s+3)^2.$$

$$[11.137] \quad \mu_k^{(3)\{W_k^{P_k^{(1/2,0)}(\tau, \gamma)}\}}(j\omega) = \\ = \frac{\pi\gamma^3}{16} \sum_{s=0}^k \binom{k}{s} \binom{k+s+1/2}{s+1/2} (-1)^s (4s+3)^3.$$

$$[11.138] \quad \mu_k^{(n)\{W_k^{P_k^{(1/2,0)}(\tau, \gamma)}\}}(j\omega) = \\ = \frac{\pi(\gamma/2)^n}{2} \sum_{s=0}^k \binom{k}{s} \binom{k+s+1/2}{s+1/2} (-1)^s (4s+3)^n.$$

$$[11.139] \quad \mu_k^{(0)\{W_k^{P_k^{(1,0)}(\tau, \gamma)}\}}(j\omega) = \frac{\pi}{2} (-1)^k.$$

$$[11.140] \quad \mu_k^{(1)\{W_k^{P_k^{(1,0)}(\tau, \gamma)}\}}(j\omega) = \\ = \frac{\pi\gamma}{2} \sum_{s=0}^k \binom{k}{s} \binom{k+s+1}{s+1} (-1)^s (s+1).$$

$$[11.141] \quad \mu_k^{(2)\{W_k^{P_k^{(1,0)}(\tau, \gamma)}\}}(j\omega) = \\ = \frac{\pi\gamma^2}{2} \sum_{s=0}^k \binom{k}{s} \binom{k+s+1}{s+1} (-1)^s (s+1)^2.$$

$$[11.142] \quad \mu_k^{(3)\{W_k^{P_k^{(1,0)}(\tau, \gamma)}\}}(j\omega) = \\ = \frac{\pi\gamma^3}{2} \sum_{s=0}^k \binom{k}{s} \binom{k+s+1}{s+1} (-1)^s (s+1)^3.$$

$$\begin{aligned}
 [11.143] \quad \mu_k^{(n)\{W_k^{P_k^{(1,0)}(\tau,\gamma)}\}}(j\omega) &= \\
 &= \frac{\pi\gamma^n}{2} \sum_{s=0}^k \binom{k}{s} \binom{k+s+1}{s+1} (-1)^s (s+1)^n.
 \end{aligned}$$

$$[11.144] \quad \mu_k^{(0)\{W_k^{P_k^{(2,0)}(\tau,\gamma)}\}}(j\omega) = \frac{\pi}{2} (-1)^k.$$

$$\begin{aligned}
 [11.145] \quad \mu_k^{(1)\{W_k^{P_k^{(2,0)}(\tau,\gamma)}\}}(j\omega) &= \\
 &= \frac{\pi\gamma}{2} \sum_{s=0}^k \binom{k}{s} \binom{k+s+2}{s+2} (-1)^s (2s+3).
 \end{aligned}$$

$$\begin{aligned}
 [11.146] \quad \mu_k^{(2)\{W_k^{P_k^{(2,0)}(\tau,\gamma)}\}}(j\omega) &= \\
 &= \frac{\pi\gamma^2}{2} \sum_{s=0}^k \binom{k}{s} \binom{k+s+2}{s+2} (-1)^s (2s+3)^2.
 \end{aligned}$$

$$\begin{aligned}
 [11.147] \quad \mu_k^{(3)\{W_k^{P_k^{(2,0)}(\tau,\gamma)}\}}(j\omega) &= \\
 &= \frac{\pi\gamma^3}{2} \sum_{s=0}^k \binom{k}{s} \binom{k+s+2}{s+2} (-1)^s (2s+3)^3.
 \end{aligned}$$

$$\begin{aligned}
 [11.148] \quad \mu_k^{(n)\{W_k^{P_k^{(2,0)}(\tau,\gamma)}\}}(j\omega) &= \\
 &= \frac{\pi\gamma^n}{2} \sum_{s=0}^k \binom{k}{s} \binom{k+s+2}{s+2} (-1)^s (2s+3)^n.
 \end{aligned}$$

$$[11.149] \quad \mu_k^{(0)\{W_k^{P_k^{(\alpha,0)}(\tau,\gamma)}\}}(j\omega) = \frac{\pi}{2} (-1)^k.$$

$$\begin{aligned}
 [11.150] \quad \mu_k^{(1)\{W_k^{P_k^{(\alpha,0)}(\tau,\gamma)}\}}(j\omega) &= \\
 &= \frac{\pi c\gamma}{2} \sum_{s=0}^k \binom{k}{s} \binom{k+s+\alpha}{s+\alpha} (-1)^s (2s+\alpha+1).
 \end{aligned}$$

$$\begin{aligned}
 [11.151] \quad \mu_k^{(2)\{W_k^{P_k^{(\alpha,0)}(\tau,\gamma)}\}}(j\omega) &= \\
 &= \frac{\pi c^2\gamma^2}{2} \sum_{s=0}^k \binom{k}{s} \binom{k+s+\alpha}{s+\alpha} (-1)^s (2s+\alpha+1)^2.
 \end{aligned}$$

$$\begin{aligned}
 [11.152] \quad \mu_k^{(3)\{W_k^{P_k^{(\alpha,0)}(\tau,\gamma)}\}}(j\omega) &= \\
 &= \frac{\pi c^3\gamma^3}{2} \sum_{s=0}^k \binom{k}{s} \binom{k+s+\alpha}{s+\alpha} (-1)^s (2s+\alpha+1)^3.
 \end{aligned}$$

$$\begin{aligned}
 [11.153] \quad \mu_k^{(n)\{W_k^{P_k^{(\alpha,0)}(\tau,\gamma)}\}}(j\omega) &= \\
 &= \frac{\pi c^n\gamma^n}{2} \sum_{s=0}^k \binom{k}{s} \binom{k+s+\alpha}{s+\alpha} (-1)^s (2s+\alpha+1)^n.
 \end{aligned}$$

$$[11.154] \quad \mu_k^{(0)\{W_k^{P_k^{(0,1)}(\tau,\gamma)}\}}(j\omega) = \frac{\pi}{2} (-1)^k.$$

$$\begin{aligned}
 [11.155] \quad \mu_k^{(1)\{W_k^{P_k^{(0,1)}(\tau,\gamma)}\}}(j\omega) &= \\
 &= \frac{\pi\gamma}{2} \sum_{s=0}^k \binom{k}{s} \binom{k+s+1}{s} (-1)^s (2s+1).
 \end{aligned}$$

$$\begin{aligned}
 [11.156] \quad \mu_k^{(2)\{W_k^{P_k^{(0,1)}(\tau,\gamma)}\}}(j\omega) &= \\
 &= \frac{\pi\gamma^2}{2} \sum_{s=0}^k \binom{k}{s} \binom{k+s+1}{s} (-1)^s (2s+1)^2.
 \end{aligned}$$

$$\begin{aligned}
 [11.157] \quad \mu_k^{(3)\{W_k^{P_k^{(0,1)}(\tau,\gamma)}\}}(j\omega) &= \\
 &= \frac{\pi\gamma^3}{2} \sum_{s=0}^k \binom{k}{s} \binom{k+s+1}{s} (-1)^s (2s+1)^3.
 \end{aligned}$$

$$\begin{aligned}
 [11.158] \quad \mu_k^{(n)\{W_k^{P_k^{(0,1)}(\tau,\gamma)}\}}(j\omega) &= \\
 &= \frac{\pi\gamma^n}{2} \sum_{s=0}^k \binom{k}{s} \binom{k+s+1}{s} (-1)^s (2s+1)^n.
 \end{aligned}$$

$$[11.159] \quad \mu_k^{(0)\{W_k^{P_k^{(0,1)}(\tau,\gamma)}\}}(j\omega) = \frac{\pi}{2} (-1)^k.$$

$$\begin{aligned}
 [11.160] \quad \mu_k^{(1)\{W_k^{P_k^{(0,2)}(\tau,\gamma)}\}}(j\omega) &= \\
 &= \frac{\pi\gamma}{2} \sum_{s=0}^k \binom{k}{s} \binom{k+s+2}{s} (-1)^s (2s+1).
 \end{aligned}$$

$$\begin{aligned}
 [11.161] \quad \mu_k^{(2)\{W_k^{P_k^{(0,2)}(\tau,\gamma)}\}}(j\omega) &= \\
 &= \frac{\pi\gamma^2}{2} \sum_{s=0}^k \binom{k}{s} \binom{k+s+2}{s} (-1)^s (2s+1)^2.
 \end{aligned}$$

$$\begin{aligned}
 [11.162] \quad \mu_k^{(3)\{W_k^{P_k^{(0,2)}(\tau,\gamma)}\}}(j\omega) &= \\
 &= \frac{\pi\gamma^3}{2} \sum_{s=0}^k \binom{k}{s} \binom{k+s+2}{s} (-1)^s (2s+1)^3.
 \end{aligned}$$

$$\begin{aligned}
 [11.163] \quad \mu_k^{(n)\{W_k^{P_k^{(0,2)}(\tau,\gamma)}\}}(j\omega) &= \\
 &= \frac{\pi\gamma^n}{2} \sum_{s=0}^k \binom{k}{s} \binom{k+s+2}{s} (-1)^s (2s+1)^n.
 \end{aligned}$$

$$[11.164] \quad \mu_k^{(0)\{W_k^{P_k^{(0,\beta)}(\tau,\gamma)}\}}(j\omega) = \frac{\pi}{2} (-1)^k.$$

$$\begin{aligned}
 [11.165] \quad \mu_k^{(1)\{W_k^{(0,\beta)}(\tau,\gamma)\}(j\omega)} &= \\
 &= \frac{\pi c \gamma}{2} \sum_{s=0}^k \binom{k}{s} \binom{k+s+\beta}{s} (-1)^s (2s+1).
 \end{aligned}$$

$$\begin{aligned}
 [11.166] \quad \mu_k^{(2)\{W_k^{(0,\beta)}(\tau,\gamma)\}(j\omega)} &= \\
 &= \frac{\pi c^2 \gamma^2}{2} \sum_{s=0}^k \binom{k}{s} \binom{k+s+\beta}{s} (-1)^s (2s+1)^2.
 \end{aligned}$$

$$\begin{aligned}
 [11.167] \quad \mu_k^{(3)\{W_k^{(0,\beta)}(\tau,\gamma)\}(j\omega)} &= \\
 &= \frac{\pi c^3 \gamma^3}{2} \sum_{s=0}^k \binom{k}{s} \binom{k+s+\beta}{s} (-1)^s (2s+1)^3.
 \end{aligned}$$

$$\begin{aligned}
 [11.168] \quad \mu_k^{(n)\{W_k^{(0,\beta)}(\tau,\gamma)\}(j\omega)} &= \\
 &= \frac{\pi c^n \gamma^n}{2} \sum_{s=0}^k \binom{k}{s} \binom{k+s+\beta}{s} (-1)^s (2s+1)^n.
 \end{aligned}$$



## Глава 12

# Соотношения неопределенности

### Определение.

На основе понятий длительности ортогональных функций во временной и частотной областях, приведенных в Главе 11, получены соотношения неопределенности.

$$[12.1] \int_0^{\infty} (\psi_k(\tau, \gamma))^2 d\tau = \frac{2}{\pi} \int_0^{\infty} (\operatorname{Re} W_k^{\{\psi_k(\tau, \gamma)\}}(j\omega))^2 d\omega.$$

$$[12.2] \tau_k^{(2)\{\psi_k(\tau, \gamma)\}} \Delta\omega_k^{(2)\{\operatorname{Re} W_k^{\{\psi_k(\tau, \gamma)\}}(j\omega)\}} = \frac{\pi}{2}.$$

$$[12.3] \tau_k^{(4)\{\psi_k(\tau, \gamma)\}} \frac{(\Delta\omega_k^{(2)\{\operatorname{Re} W_k^{\{\psi_k(\tau, \gamma)\}}(j\omega)\}})^2}{\Delta\omega_k^{(4)\{\operatorname{Re} W_k^{\{\psi_k(\tau, \gamma)\}}(j\omega)\}}} = \frac{\pi}{2}.$$

$$[12.4] \int_0^{\infty} \tau^n \psi_k(\tau, \gamma) d\tau = j^n \frac{d^n W_k^{\{\psi_k(\tau, \gamma)\}}(j\omega)}{d\omega^n} \Big|_{j\omega=0}.$$

$$[12.5] \int_0^{\infty} \omega^n W_k^{\{\psi_k(\tau, \gamma)\}}(j\omega) d\omega = \frac{\pi}{2} (-1)^n \frac{\partial^n \psi_k(\tau, \gamma)}{\partial \tau^n} \Big|_{\tau=0}.$$



## СПИСОК ИСПОЛЬЗОВАННЫХ ИСТОЧНИКОВ

- 1 *Ван дер Поль, Б.* Операционное исчисление на основе двустороннего преобразования Лапласа: пер. с англ./Б. Ван дер Поль, Х. Времмер.— М.: издательство иностранной литературы, 1952.—506 с.
- 2 *Геронимус, Я.Л.* Теория ортогональных многочленов. Обзор достижений отечественной математики/Я.Л. Геронимус.— М.,Л.: Государственной издательство технико - теоретической литературы, 1950.—164 с.
- 3 *Дедус, Ф.Ф.* Обобщенный спектрально - аналитический метод обработки информационных массивов. Задачи анализа изображений и распознавания образов/Под редакцией Ф.Ф. Дедуса/Ф.Ф. Дедус, С.А. Махортых, М.Н. Устинин, А.Ф. Дедус.— М.: Машиностроение, 1999.—357 с.
- 4 *Джексон, Д.* Ряды Фурье и ортогональные полиномы: пер. с англ./Д. Джексон.— М.,Л.: Главное издательство иностранной литературы, 1948.—260 с.
- 5 *Куликовских, И.М.* Построение моделей корреляционно-спектральных характеристик методом аналитических разложений: диссертация ... кандидата технических наук : 05.13.18 / Куликовских Илона Марковна.— Самара, 2011.— 133 с.
- 6 *Прохоров, С.А.* Аппроксимативный анализ случайных процессов/С.А. Прохоров.—2-е изд., перераб. и доп.— Самара: СНЦ РАН, 2001.—380 с.
- 7 *Прохоров, С.А.* Методы оценки коэффициентов разложения ортогональных рядов/С.А. Прохоров, И.М. Куликовских// Идентификация, измерение характеристик и имитация случайных сигналов (состояние, перспективы развития) (ИИИ'2009): сборник материалов международной конференции. —Новосибирск: НГТУ, 2009. — С. 168-171.
- 8 *Прохоров, С.А.* О некоторых свойствах ортогональности/С.А. Прохоров, И.М. Куликовских// Информатика, моделирование, автоматизация проектирования (ИМАП-2009): сборник научных трудов Российской школы-семинара аспирантов, студентов и молодых ученых. —Ульяновск, 2009. — С. 195-197.
- 9 *Прохоров, С.А.* Ортогональные модели корреляционно - спектральных характеристик случайных процессов. Лабораторный практикум/С.А. Прохоров, И.М. Куликовских.— Самара: СНЦ РАН, 2008.—301 с.
- 10 *Прохоров, С.А.* Погрешность оценки спектра по параметрам аппроксимирующего выражения корреляционной функции/С.А. Прохоров, И.М. Куликов-

- ских//Математическое моделирование и краевые задачи: труды пятой Всероссийской научной конференции с международным участием. – Ч.4.–Самара, 2008. – С. 116-120.
- 11 *Прохоров, С.А.* Применение метода ортогональных разложений для выявления зависимостей между характеристиками ортогональных базисов/ С.А. Прохоров, И.М. Куликовских//Аналитические и численные методы моделирования естественнонаучных и социальных проблем: сборник статей IV Международной научно - технической конференции.—Пенза: Приволжский Дом знаний, 2009. – С. 81-83.
  - 12 *Сато, Ю.* Без паники! Цифровая обработка сигналов: пер. с яп. Селиной Т.Г./Ю. Сато.— М.: Додэка-XXI, 2010.—176 с.
  - 13 *Суэтин, П.К.* Классические ортогональные многочлены: в 2-х томах/П.К. Суэтин.— М.: Наука, 1976.—Т. 1. —328 с.
  - 14 *Тихонов, В.И.* Выбросы траекторий случайных процессов/В.И. Тихонов, В.И. Хименко.— М.: Наука, 1987.—304 с.
  - 15 *Ismail, Mourad E.H.* Structure relations for orthogonal polynomials/Mourad E.H. Ismail//Pacific journal of mathematics.—2009.— № 2 (240).—pp. 309-319.
  - 16 *Masjed-Jamei, M.* Some new classes of orthogonal polynomials and special functions: a symmetric generalization of Sturm-Liouville problems and its consequences: Ph.D thesis supervised by Professor Wolfram KOEPF/M. Masjed-Jamei.—Germany, University of Kassel, Department of Mathematics, 2006.—120 p.
  - 17 *Olver, Frank W.J.* NIST Handbook of Mathematical functions/Frank W.J. Olver, Daniel W. Lozier, Ronald F. Boisvert, Charles W. Clark.—Cambridge University Press, National Institute of Standards and Technology, 2010.—967 p.
  - 18 *Szego, G.* Orthogonal polynomials/ G. Szego.—Rhode Island: American Mathematical Society Providence, 1939.—431 p.
  - 19 *Totik, V.* Orthogonal polynomials/V. Totik//Surveys in Approximation Theory.—2005.— № 1 (2005).—pp. 70-125.



ДЛЯ ЗАМЕТОК

ДЛЯ ЗАМЕТОК